

## CONTENT

INDEX	PAGE
<b>DRILL BITS</b>	<b>1-24</b>
Parallel shank drill, Jobber Series, Metric	1
Jobber length drill, Ansi	2
Parallel shank drill, Stub series, Metric	2-3
Screw machine Length Drill, Ansi	3-4
Parallel shank twist drill, Long series, Metric	4
Taper length drill, Ansi	5
Print circuit board carbide drill	6
Double end drill	6
Parallel shank twist drill, Extra long, Metric	6
Aircraft extension drill, Ansi	7
Long boy drill, Ansi	7
HSS drill blank, Metric sizes	8
HSS drill blank, Inch sizes	9
HSS annular hole cutter	9
Taper shank twist drill	10-11
Taper shank twist drill, Long series	12
Taper shank lengthened twist drill	13
1/4" reduced shank twist drill	14
1/2" reduced shank twist drill	14
Silver & deming drill	14
Solid carbide drill	15
Carbide tipped drill	16
Taper shank carbide tipped drill	17
Straight shank core drill	17
Taper shank core drill	18
Subland drill	19
Center drill	20
3-flute countersinks	21
1-flute countersinks	21
5-flute countersinks	21
6-flute countersinks	21
Countersinks & Deburring tools	21
Cap screw counterbore	22
6-flute countersinks	22
Steps drill,	22
Steps drill set	22
Drill sets	23-24
<b>MILLING CUTTER</b>	<b>25-42</b>
2-flute end mill, Metric	25
3-flute end mill, Metric	25
4-flute end mill, metric	26
2-flute ball nose end mill, metric	26
4-flute ball nose end mill, metric	26
2-flute end mill, Taper shank, metric	27
Taper shank end mill, Metric	27
Rough end mill, Straight shank, Metric	27-28
Rough end mill. Taper shank, Metric	28
Solid carbide 2-flute end mill, metric	28
Solid carbide 4-flute end mill, Metric	28
Carbide tipped tipped end mill,	29
4-flute end mill, ANSI	29
2-flute end mill, ANSI	30
2-flute long length end mill, ANSI	30
2-flute extended shank end mill, ANSI	31
4-flute double end mill, ANSI	31
2-flute double end mill, ANSI	31
3/16" shank double end mill, ANSI	31
ball nose end mill, ANSI	32
Rough end mill 4-flute, ANSI	32

INDEX	PAGE
<b>MILLING CUTTER</b>	<b>25-42</b>
Solid carbide end mill	33
carbide tipped end mill	33
T slot cutter	34
Woodruff keyseat cutter, ANSI	34
Woodruff keyseat cutter, Metric	35
Dovetail cutter	35
Single angle cutter with shank, ANSI	35
Plain milling cutter,	36
Shell end mill	36
Rough shell end mill	36
Side & face cutter, Straight teeth	37
Side & face cutter, Staggered teeth	37
Convex cutter	38
concave cutter	38
Single angle milling cutter	39
Angle milling cutter	39
double angle milling cutter	39
Metal slitting saw, ANSI	40
Metal slitting saw, fine teeth, Metric	40-41
Metal slitting saw, coarse teeth, Metric	41
Screw slotting saws, Metric	41
Screw slotting saws, INCH	42
Jewellers saw	42
<b>REAMERS</b>	<b>43-52</b>
Hand reamer, Metric	43
Machine reamers, metric	43
Chuck reamer, ANSI	44
Hand reamer, ANSI	45
carbide tipped reamers	45
Expansion hand reamer, Metric	45
Expansion hand reamer, ANSI	46
Adjustable reamer	46
Morse taper reamer	47
NPT taper pipe reamer	47
Taper pin reamer, ANSI	47
1:50 Taper pin reamer	47
Taper shank machine reamer, metric	48
Taper shank chuck reamer, ANSI	48
Carbide tipped chuck reamer, ANSI	48
Carbide tipped machine reamer, Metric	49
Bridge reamer	49
Shell reamer	50
Shell reamer arbor	50
Hand reamer, GOST	51
Machine reamers, GOST	51
Morse taper reamer, GOST	52
1:30 taper pin reamer, GOST	52
1:50 tap pin reamer, GOST	52
Adjustable hand reamer, GOST	52
<b>TAPS &amp; DIES</b>	<b>53-69</b>
Hand taps, 3pcs/set, DIN352	53
Hand taps, 2pcs/set, DIN2181	53
Machine taps, DIN371	54
Spiral flute taps, DIN371	54
Spiral point taps, DIN371	54
Machine taps, DIN376	54
Spiral flute taps, DIN376	54
Spiral point taps, DIN376	54
Nut taps, DIN357	55





## CONTENT

INDEX	PAGE
<b>TAPS &amp; DIES</b>	<b>53-69</b>
BSW reamer, DIN351	55
Pipe taps, DIN6156	55
Pipe taps, DIN6157	55
Hand & machine taps, ISO529	56
BSW machine taps, ISO529	56
Hand taps, ANSI	57
Spiral point taps, ANSI	57
Spiral flute taps, ANSI	57
Pulley taps, ANSI	58
Nut taps, ANSI	58
Long reach extension taps	58
Thread forming taps	59
Single pass ACME taps	59
Combined drill & taps	59
Taper pipe taps (NPT/NPTF), ANSI	59
Interrupted thread NPT taps, ANSI	60
Straight pipe (NPS) taps, ANSI	60
Special thread taps	60
Hand & machine taps, GOST	61
Hand taps, GOST	61
Pipe taps, GOST	62
Straight pipe taps, GOST	62
Round dies, GOST	62
Pipe dies, GOST	62
Round dies, DIN223	63
BSW round dies, DIN223	63
Straight pipe dies, DIN5158	64
Taper pipe dies, DIN5159	64
Hexagon dies, Metric	64
Adjustable split dies, ANSI	64-65
Adjustable round pipe dies, ANSI	65
Special adjustable round dies, ANSI	65
Hexagon rethread dies, ANSI	65-66
Tap wrench	66
Dies stock	66-67
T handle tap wrench	67
T handle racket wrench	67
Screw extractor & set	67
Tap & dies sets	68-69
<b>HSS TOOL BITS, GEAR CUTTER &amp; BROACHES</b>	<b>70-74</b>
HSS tool bits, square	70
HSS tool bits, round	70
HSS tool bits, rectangular	70
HSS ' T ' type cut off blade	71
HSS cut-off blade	71
Module involute gear cutter	72
Gear hob	73
Hexagon push broaches	73
Square push broaches	73
Keyway push broaches	74
Keyway broaches shims	74
Keyway broaches bushing	74
<b>CONSTRUCTION, WOOD WORKING TOOL &amp; SAW</b>	<b>75-82</b>
Masonry drill	75
Hammer drill, SDS-Plus shank	76
Hammer drill, SDS-Max shank	76
Hammer drill, Hex shank	76
Hammer drill, Spline shank	76

INDEX	PAGE
<b>CONSTRUCTION &amp; WOOD WORKING &amp; SAW</b>	<b>75-82</b>
Construction core drill	77
Construction core drill accessories	77
Chisels	78
Carbide tipped hole saw	78
HSS hole saw	78
Bi-metal hole saw	78
Bi-metal hole saw kits	79
Bi-metal hole saw arbor & accessories	80
Glass drill	80
Diamond coated hole saw for glass	80
Carbon steel hole saw kits	80
Lock installation kits	80
Brad point bits	81
Spade bits	81
Wood auger bits	81
Forstner bits	81
Jig saw blade	82
Bi-metal reciprocating saw blade	82
Hand hack saw blade	82
Power hack saw blade	82
<b>FILES &amp; BURR</b>	<b>83-89</b>
Steel files	83-84
Needle files	85
Die sinker rifflers	85
Silversmith and dies maker's rifflers	85
Diamond needle files & set	86
Diemaker's diamond riffler file set	86
Diamond pointer sets	86
Carbide burr	87
Carbide burr set	88
HSS burr	88
Rotary burr set	88
Rotary files	89
HSS enlarging cutter	89
Rotary rasp sets	89
Drum rasp	89
<b>MACHINE TOOL ACCESSORIES</b>	<b>90-104</b>
R8 , 5C, morse taper & DIN6341 collects	90
ER collects & collects sets	91
EOC collects	91
TG collects	91
ER collect chuck	91-92
ER collect chuck set	92-93
EOC collect chuck set	93
End mill adaptor	93
Shell end mill arbor	93-94
7:24 milling chuck arbor	94-95
Drill chuck arbor	95-97
Morse taper sleeve	97-98
Dead centers	99
Live centers	99-100
Drill chucks	100
Tap chucks	101-102
Tool vise	102
K11 self center 3-jaw chuck	103
k12 self center 4-jaw chuck	104
k72 independent 4-jaw chuck	104

## STC008, HSS STRAIGHT SHANK TWIST DRILL, Jobber Series

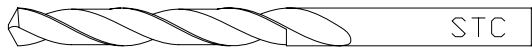
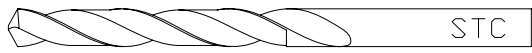
NOTE.: Standard delivery with 118° point, please specify when ordering 135° split point drills.

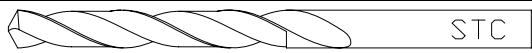
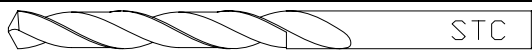
Order No.	Material	Description	Photo
101- 001	HSS	HSS Twist Drill, Black Finish, Roll Forged	
101- 002	HSS	HSS Twist Drill, Black Finish, Fully Ground	
101- 003	HSS	HSS Twist Drill, Bright Finish, Polished	
101- 004	HSS	HSS Twist Drill, Bright Finish, Fully Ground	
101- 005	HSS	HSS Twist Drill, Tin-coated, polished	
101- 006	HSS, HSS-E	HSS Twist Drill, Tin-coated, Fully Ground	
101- 007	M35	HSS-Cobalt5% Twist Drill, Fully Ground	
101- 008	M42	HSS-Cobalt8% Twist Drill, Fully Ground	

### HSS STRAIGHT SHANK TWIST DRILL , JOBBER LENGTH ( DIN338, GOST10902, ISO235)

Size	Flute Length	Overall Length	Size	Flute Length	Overall Length	Size	Flute Length	Overall Length	Size	Flute Length	Overall Length	Size	Flute Length	Overall Length
0.25	3	19	2.15			5.10			8.90			12.70		
0.30			2.20			5.20	52	86	9.00			12.80		
0.35	4	19	2.25	27	53	5.30			9.10			12.90		
0.40			2.30			5.40			9.20	81	125	13.00	101	151
0.45	5	20	2.35			5.50			9.30			13.10		
0.50	6	22	2.40			5.60			9.40			13.20		
0.55			2.45			5.70	57	93	9.50			13.30		
0.60	7	24	2.50	30	57	5.80			9.60			13.40		
0.65			2.55			5.90			9.70			13.50		
0.70	8	26	2.60			6.00			9.80			13.60		
0.75	9	28	2.65			6.10			9.90			13.70	108	160
0.80			2.70			6.20			10.00			13.80		
0.85	10	30	2.75			6.30			10.10	87	133	13.90		
0.90			2.80			6.40	63	101	10.20			14.00		
0.95	11	32	2.85	33	61	6.50			10.30			14.25		
1.00			2.90			6.60			10.40			14.50	114	169
1.05	12	34	2.95			6.70			10.50			14.75		
1.10			3.00			6.80			10.60			15.00		
1.15	14	36	3.10			6.90			10.70			15.25		
1.20			3.20	36	65	7.00			10.80			15.50		
1.25	16	38	3.30			7.10	69	109	10.90			15.75	120	178
1.30			3.40			7.20			11.00			16.00		
1.35			3.50	39	70	7.30			11.10			16.25		
1.40	18	40	3.60			7.40			11.20	94	142	16.50	125	184
1.45			3.70			7.50			11.30			16.75		
1.50			3.80			7.60			11.40			17.00		
1.55			3.90			7.70			11.50			17.25		
1.60	20	43	4.00	43	75	7.80			11.60			17.50	130	191
1.65			4.10			7.90			11.70			17.75		
1.70			4.20			8.00			11.80			18.00		
1.75			4.30			8.10	75	117	11.90			18.25		
1.80	22	46	4.40			8.20			12.00			18.50		
1.85			4.50	47	80	8.30			12.10			18.75	135	198
1.90			4.60			8.40			12.20			19.00		
1.95			4.70			8.50			12.30	101	151	19.25		
2.00	24	49	4.80			8.60			12.40			19.50	140	205
2.05			4.90	52	86	8.70	81	125	12.50			19.75		
2.10			5.00			8.80			12.60			20.00		

## STC008, HSS STRAIGHT SHANK TWIST DRILL, Jobber Length

NOTE.: Standard delivery with 118° point, please specify when ordering 135° split point drills.

INCH SIZE (ASME 94B.11)

FRACTIONAL SIZE

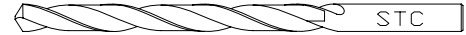

Size	Flute Length	Overall Length
1/64"	3/16"	3/4"
1/32"	1/2"	1-3/8"
3/64"	3/4"	1-3/4"
1/16"	7/8"	1-7/8"
5/64"	1"	2"
3/32"	1-1/4"	2-1/4"
7/64"	1-1/2"	2-5/8"
1/8"	1-5/8"	2-3/4"
9/64"	1-3/4"	2-7/8"
5/32"	2"	3-1/8"
11/64"	2-1/8"	3-1/4"

Size	Flute Length	Overall Length
3/16"	2-5/16"	3-1/2"
13/64"	2-7/16"	3-5/8"
7/32"	2-1/2"	3-3/4"
15/64"	2-5/8"	3-7/8"
1/4"	2-3/4"	4"
17/64"	2-7/8"	4-1/8"
9/32"	2-15/16"	4-1/4"
19/64"	3-1/16"	4-3/8"
5/16"	3-3/16"	4-1/2"
21/64"	3-5/16"	4-5/8"
11/32"	3-7/16"	4-3/4"

Size	Flute Length	Overall Length
23/64"	3-1/2"	4-7/8"
3/8"	3-5/8"	5"
25/64"	3-3/4"	5-1/8"
13/32"	3-7/8"	5-1/4"
27/64"	3-15/16"	5-3/8"
7/16"	4-1/16"	5-1/2"
29/64"	4-3/16"	5-5/8"
15/32"	4-5/16"	5-3/4"
31/64"	4-3/8"	5-7/8"
1/2"	4-1/2"	6"
33/64"	4-13/16"	6-5/8"

Size	Flute Length	Overall Length
17/32"	4-13/16"	6-5/8"
35/64"	4-13/16"	6-5/8"
9/16"	4-13/16"	6-5/8"
37/64"	5-3/16"	7-1/8"
19/32"	5-3/16"	7-1/8"
39/64"	5-3/16"	7-1/8"
5/8"	5-3/16"	7-1/8"
41/64"	5-3/16"	7-1/8"
21/32"	5-3/16"	7-1/8"
43/64"	5-5/8"	7-5/8"
11/16"	5-5/8"	7-5/8"

LETTER SIZE

Size	Flute Length	Overall Length
A	2-5/8"	3-7/8"
B	2-3/4"	4"
C	2-3/4"	4"
D	2-3/4"	4"
E	2-3/4"	4"
F	2-7/8"	4-1/8"
G	2-7/8"	4-1/8"

Size	Flute Length	Overall Length
H	2-7/8"	4-1/8"
I	2-7/8"	4-1/8"
J	2-7/8"	4-1/8"
K	2-15/16"	4-1/4"
L	2-15/16"	4-1/4"
M	3-1/16"	4-3/8"
N	3-1/16"	4-3/8"

Size	Flute Length	Overall Length
O	3-3/16"	4-1/2"
P	3-5/16"	4-5/8"
Q	3-7/16"	4-3/4"
R	3-7/16"	4-3/4"
S	3-1/2"	4-7/8"
T	3-1/2"	4-7/8"
U	3-5/8"	5"

Size	Flute Length	Overall Length
V	3-5/8"	5"
W	3-3/4"	5-1/8"
X	3-3/4"	5-1/8"
Y	3-7/8"	5-1/4"
Z	3-7/8"	5-1/4"

WIRE GAUGE SIZE

Size	Flute Length	Overall Length
1	2-5/8"	3-7/8"
2	2-5/8"	3-7/8"
3	2-1/2"	3-3/4"
4	2-1/2"	3-3/4"
5	2-1/2"	3-3/4"
6	2-1/2"	3-3/4"
7	2-7/16"	3-5/8"
8	2-7/16"	3-5/8"
9	2-7/16"	3-5/8"
10	2-7/16"	3-5/8"
11	2-5/16"	3-1/2"
12	2-5/16"	3-1/2"
13	2-5/16"	3-1/2"
14	2-3/16"	3-3/8"
15	2-3/16"	3-3/8"
16	2-3/16"	3-3/8"
17	2-3/16"	3-3/8"
18	2-1/8"	3-1/4"
19	2-1/8"	3-1/4"
20	2-1/8"	3-1/4"

Size	Flute Length	Overall Length
21	2-1/8"	3-1/4"
22	2"	3-1/8"
23	2"	3-1/8"
24	2"	3-1/8"
25	1-7/8"	3"
26	1-7/8"	3"
27	1-7/8"	3"
28	1-3/4"	2-7/8"
29	1-3/4"	2-7/8"
30	1-5/8"	2-3/4"
31	1-5/8"	2-3/4"
32	1-5/8"	2-3/4"
33	1-1/2"	2-5/8"
34	1-1/2"	2-5/8"
35	1-1/2"	2-5/8"
36	1-7/16"	2-1/2"
37	1-7/16"	2-1/2"
38	1-7/16"	2-1/2"
39	1-3/8"	2-3/8"
40	1-3/8"	2-3/8"

Size	Flute Length	Overall Length
41	1-3/8"	2-3/8"
42	1-1/4"	2-1/4"
43	1-1/4"	2-1/4"
44	1-1/8"	2-1/8"
45	1-1/8"	2-1/8"
46	1-1/8"	2-1/8"
47	1"	2"
48	1"	2"
49	1"	2"
50	1"	2"
51	1"	2"
52	7/8"	1-7/8"
53	7/8"	1-7/8"
54	7/8"	1-7/8"
55	7/8"	1-7/8"
56	3/4"	1-3/4"
57	3/4"	1-3/4"
58	11/16"	1-5/8"
59	11/16"	1-5/8"
60	11/16"	1-5/8"

Size	Flute Length	Overall Length
61	11/16"	1-5/8"
62	5/8"	1-1/2"
63	5/8"	1-1/2"
64	5/8"	1-1/2"
65	5/8"	1-1/2"
66	1/2"	1-3/8"
67	1/2"	1-3/8"
68	1/2"	1-3/8"
69	1/2"	1-3/8"
70	3/8"	1-1/4"
71	3/8"	1-1/4"
72	5/16"	1-1/8"
73	5/16"	1-1/8"
74	1/4"	1"
75	1/4"	1"
76	3/16"	7/8"
77	3/16"	7/8"
78	3/16"	7/8"
79	1/8"	3/4"
80	1/8"	3/4"

## STC014-1, HSS PARALLEL SHANK TWIST DRILL, Stub Series

NOTE.: Standard delivery with 118° point, please specify when ordering 135° split point drills.

DIN 1897, GOST4010



Size	Flute Length	Overall Length
0.5	3	20
0.8	5	24
1.0	6	26

Size	Flute Length	Overall Length
1.2	8	30
1.5	9	32
1.8	11	36

Size	Flute Length	Overall Length
2.0	12	38
2.2	13	40
2.5	14	43

Size	Flute Length	Overall Length
2.8	16	46
3.0	18	49

## STC014-1, HSS PARALLEL SHANK TWIST DRILL, Stub Series

NOTE.: Standard delivery with 118° point, please specify when ordering 135° split point drills.

DIN 1897, GOST4010



Size	Flute Length	Overall Length
3.5	20	52
3.8	22	55
4.0		
4.2		
4.5	24	58
4.8	26	62
5.0	26	62
5.2		
5.5		
5.8	28	66
6.0		
6.2	31	70
6.5		
6.8	34	74
7.0		

Size	Flute Length	Overall Length
7.2	34	74
7.5	34	74
7.8	37	79
8.0		
8.2		
8.5		
8.8	40	84
9.0		
9.2		
9.5		
9.8		
10.0	43	89
10.2		
10.5		
10.8		
10.8	47	95

Size	Flute Length	Overall Length
11.0	47	95
11.2		
11.5		
11.8		
12.0		
12.2	51	102
12.5		
12.8		
13.0		
13.2		
13.5	54	107
13.8		
14.0		
14.5		
15.0	56	111

Size	Flute Length	Overall Length
15.5	58	115
16.0		
16.5		
17.0	60	119
17.5	62	123
18.0		
18.5	64	127
19.0		
19.5		
20.0	66	131
22.0	70	141
24.0	75	151
25.0		

## STC014-2, HSS STRAIGHT SHANK TWIST DRILL, Screw Machine Length

NOTE.: Standard delivery with 118° point, please specify when ordering 135° split point drills.

ANSI / ASME B94.11M-1993

FRACTIONAL SIZE



Size	Flute Length	Overall Length
3/64"	1/2"	1-3/8"
1/16"	5/8"	1-5/8"
5/64"	11/16"	1-11/16"
3/32"	3/4"	1-3/4"
7/64"	13/16"	1-13/16"
1/8"	7/8"	1-7/8"
9/64"	15/16"	1-15/16"
5/32"	1"	2-1/16"
11/64"	1-1/16"	2-1/8"
3/16"	1-1/8"	2-3/16"
13/64"	1-3/16"	2-1/4"
7/32"	1-1/4"	2-3/8"
15/64"	1-5/16"	2-7/16"
1/4"	1-3/8"	2-1/2"
17/64"	1-7/16"	2-5/8"
9/32"	1-1/2"	2-11/16"
19/64"	1-9/16"	2-3/4"

Size	Flute Length	Overall Length
5/16"	1-5/8"	2-13/16"
21/64"	1-11/16"	2-15/16"
11/32"	1-11/16"	3"
23/64"	1-3/4"	3-1/16"
3/8"	1-13/16"	3-1/8"
25/64"	1-7/8"	3-1/4"
13/32"	1-15/16"	3-5/16"
27/64"	2"	3-3/8"
7/16"	2-1/16"	3-7/16"
29/64"	2-1/8"	3-9/16"
15/32"	2-1/8"	3-5/8"
31/64"	2-3/16"	3-11/16"
1/2"	2-1/4"	3-3/4"
33/64"	2-3/8"	3-7/8"
17/32"	2-3/8"	3-7/8"
35/64"	1-1/2"	4"
9/16"	1-1/2"	4"

Size	Flute Length	Overall Length
37/64"	2-5/8"	4-1/8"
19/32"	2-5/8"	4-1/8"
39/64"	2-3/4"	4-1/4"
5/8"	2-3/4"	4-1/4"
41/64"	2-7/8"	4-1/2"
21/32"	2-7/8"	4-1/2"
43/64"	2-7/8"	4-5/8"
11/16"	2-7/8"	4-5/8"
45/64"	3"	4-3/4"
23/32"	3"	4-3/4"
47/64"	3-1/8"	5"
3/4"	3-1/8"	5"
49/64"	3-1/4"	5-1/8"
25/32"	3-1/4"	5-1/8"
51/64"	3-3/8"	5-1/4"
13/16"	3-3/8"	5-1/4"
53/64"	3-1/2"	5-3/8"

Size	Flute Length	Overall Length
27/32"	3-1/2"	5-3/8"
55/64"	3-1/2"	5-1/2"
7/8"	3-1/2"	5-1/2"
57/64"	3-5/8"	5-5/8"
29/32"	3-5/8"	5-5/8"
59/64"	3-3/4"	5-3/4"
15/16"	3-3/4"	5-3/4"
61/64"	3-7/8"	5-7/8"
31/32"	3-7/8"	5-7/8"
63/64"	4"	6"
1"	4"	6"
1-1/16"	4"	6-1/4"
1-1/8"	4"	6-3/8"
1-3/16"	4-1/4"	6-5/8"
1-1/4"	4-3/8"	6-3/4"
1-3/8"	4-1/2"	7-1/8"
1-1/2"	4-7/8"	7-1/2"

## WIRE GAUGE SIZES

Size	Flute Length	Overall Length
1	1-5/16"	2-7/16"
2	1-5/16"	2-7/16"
3	1-1/4"	2-3/8"
4	1-1/4"	2-3/8"
5	1-1/4"	2-3/8"
6	1-1/4"	2-3/8"
7	1-3/16"	2-1/4"
8	1-3/16"	2-1/4"
9	1-3/16"	2-1/4"
10	1-3/16"	2-1/4"
11	1-3/16"	2-1/4"
12	1-3/16"	2-1/4"
13	1-1/8"	2-3/16"
14	1-1/8"	2-3/16"
15	1-1/8"	2-3/16"

Size	Flute Length	Overall Length
16	1-1/8"	2-3/16"
17	1-1/8"	2-3/16"
18	1-1/16"	2-1/8"
19	1-1/16"	2-1/8"
20	1-1/16"	2-1/8"
21	1-1/16"	2-1/8"
22	1-1/16"	2-1/8"
23	1"	2-1/16"
24	1"	2-1/16"
25	1"	2-1/16"
26	1"	2-1/16"
27	1"	2-1/16"
28	15/16"	1-15/16"
29	15/16"	1-15/16"
30	15/16"	1-15/16"

Size	Flute Length	Overall Length
31	7/8"	1-7/8"
32	7/8"	1-7/8"
33	7/8"	1-7/8"
34	7/8"	1-7/8"
35	7/8"	1-7/8"
36	13/16"	1-13/16"
37	13/16"	1-13/16"
38	13/16"	1-13/16"
39	13/16"	1-13/16"
40	13/16"	1-13/16"
41	13/16"	1-13/16"
42	3/4"	1-3/4"
43	3/4"	1-3/4"
44	3/4"	1-3/4"
45	3/4"	1-3/4"

Size	Flute Length	Overall Length
46	3/4"	1-3/4"
47	3/4"	1-3/4"
48	11/16"	1-11/16"
49	11/16"	1-11/16"
50	11/16"	1-11/16"
51	11/16"	1-11/16"
52	11/16"	1-11/16"
53	5/8"	1-5/8"
54	5/8"	1-5/8"
55	5/8"	1-5/8"
56	1/2"	1-3/8"
57	1/2"	1-3/8"
58	1/2"	1-3/8"
59	1/2"	1-3/8"
60	1/2"	1-3/8"

## STC014-2, HSS STRAIGHT SHANK TWIST DRILL, Screw Machine Length

NOTE.: Standard delivery with 118° point, please specify when ordering 135° split point drills.

ANSI / ASME B94.11M-1993

LETTER SIZES



Size	Flute Length	Overall Length
A	1-5/16"	2-7/16"
B	1-3/8"	2-1/2"
C	1-3/8"	2-1/2"
D	1-3/8"	2-1/2"
E	1-3/8"	2-1/2"
F	1-7/16"	2-5/8"
G	1-7/16"	2-5/8"

Size	Flute Length	Overall Length
H	1-1/2"	2-11/16"
I	1-1/2"	2-11/16"
J	1-1/2"	2-11/16"
K	1-1/2"	2-11/16"
L	1-9/16"	2-3/4"
M	1-9/16"	2-3/4"
N	1-5/8"	2-13/16"

Size	Flute Length	Overall Length
O	1-11/16"	2-15/16"
P	1-11/16"	2-15/16"
Q	1-11/16"	3"
R	1-11/16"	3"
S	1-3/4"	3-1/16"
T	1-3/4"	3-1/16"
U	1-13/16"	3-1/8"

Size	Flute Length	Overall Length
V	1-7/8"	3-1/4"
W	1-7/8"	3-1/4"
X	1-15/16"	3-5/16"
Y	1-15/16"	3-5/16"
Z	2"	3-3/8"

## STC014-3, HSS PARALLEL SHANK TWIST DRILL, Long Series

NOTE.: Standard delivery with 118° point, please specify when ordering 135° split point drills.

DIN340, GOST886

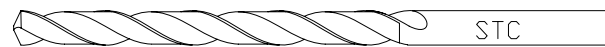

Size	Flute Length	Overall Length
1.0	33	56
1.1	37	60
1.2	41	65
1.3		
1.4	45	70
1.5		
1.6	50	76
1.7		
1.8	53	80
1.9		
2.0	56	85
2.1		
2.2	59	90
2.3		
2.4	62	95
2.5		
2.6	66	100
2.7		
2.8	69	106
2.9		
3.0	73	112
3.1		
3.2	78	119
3.3		
3.4	82	126
3.5		
3.6	87	132
3.7		
3.8	91	139
3.9		
4.0	97	148
4.1		
4.2	102	156
4.3		
4.4	109	165
4.5		
4.6	115	175
4.7		
4.8		

Size	Flute Length	Overall Length
4.9	87	132
5.0		
5.1		
5.2		
5.3	91	139
5.4		
5.5		
5.6		
5.7	97	148
5.8		
5.9		
6.0		
6.1	102	156
6.2		
6.3		
6.4		
6.5	109	165
6.6		
6.7		
6.8		
6.9	115	175
7.0		
7.1		
7.2		
7.3		
7.4		
7.5		
7.6		
7.7		
7.8		
7.9		
8.0		
8.1		
8.2		
8.3		
8.4		
8.5		
8.6		
8.7		

Size	Flute Length	Overall Length
8.8	115	175
8.9		
9.0		
9.1		
9.2		
9.3		
9.4	121	184
9.5		
9.6		
9.7		
9.8		
9.9		
10.0	128	195
10.1		
10.2		
10.3		
10.4		
10.5		
10.6	134	205
10.7		
10.8		
10.9		
11.0		
11.1		
11.2		
11.3		
11.4		
11.5		
11.6		
11.7		
11.8		
11.9		
12.0		
12.1		
12.2		
12.3		
12.4		
12.5		
12.6		

Size	Flute Length	Overall Length
12.7	134	205
12.8		
12.9		
13.0		
13.1		
13.2		
13.3	140	214
13.4		
13.5		
13.6		
13.7		
13.8		
13.9	144	220
14.0		
14.25		
14.50		
14.75		
15.00		
15.25	149	227
15.50		
15.75		
16.00		
16.25		
16.50		
16.75	154	235
17.00		
17.25		
17.50		
17.75		
18.00		
18.25	158	241
18.50		
18.75		
19.00		
19.25		
19.50		
19.75	162	247
20.00		
	166	254

## STC014-4, HSS STRAIGHT SHANK TWIST DRILL, Taper Length

NOTE.: Standard delivery with 118° point, please specify when ordering 135° split point drills.

ANSI / ASME B94.11M-1993

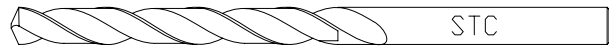

### FRACTIONAL SIZE

Size	Flute Length	Overall Length
1/16"	1-3/4"	3"
5/64"	2"	3-3/4"
3/32"	2-1/4"	4-1/4"
7/64"	2-1/2"	4-5/8"
1/8"	2-3/4"	5-1/8"
9/64"	3"	5-3/8"
5/32"	3"	5-3/8"
11/64"	3-3/8"	5-3/4"
3/16"	3-3/8"	5-3/4"
13/64"	3-5/8"	6"
7/32"	3-5/8"	6"
15/64"	3-3/4"	6-1/8"
1/4"	3-3/4"	6-1/8"
17/64"	3-7/8"	6-1/4"
9/32"	3-7/8"	6-1/4"
19/64"	4"	6-3/8"
5/16"	4"	6-3/8"
21/64"	4-1/8"	6-1/2"
11/32"	4-1/8"	6-1/2"

Size	Flute Length	Overall Length
23/64"	4-1/4"	6-3/4"
3/8"	4-1/4"	6-3/4"
25/64"	4-3/8"	7"
13/32"	4-3/8"	7"
27/64"	4-5/8"	7-1/4"
7/16"	4-5/8"	7-1/4"
29/64"	4-3/4"	7-1/2"
15/32"	4-3/4"	7-1/2"
31/64"	4-3/4"	7-3/4"
1/2"	4-3/4"	7-3/4"
33/64"	4-3/4"	8"
17/32"	4-3/4"	8"
35/64"	4-7/8"	8-1/4"
9/16"	4-7/8"	8-1/4"
37/64"	4-7/8"	8-3/4"
19/32"	4-7/8"	8-3/4"
39/64"	4-7/8"	8-3/4"
5/8"	4-7/8"	8-3/4"
41/64"	5-1/8"	9"

Size	Flute Length	Overall Length
21/32"	5-1/8"	9"
43/64"	5-3/8"	9-1/4"
11/16"	5-3/8"	9-1/4"
45/64"	5-3/8"	9-1/2"
23/32"	5-3/8"	9-1/2"
47/64"	5-7/8"	9-3/4"
3/4"	5-7/8"	9-3/4"
49/64"	6"	9-7/8"
25/32"	6"	9-7/8"
51/64"	6-1/8"	10"
13/32"	6-1/8"	10"
53/64"	6-1/8"	10"
27/32"	6-1/8"	10"
55/64"	6-1/8"	10"
7/8"	6-1/8"	10"
57/64"	6-1/8"	10"
29/32"	6-1/8"	10"
59/64"	6-1/8"	10-3/4"
15/16"	6-1/8"	10-3/4"

Size	Flute Length	Overall Length
61/64"	6-3/8"	11"
31/32"	6-3/8"	11"
63/64"	6-3/8"	11"
1"	6-3/8"	11"
1-1/32"	6-1/2"	11-1/8"
1-1/16"	6-5/8"	11-1/4"
1-3/32"	6-7/8"	11-1/2"
1-1/8"	7-1/8"	11-3/4"
1-5/32"	7-1/4"	11-7/8"
1-3/16"	7-3/8"	12"
1-1/4"	7-7/8"	12-1/2"
1-5/16"	8-5/8"	14-1/4"
1-3/8"	8-7/8"	14-1/2"
1-7/16"	9-1/8"	14-3/4"
1-1/2"	9-3/8"	15"
1-5/8"	9-7/8"	15-5/8"
1-3/4"	10-1/2"	16-1/4"
1-7/8"	10-3/4"	16-1/2"
2"	10-3/4"	16-5/8"

### LETTER SIZE

Size	Flute Length	Overall Length
A	3-3/4"	6-1/8"
B	3-3/4"	6-1/8"
C	3-3/4"	6-1/8"
D	3-3/4"	6-1/8"
E	3-3/4"	6-1/8"
F	3-7/8"	6-1/4"
G	3-7/8"	6-1/4"

Size	Flute Length	Overall Length
H	3-7/8"	6-1/4"
I	3-7/8"	6-1/4"
J	3-7/8"	6-1/4"
K	3-7/8"	6-1/4"
L	4"	6-3/8"
M	4"	6-3/8"
N	4"	6-3/8"

Size	Flute Length	Overall Length
O	4-1/8"	6-1/2"
P	4-1/8"	6-1/2"
Q	4-1/8"	6-1/2"
R	4-1/8"	6-1/2"
S	4-1/4"	6-3/4"
T	4-1/4"	6-3/4"
U	4-1/4"	6-3/4"

Size	Flute Length	Overall Length
V	4-3/8"	7"
W	4-3/8"	7"
X	4-3/8"	7"
Y	4-3/8"	7"
Z	4-5/8"	7-1/4"

### WIRE GAUGE SIZE

Size	Flute Length	Overall Length
1	3-3/4"	6-1/8"
2	3-3/4"	6-1/8"
3	3-5/8"	6"
4	3-5/8"	6"
5	3-5/8"	6"
6	3-5/8"	6"
7	3-5/8"	6"
8	3-5/8"	6"
9	3-5/8"	6"
10	3-5/8"	6"
11	3-5/8"	6"
12	3-5/8"	6"
13	3-3/8"	5-3/4"
14	3-3/8"	5-3/4"
15	3-3/8"	5-3/4"

Size	Flute Length	Overall Length
16	3-3/8"	5-3/4"
17	3-3/8"	5-3/4"
18	3-3/8"	5-3/4"
19	3-3/8"	5-3/4"
20	3-3/8"	5-3/4"
21	3-3/8"	5-3/4"
22	3-3/8"	5-3/4"
23	3"	5-3/8"
24	3"	5-3/8"
25	3"	5-3/8"
26	3"	5-3/8"
27	3"	5-3/8"
28	3"	5-3/8"
29	3"	5-3/8"
30	3"	5-3/8"

Size	Flute Length	Overall Length
31	2-3/4"	5-1/8"
32	2-3/4"	5-1/8"
33	2-3/4"	5-1/8"
34	2-3/4"	5-1/8"
35	2-3/4"	5-1/8"
36	2-1/2"	4-5/8"
37	2-1/2"	4-5/8"
38	2-1/2"	4-5/8"
39	2-1/2"	4-5/8"
40	2-1/2"	4-5/8"
41	2-1/2"	4-5/8"
42	2-1/4"	4-1/4"
43	2-1/4"	4-1/4"
44	2-1/4"	4-1/4"
45	2-1/4"	4-1/4"

Size	Flute Length	Overall Length
46	2-1/4"	4-1/4"
47	2-1/4"	4-1/4"
48	2"	3-3/4"
49	2"	3-3/4"
50	2"	3-3/4"
51	2"	3-3/4"
52	2"	3-3/4"
53	1-3/4"	3"
54	1-3/4"	3"
55	1-3/4"	3"
56	1-1/8"	2-1/4"
57	1-1/8"	2-1/4"
58	1-1/8"	2-1/4"
59	1-1/8"	2-1/4"
60	1-1/8"	2-1/4"

## STC024, SOLID CARBIDE DRILL FOR PRINT CIRCUIT BOARD

Note: Shank Diameter is 1/8". Material HSS is available .



Size	Flute Length	Overall Length
0.3	5	1-1/2"
0.35	5	1-1/2"
0.4	6.5	1-1/2"
0.45	6.5	1-1/2"
0.5	8.5	1-1/2"
0.55	8.5	1-1/2"
0.6	9.5	1-1/2"
0.65	9.5	1-1/2"
0.7	10.5	1-1/2"

Size	Flute Length	Overall Length
0.75	10.5	1-1/2"
0.8	10.5	1-1/2"
0.85	10.5	1-1/2"
0.9	10.5	1-1/2"
0.95	10.5	1-1/2"
1	10.5	1-1/2"
1.05	10.5	1-1/2"
1.1	10.5	1-1/2"
1.15	10.5	1-1/2"

Size	Flute Length	Overall Length
1.2	10.5	1-1/2"
1.25	10.5	1-1/2"
1.3	12	1-1/2"
1.35	12	1-1/2"
1.4	12	1-1/2"
1.45	12	1-1/2"
1.5	12	1-1/2"
1.55	12	1-1/2"
1.6	12	1-1/2"

Size	Flute Length	Overall Length
1.65	12	1-1/2"
1.7	12	1-1/2"
1.75	12	1-1/2"
1.8	12	1-1/2"
1.85	12	1-1/2"
1.9	12	1-1/2"
1.95	12	1-1/2"
2	12	1-1/2"

## STC022-2, HSS DOUBLE END DRILL, Inch Sizes

Note: Standard delivery with 135° split point.

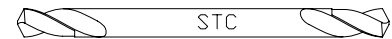

Size	Flute Length	Overall Length
1/16"	3/8"	1-1/2"
5/64"	3/8"	1-1/2"
3/32"	1/2"	1-11/16"
7/64"	1/2"	1-13/16"

Size	Flute Length	Overall Length
1/8"	1/2"	1-13/16"
9/64"	5/8"	2-1/16"
5/32"	5/8"	2-3/16"
11/64"	5/8"	2-5/16"

Size	Flute Length	Overall Length
3/16"	5/8"	2-5/16"
7/32"	3/4"	2-5/8"
1/4"	3/4"	2-7/8"
No.7	5/8"	2-5/16"

Size	Flute Length	Overall Length
No.11	5/8"	2-5/16"
No.20	5/8"	2-3/16"
No.26	5/8"	2-1/16"
No.27	5/8"	2-1/16"
No.30	1/2"	1-13/16"

## STC022-1, HSS DOUBLE END DRILL, Metric Sizes

Note: Standard delivery with 135° split point.

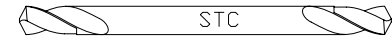

Size	Flute Length	Overall Length
2.0	10	38
2.5	13	43
3.0	13	46
3.1	13	46
3.2	13	49
3.25	13	49

Size	Flute Length	Overall Length
3.3	13	49
3.5	16	52
4.0	16	55
4.1	16	55
4.2	16	55
4.5	16	58

Size	Flute Length	Overall Length
4.8	16	62
5	16	62
5.2	16	62
5.5	19	66
6	19	66
6.1	19	66

Size	Flute Length	Overall Length
6.2	19	66
6.5	19	66
6.2	19	74
6.3	19	74
6.4	19	74
6.5	19	74

## STC014M, HSS PARALLEL SHANK TWIST DRILL, EXTRA LONG SERIES

DIN1869



Size	Flute Length	Overall Length
DIN1869-1		
1.6	75	115
1.7		
1.8		
1.9	80	120
2	85	125
2.5		
3.0	100	150
3.5	115	165
4.0	120	175
4.5	125	185
5.0	135	195
5.5	140	205
6.0		
6.5		
7.0	150	215
7.5	155	225
8.0	165	240

Size	Flute Length	Overall Length
8.5	165	240
9	175	250
9.5		
10.0	185	265
10.5	195	280
11.0		
11.5		
12.0	205	295
12.5		
13.0		
13.5		
DIN1869-2		
3.0	130	190
3.5	145	210
4.0	150	220
4.5	160	235
5.0	170	245
5.5	180	260
6.0		

Size	Flute Length	Overall Length
6.5	190	275
7.0	200	290
7.5		
8.0	210	305
8.5	220	320
9.0		
9.5		
10.0	235	340
10.5	250	365
11.0	250	365
11.5		
12.0	260	375
12.5		
13.0		
DIN1869-3		
3.5	180	265
4.0	190	280
4.5	200	295

Size	Flute Length	Overall Length
5.0	210	315
5.5	225	330
6.0		
6.5	235	350
7.0	250	370
7.5		
8.0		
8.5	265	390
9.0	280	410
9.5		
10.0		
10.5	310	455
11.0		
11.5		
12.0	330	480
12.5		
13.0		



## STC179-1M, HSS DRILL BLANK



HSS SPEED STEEL, HARDNESS: HRC63-66

METRIC SIZES

Size	Overall Length	Size	Overall Length	Size	Overall Length	Size	Overall Length	Size	Overall Length	Size	Overall Length
0.50	22	1.65	43	3.60	70	6.90	109	10.20	133	13.50	160
0.52	22	1.70	43	3.70	70	7.00	109	10.30	133	13.60	160
0.55	24	1.75	46	3.80	75	7.10	109	10.40	133	13.70	160
0.58	24	1.80	46	3.90	75	7.20	109	10.50	133	13.80	160
0.60	24	1.85	46	4.00	75	7.30	109	10.60	133	13.90	160
0.62	26	1.90	46	4.10	75	7.40	109	10.70	142	14.00	160
0.65	26	1.95	49	4.20	75	7.50	109	10.80	142	14.25	169
0.68	28	2.00	49	4.30	80	7.60	117	10.90	142	14.50	169
0.70	28	2.05	49	4.40	80	7.70	117	11.00	142	14.75	169
0.72	28	2.10	49	4.50	80	7.80	117	11.10	142	15.00	169
0.75	28	2.15	53	4.60	80	7.90	117	11.20	142	15.25	178
0.78	30	2.20	53	4.70	80	8.00	117	11.30	142	15.50	178
0.80	30	2.25	53	4.80	86	8.10	117	11.40	142	15.75	178
0.82	30	2.30	53	4.90	86	8.20	117	11.50	142	16.00	178
0.85	30	2.35	53	5.00	86	8.30	117	11.60	142	16.25	184
0.88	32	2.40	57	5.10	86	8.40	117	11.70	142	16.50	184
0.90	32	2.45	57	5.20	86	8.50	117	11.80	142	16.75	184
0.92	32	2.50	57	5.30	86	8.60	125	11.90	151	17.00	184
0.95	32	2.55	57	5.40	93	8.70	125	12.00	151	17.25	191
0.98	34	2.60	57	5.50	93	8.80	125	12.10	151	17.50	191
1.00	34	2.65	57	5.60	93	8.90	125	12.20	151	17.75	191
1.05	34	2.70	61	5.70	93	9.00	125	12.30	151	18.00	191
1.10	36	2.75	61	5.80	93	9.10	125	12.40	151	18.25	198
1.15	36	2.80	61	5.90	93	9.20	125	12.50	151	18.50	198
1.20	38	2.85	61	6.00	93	9.30	125	12.60	151	18.75	198
1.25	38	2.90	61	6.10	101	9.40	125	12.70	151	19.00	198
1.30	38	2.95	61	6.20	101	9.50	125	12.80	151	19.25	205
1.35	40	3.00	61	6.30	101	9.60	133	12.90	151	19.50	205
1.40	40	3.10	65	6.40	101	9.70	133	13.00	151	19.75	205
1.45	40	3.20	65	6.50	101	9.80	133	13.10	151	20.00	205
1.50	40	3.30	65	6.60	101	9.90	133	13.20	151		
1.55	43	3.40	70	6.70	101	10.00	133	13.30	160		
1.60	43	3.50	70	6.80	109	10.10	133	13.40	160		

Tolerance Limits

0.0 - 3.0mm	+0 / -0.014mm	10.1-18.0mm	+0 / -0.027mm
3.1 - 6.0mm	+0 / -0.018mm	18.0-20.0mm	+0 / -0.033mm
6.1 -10.0mm	+0 / -0.022mm		

## STC179-1A, HSS DRILL BLANK, JOBBER LENGTH

High Speed Steel, Hardness: HRC63-66.

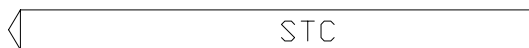

Tolerance Limits

0" - 0.250"	+0.0000" - 0.0005"
0.251" - 0.3906"	+0.0000" - 0.0009"
0.3910" - 1.000"	+0.0000" - 0.0010"

FRACTIONAL SIZES

Size	Overall Length	Size	Overall Length	Size	Overall Length	Size	Overall Length	Size	Overall Length	Size	Overall Length
1/64"	3/4"	3/16"	3-1/2"	23/64"	4-7/8"	17/32"	6"	45/64"	6"	7/8"	6"
1/32"	1-3/8"	13/64"	3-5/8"	3/8"	5"	35/64"	6"	23/32"	6"	57/64"	6"
3/64"	1-3/4"	7/32"	3-3/4"	25/64"	5-1/8"	9/16"	6"	47/64"	6"	29/32"	6"
1/16"	1-7/8"	15/64"	3-7/8"	13/32"	5-1/4"	37/64"	6"	3/4"	6"	59/64"	6"
5/64"	2"	1/4"	4"	27/64"	5-3/8"	19/32"	6"	49/64"	6"	15/16"	6"
3/32"	2-1/4"	17/64"	4-1/8"	7/16"	5-1/2"	39/64"	6"	25/32"	6"	61/64"	6"
7/64"	2-5/8"	9/32"	4-1/4"	29/64"	5-5/8"	5/8"	6"	51/64"	6"	31/32"	6"
1/8"	2-3/4"	19/64"	4-3/8"	15/32"	5-3/4"	41/64"	6"	13/16"	6"	63/64"	6"
9/64"	2-7/8"	5/16"	4-1/2"	31/64"	5-7/8"	21/32"	6"	53/64"	6"	1"	6"
5/32"	3-1/8"	21/64"	4-5/8"	1/2"	6"	43/64"	6"	27/32"	6"		
11/64"	3-1/4"	11/32"	4-3/4"	33/64"	6"	11/16"	6"	55/64"	6"		

## STC179-1A, HSS DRILL BLANK, JOBBER LENGTH

High Speed Steel, Hardness: HRC63-66.

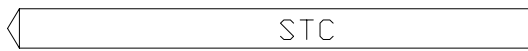

Tolerance Limits

0" - 0.250"	+0.0000" - 0.0005"
0.251" - 0.3906"	+0.0000" - 0.0009"
0.3910" - 1.000"	+0.0000" - 0.0010"

### WIRE GAUGE SIZES

Size	Overall Length	Size	Overall Length	Size	Overall Length	Size	Overall Length	Size	Overall Length	Size	Overall Length
1	3-7/8"	15	3-3/8"	29	2-7/8"	43	2-1/4"	57	1-3/4"	71	1-1/4"
2	3-7/8"	16	3-3/8"	30	2-3/4"	44	2-1/8"	58	1-5/8"	72	1-1/8"
3	3-3/4"	17	3-3/8"	31	2-3/4"	45	2-1/8"	59	1-5/8"	73	1-1/8"
4	3-3/4"	18	3-1/4"	32	2-3/4"	46	2-1/8"	60	1-5/8"	74	1"
5	3-3/4"	19	3-1/4"	33	2-5/8"	47	2"	61	1-5/8"	75	1"
6	3-3/4"	20	3-1/4"	34	2-5/8"	48	2"	62	1-1/2"	76	7/8"
7	3-5/8"	21	3-1/4"	35	2-5/8"	49	2"	63	1-1/2"	77	7/8"
8	3-5/8"	22	3-1/8"	36	2-1/2"	50	2"	64	1-1/2"	78	7/8"
9	3-5/8"	23	3-1/8"	37	2-1/2"	51	2"	65	1-1/2"	79	3/4"
10	3-5/8"	24	3-1/8"	38	2-1/2"	52	1-7/8"	66	1-3/8"	80	3/4"
11	3-1/2"	25	3"	39	2-3/8"	53	1-7/8"	67	1-3/8"		
12	3-1/2"	26	3"	40	2-3/8"	54	1-7/8"	68	1-3/8"		
13	3-1/2"	27	3"	41	2-3/8"	55	1-7/8"	69	1-3/8"		
14	3-3/8"	28	2-7/8"	42	2-1/4"	56	1-3/4"	70	1-1/4"		

### LETTER SIZES

Size	Overall Length	Size	Overall Length	Size	Overall Length	Size	Overall Length	Size	Overall Length	Size	Overall Length
A	3-7/8"	F	4-1/8"	K	4-1/4"	O	4-1/2"	S	4-7/8"	W	5-1/8"
B	4"	G	4-1/8"	L	4-1/4"	P	4-5/8"	T	4-7/8"	X	5-1/8"
C	4"	H	4-1/8"	M	4-3/8"	Q	4-3/4"	U	5"	Y	5-1/4"
D	4"	I	4-1/8"	N	4-3/8"	R	4-3/4"	V	5"	Z	5-1/4"
E	4"	J	4-1/8"								

## STC269, ANNULAR HOLE CUTTER ( MAGNETIC DRILL)

Material: HSS or Carbide Tipped.

Shank Diameter: 3/4". ( 19mm)

Please specify Material & Depth of drilling when ordering.

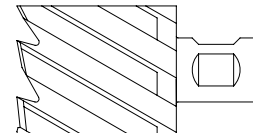
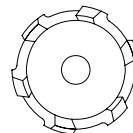

DIAMETER OF CUT, METRIC SIZES							
DRILLING DEPTH: 30MM, 50MM, 75MM, 100MM							
12	23	35	47	59	71	83	95
13	24	36	48	60	72	84	96
13	25	37	49	61	73	85	97
14	26	38	50	62	74	86	98
15	27	39	51	63	75	87	99
16	28	40	52	64	76	88	100
17	29	41	53	65	77	89	
18	30	42	54	66	78	90	
19	31	43	55	67	79	91	
20	32	44	56	68	80	92	
21	33	45	57	69	81	93	
22	34	46	58	70	82	94	

DIAMETER OF CUT, INCH SIZES			
DRILLING DEPTH: 1", 2", 3", 4"			
1/2"	1-1/4"	2"	3"
9/16"	1-5/16"	2-1/16"	3-1/8"
5/8"	1-3/8"	2-1/8"	3-1/4"
11/16"	1-7/16"	2-1/4"	3-3/8"
3/4"	1-1/2"	2-5/16"	3-1/2"
13/16"	1-9/16"	2-3/8"	3-5/8"
7/8"	1-5/8"	2-1/2"	3-3/4"
15/16"	1-11/16"	2-9/16"	3-7/8"
1"	1-3/4"	2-5/8"	4"
1-1/16"	1-13/16"	2-11/16"	
1-1/8"	1-7/8"	2-3/4"	
1-3/16"	1-15/16"	2-7/8"	

## STC028M, HSS TAPER SHANK TWIST DRILL, Metric Series

DIN345, GOST10903

NOTE.: Standard delivery with 118° point,

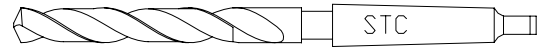

Size	Flute Length	Overall Length	Morse Taper
6.00	57	138	1
6.20	63	144	1
6.50	63	144	1
6.80	69	150	1
7.00	69	150	1
7.20	69	150	1
7.50	69	150	1
7.80	75	156	1
8.00	75	156	1
8.20	75	156	1
8.50	75	156	1
8.80	81	162	1
9.00	81	162	1
9.20	81	162	1
9.50	81	162	1
9.80	87	168	1
10.00	87	168	1
10.20	87	168	1
10.50	87	168	1
10.80	94	175	1
11.00	94	175	1
11.20	94	175	1
11.50	94	175	1
11.80	94	175	1
12.00	101	182	1
12.20	101	182	1
12.50	101	182	1
12.80	101	182	1
13.00	101	182	1
13.20	101	182	1
13.50	108	189	1
13.80	108	189	1
14.00	108	189	1
14.25	114	212	2
14.50	114	212	2
14.75	114	212	2
15.00	114	212	2
15.25	120	218	2
15.50	120	218	2
15.75	120	218	2
16.00	120	218	2
16.25	125	223	2
16.50	125	223	2
16.75	125	223	2
17.00	125	223	2
17.25	130	228	2
17.50	130	228	2
17.75	130	228	2
18.00	130	228	2
18.25	135	233	2
18.50	135	233	2
18.75	135	233	2
19.00	135	233	2
19.25	140	238	2
19.50	140	238	2
19.75	140	238	2

Size	Flute Length	Overall Length	Morse Taper
20.00	140	238	2
20.25	145	243	2
20.50	145	243	2
20.75	145	243	2
21.00	145	243	2
21.25	150	248	2
21.50	150	248	2
21.75	150	248	2
22.00	150	248	2
22.25	150	248	2
22.50	155	253	2
22.75	155	253	2
23.00	155	253	2
23.25	155	276	3
23.50	155	276	3
23.75	160	281	3
24.00	160	281	3
24.25	160	281	3
24.50	160	281	3
24.75	160	281	3
25.00	160	281	3
25.25	165	286	3
25.50	165	286	3
25.75	165	286	3
26.00	165	286	3
26.25	165	286	3
26.50	165	286	3
26.75	170	291	3
27.00	170	291	3
27.25	170	291	3
27.50	170	291	3
27.75	170	291	3
28.00	170	291	3
28.25	175	296	3
28.50	175	296	3
28.75	175	296	3
29.00	175	296	3
29.25	175	296	3
29.50	175	296	3
29.75	175	296	3
30.00	175	296	3
30.25	180	301	3
30.50	180	301	3
30.75	180	301	3
31.00	180	301	3
31.25	180	301	3
31.50	180	301	3
31.75	185	306	3
32.00	185	334	4
32.50	185	334	4
33.00	185	334	4
33.50	185	334	4
34.00	190	339	4
34.50	190	339	4
35.00	190	339	4
35.50	190	339	4

Size	Flute Length	Overall Length	Morse Taper
36.00	195	344	4
36.50	195	344	4
37.00	195	344	4
37.50	195	344	4
38.00	200	349	4
38.50	200	349	4
39.00	200	349	4
39.50	200	349	4
40.00	200	349	4
40.50	205	354	4
41.00	205	354	4
41.50	205	354	4
42.00	205	354	4
42.50	205	354	4
43.00	210	359	4
43.50	210	359	4
44.00	210	359	4
44.50	210	359	4
45.00	210	359	4
45.50	215	364	4
46.00	215	364	4
46.50	215	364	4
47.00	215	364	4
47.50	215	364	4
48.00	220	369	4
48.50	220	369	4
49.00	220	369	4
49.50	220	369	4
50.00	220	369	4
50.50	225	374	4
51.00	225	412	5
52.00	225	412	5
53.00	225	412	5
54.00	230	417	5
55.00	230	417	5
56.00	230	417	5
57.00	235	422	5
58.00	235	422	5
59.00	235	422	5
60.00	235	422	5
61.00	240	427	5
62.00	240	427	5
63.00	240	427	5
64.00	245	432	5
65.00	245	432	5
66.00	245	432	5
67.00	245	432	5
68.00	250	437	5
69.00	250	437	5
70.00	250	437	5
71.00	250	437	5
72.00	255	442	5
73.00	255	442	5
74.00	255	442	5
75.00	255	442	5
76.00	260	447	5

## STC028M, HSS TAPER SHANK TWIST DRILL, Metric Series

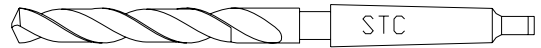

DIN345, GOST10903

Size	Flute Length	Overall Length	Morse Taper
77.0	260	514	6
78.0	260	514	6
79.0	260	514	6
80.0	260	514	6
81.0	265	519	6
82.0	265	519	6
83.0	265	519	6
84.0	265	519	6

Size	Flute Length	Overall Length	Morse Taper
85.0	265	519	6
86.0	270	524	6
87.0	270	524	6
88.0	270	524	6
89.0	270	524	6
90.0	270	524	6
91.0	275	529	6
92.0	275	529	6

Size	Flute Length	Overall Length	Morse Taper
93.0	275	529	6
94.0	275	529	6
95.0	275	529	6
96.0	280	534	6
97.0	280	534	6
98.0	280	534	6
99.0	280	534	6
100.0	280	534	6

## STC028, TAPER SHANK TWIST DRILL, Inch Series

NOTE.: Standard delivery with 118° point,  
ANSI / ASME B94.11M-1993

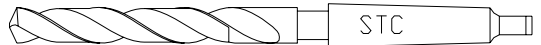

Size	Flute Length	Overall Length	Morse Taper
1/4"	2-7/8"	6-1/8"	MT1
17/64"	3"	6-1/4"	MT1
9/32"	3"	6-1/4"	MT1
19/64"	3-1/8"	6-3/8"	MT1
5/16"	3-1/8"	6-3/8"	MT1
21/64"	3-1/4"	6-1/2"	MT1
11/32"	3-1/4"	6-1/2"	MT1
23/64"	3-1/2"	6-3/4"	MT1
3/8"	3-1/2"	6-3/4"	MT1
25/64"	3-5/8"	7"	MT1
13/32"	3-5/8"	7"	MT1
27/64"	3-7/8"	7-1/4"	MT1
7/16"	3-7/8"	7-1/4"	MT1
29/64"	4-1/8"	7-1/2"	MT1
15/32"	4-1/8"	7-1/2"	MT1
31/64"	4-3/8"	8-1/8"	MT2
1/2"	4-3/8"	8-1/8"	MT2
33/64"	4-5/8"	8-1/2"	MT2
17/32"	4-5/8"	8-1/2"	MT2
35/64"	4-7/8"	8-3/4"	MT2
9/16"	4-7/8"	8-3/4"	MT2
37/64"	4-7/8"	8-3/4"	MT2
19/32"	4-7/8"	8-3/4"	MT2
39/64"	4-7/8"	8-3/4"	MT2
5/8"	4-7/8"	8-3/4"	MT2
41/64"	5-1/8"	9"	MT2
21/32"	5-1/8"	9"	MT2
43/64"	5-3/8"	9-1/4"	MT2
11/16"	5-3/8"	9-1/4"	MT2
45/64"	5-5/8"	9-1/2"	MT2
23/32"	5-5/8"	9-1/2"	MT2
47/64"	5-7/8"	9-3/4"	MT2
3/4"	5-7/8"	9-3/4"	MT2
49/64"	6"	9-7/8"	MT2
25/32"	6"	9-7/8"	MT2
51/64"	6-1/8"	10-3/4"	MT3
13/16"	6-1/8"	10-3/4"	MT3
53/64"	6-1/8"	10-3/4"	MT3
27/32"	6-1/8"	10-3/4"	MT3
55/64"	6-1/8"	10-3/4"	MT3
7/8"	6-1/8"	10-3/4"	MT3
57/64"	6-1/8"	10-3/4"	MT3

Size	Flute Length	Overall Length	Morse Taper
29/64"	6-1/8"	10-3/4"	MT3
59/64"	6-1/8"	10-3/4"	MT3
15/16"	6-1/8"	10-3/4"	MT3
61/64"	6-3/8"	11"	MT3
31/32"	6-3/8"	11"	MT3
63/64"	6-3/8"	11"	MT3
1"	6-3/8"	11"	MT3
1-1/64"	6-1/2"	11-1/8"	MT3
1-1/32"	6-1/2"	11-1/8"	MT3
1-3/64"	6-5/8"	11-1/4"	MT3
1-1/16"	6-5/8"	11-1/4"	MT3
1-5/64"	6-7/8"	12-1/2"	MT4
1-3/32"	6-7/8"	12-1/2"	MT4
1-7/64"	7-1/8"	12-1/2"	MT4
1-1/8"	7-1/8"	12-1/2"	MT4
1-9/64"	7-1/4"	12-7/8"	MT4
1-5/32"	7-1/4"	12-7/8"	MT4
1-11/64"	7-3/8"	13"	MT4
1-3/16"	7-3/8"	13"	MT4
1-13/64"	7-1/2"	13-1/8"	MT4
1-7/32"	7-1/2"	13-1/8"	MT4
1-15/64"	7-7/8"	13-1/2"	MT4
1-1/4"	7-7/8"	13-1/2"	MT4
1-17/64"	8-1/2"	14-1/8"	MT4
1-9/32"	8-1/2"	14-1/8"	MT4
1-19/64"	8-5/8"	14-1/4"	MT4
1-5/16"	8-5/8"	14-1/4"	MT4
1-21/64"	8-3/4"	14-3/8"	MT4
1-11/32"	8-3/4"	14-3/8"	MT4
1-23/64"	8-7/8"	14-1/2"	MT4
1-3/8"	8-7/8"	14-1/2"	MT4
1-25/64"	9"	14-5/8"	MT4
1-13/32"	9"	14-5/8"	MT4
1-27/64"	9-1/8"	14-3/4"	MT4
1-7/16"	9-1/8"	14-3/4"	MT4
1-29/64"	9-1/4"	14-7/8"	MT4
1-15/16"	9-1/4"	14-7/8"	MT4
1-31/64"	9-3/8"	15"	MT4
1-1/2"	9-3/8"	15"	MT4
1-33/64"	9-3/4"	15"	MT4
1-17/32"	9-3/8"	16-3/8"	MT5
1-35/64"	9-5/8"	15-1/4"	MT4

Size	Flute Length	Overall Length	Morse Taper
1-9/16"	9-5/8"	16-5/8"	MT5
1-37/64"	9-7/8"	15-1/2"	MT4
1-19/32"	9-7/8"	16-7/8"	MT5
1-39/64"	10"	15-5/8"	MT4
1-5/8"	10"	17"	MT5
1-41/64"	10-1/8"	15-3/4"	MT4
1-21/32"	10-1/8"	17-1/8"	MT5
1-11/16"	10-1/8"	17-1/8"	MT5
1-23/32"	10-1/8"	17-1/8"	MT5
1-47/64"	10-3/8"	16-1/4"	MT4
1-3/4"	10-1/8"	17-1/8"	MT5
1-25/32"	10-1/8"	17-1/8"	MT5
1-13/16"	10-1/8"	17-1/8"	MT5
1-27/32"	10-1/8"	17-1/8"	MT5
1-7/8"	10-3/8"	17-3/8"	MT5
1-29/32"	10-3/8"	17-3/8"	MT5
1-15/16"	10-3/8"	17-3/8"	MT5
1-31/32"	10-3/8"	17-3/8"	MT5
2"	10-3/8"	17-3/8"	MT5
2-1/32"	10-3/8"	17-3/8"	MT5
2-1/16"	10-1/4"	17-3/8"	MT5
2-3/32"	10-1/4"	17-3/8"	MT5
2-1/8"	10-1/4"	17-3/8"	MT5
2-5/32"	10-1/4"	17-3/8"	MT5
2-3/16"	10-1/4"	17-3/8"	MT5
2-7/32"	10-1/8"	17-3/8"	MT5
2-1/4"	10-1/8"	17-3/8"	MT5
2-5/16"	10-1/8"	17-3/8"	MT5
2-3/8"	10-1/8"	17-3/8"	MT5
2-7/16"	11-1/4"	18-3/4"	MT5
2-1/2"	11-1/4"	18-3/4"	MT5
2-9/16"	11-7/8"	19-1/2"	MT5
2-5/8"	11-7/8"	19-1/2"	MT5
2-11/16"	12-3/4"	20-3/8"	MT5
2-3/4"	12-3/4"	20-3/8"	MT5
2-13/16"	13-3/8"	21-1/8"	MT5
2-7/8"	13-3/8"	21-1/8"	MT5
2-15/16"	14"	21-3/4"	MT5
3"	14"	21-3/4"	MT5
3-1/8"	14-5/8"	24-1/2"	MT6
3-1/4"	15-1/2"	25-1/2"	MT6
3-1/2"	16-1/4"	24"	MT5

## STC028ML, HSS TAPER SHANK TWIST DRILL, Long Series

DIN341, GOST12121.

NOTE.: Standard delivery with 118° point,

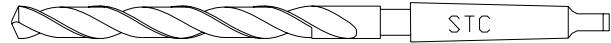

Size	Flute Length	Overall Length	Morse Taper
6.0	80	161	1
6.2	86	167	1
6.5	86	167	1
6.8	93	174	1
7.0	93	174	1
7.2	93	174	1
7.5	93	174	1
7.8	100	181	1
8.0	100	181	1
8.2	100	181	1
8.5	100	181	1
8.8	107	188	1
9.0	107	188	1
9.2	107	188	1
9.5	107	188	1
9.8	116	197	1
10.0	116	197	1
10.2	116	197	1
10.5	116	197	1
10.8	125	206	1
11.0	125	206	1
11.2	125	206	1
11.5	125	206	1
11.8	125	206	1
12.0	134	215	1
12.2	134	215	1
12.5	134	215	1
12.8	134	215	1
13.0	134	215	1
13.2	134	215	1
13.5	142	223	1
13.8	142	223	1
14.0	142	223	1
14.25	147	245	2
14.50	147	245	2
14.75	147	245	2
15.00	147	245	2
15.25	153	251	2
15.50	153	251	2
15.75	153	251	2
16.00	153	251	2
16.25	159	257	2
16.50	159	257	2
16.75	159	257	2
17.00	159	257	2
17.25	165	263	2
17.50	165	263	2

Size	Flute Length	Overall Length	Morse Taper
17.75	165	263	2
18.00	165	263	2
18.25	171	269	2
18.50	171	269	2
18.75	171	269	2
19.00	171	269	2
19.25	177	275	2
19.50	177	275	2
19.75	177	275	2
20.00	177	275	2
20.25	184	282	2
20.50	184	282	2
20.75	184	282	2
21.00	184	282	2
21.25	191	289	2
21.50	191	289	2
21.75	191	289	2
22.00	191	289	2
22.25	191	289	2
22.50	198	296	2
22.75	198	296	2
23.00	198	296	2
23.25	198	319	3
23.50	198	319	3
23.75	206	327	3
24.00	206	327	3
24.25	206	327	3
24.50	206	327	3
24.75	206	327	3
25.00	206	327	3
25.25	214	335	3
25.50	214	335	3
25.75	214	335	3
26.00	214	335	3
26.25	214	335	3
26.50	214	335	3
26.75	222	343	3
27.00	222	343	3
27.25	222	343	3
27.50	222	343	3
27.75	222	343	3
28.00	222	343	3
28.25	230	351	3
28.50	230	351	3
28.75	230	351	3
29.00	230	351	3
29.25	230	351	3

Size	Flute Length	Overall Length	Morse Taper
29.5	230	351	3
29.75	230	351	3
30	230	351	3
30.25	239	360	3
30.5	239	360	3
30.75	239	360	3
31	239	360	3
31.25	239	360	3
31.5	239	360	3
31.75	248	369	3
32	248	397	4
32.5	248	397	4
33	248	397	4
33.5	248	397	4
34	257	406	4
34.5	257	406	4
35	257	406	4
35.5	257	406	4
36	267	416	4
36.5	267	416	4
37	267	416	4
37.5	267	416	4
38	277	426	4
38.5	277	426	4
39	277	426	4
39.5	277	426	4
40	277	426	4
40.5	287	436	4
41	287	436	4
41.5	287	436	4
42	287	436	4
42.5	287	436	4
43	298	447	4
43.5	298	447	4
44	298	447	4
44.5	298	447	4
45	298	447	4
45.5	310	459	4
46	310	459	4
46.5	310	459	4
47	310	459	4
47.5	310	459	4
48	321	470	4
48.5	321	470	4
49	321	470	4
49.5	321	470	4
50	321	470	4

## STC028L, HSS TAPER SHANK LENGTHENED TWIST DRILL,

AS PER GOST 2092-77, GB/T1438.3-1996

NOTE.: Standard delivery with 118° point,



Size	Flute Length	Overall Length	Morse Taper
6.0	145	225	1
6.2	150	230	1
6.5	150	230	1
6.8	155	235	1
7.0	155	235	1
7.2	155	235	1
7.5	155	235	1
7.8	160	240	1
8.0	160	240	1
8.2	160	240	1
8.5	160	240	1
8.8	165	245	1
9.0	165	245	1
9.2	165	245	1
9.5	165	245	1
9.8	170	250	1
10.0	170	250	1
10.2	170	250	1
10.5	170	250	1
10.8	175	255	1
11.0	175	255	1
11.2	175	255	1
11.5	175	255	1
11.8	175	255	1
12.0	180	260	1
12.2	180	260	1
12.5	180	260	1
12.8	180	260	1
13.0	180	260	1
13.2	180	260	1
13.5	185	265	1
13.8	185	265	1
14.0	185	265	1

Size	Flute Length	Overall Length	Morse Taper
14.25	190	290	2
14.50	190	290	2
14.75	190	290	2
15.00	190	290	2
15.25	195	295	2
15.50	195	295	2
15.75	195	295	2
16.00	195	295	2
16.25	200	300	2
16.50	200	300	2
16.75	200	300	2
17.00	200	300	2
17.25	205	305	2
17.50	205	305	2
17.75	205	305	2
18.00	205	305	2
18.25	210	310	2
18.50	210	310	2
18.75	210	310	2
19.00	210	310	2
19.25	220	320	2
19.50	220	320	2
19.75	220	320	2
20.00	220	320	2
20.25	230	330	2
20.50	230	330	2
20.75	230	330	2
21.00	230	330	2
21.25	235	335	2
21.50	235	335	2
21.75	235	335	2
22.00	235	335	2
22.25	235	335	2

Size	Flute Length	Overall Length	Morse Taper
22.50	240	340	2
22.75	240	340	2
23.00	240	340	2
23.25	240	360	3
23.50	240	360	3
23.75	245	365	3
24.00	245	365	3
24.25	245	365	3
24.50	245	365	3
24.75	245	365	3
25.00	245	365	3
25.25	255	375	3
25.50	255	375	3
25.75	255	375	3
26.00	255	375	3
26.25	255	375	3
26.50	255	375	3
26.75	265	385	3
27.00	265	385	3
27.25	265	385	3
27.50	265	385	3
27.75	265	385	3
28.00	265	385	3
28.25	275	395	3
28.50	275	395	3
28.75	275	395	3
29.00	275	395	3
29.25	275	395	3
29.5	275	395	3
29.75	275	395	3
30	275	395	3

## STC030-4, 1/4" REDUCED SHANK TWIST DRILL, Jobber Length

Standard delivery with 118° point  
Jobber Length.



Size	Flute Length	Overall Length
17/64"	2-7/8"	4-1/8"
9/32"	2-15/16"	4-1/4"
19/64"	3-1/16"	4-3/8"
5/16"	3-3/16"	4-1/2"

Size	Flute Length	Overall Length
21/64"	3-5/16"	4-5/8"
11/32"	3-7/16"	4-3/4"
23/64"	3-1/2"	4-7/8"
3/8"	3-5/8"	5"

Size	Flute Length	Overall Length
25/64"	3-3/4"	5-1/8"
13/32"	3-7/8"	5-1/4"
27/64"	3-15/16"	5-3/8"
7/16"	4-1/16"	5-1/2"

Size	Flute Length	Overall Length
29/64"	4-3/16"	5-5/8"
15/32"	4-5/16"	5-3/4"
31/64"	4-3/8"	5-7/8"
1/2"	4-1/2"	6"

## STC030-3, 1/2" REDUCED SHANK TWIST DRILL, Jobber Length

Standard delivery with 118° point  
Jobber Length.

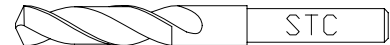

Size	Flute Length	Overall Length
25/64"	3-3/4"	5-1/8"
13/32"	3-7/8"	5-1/4"
27/64"	3-15/16"	5-3/8"
7/16"	4-1/16"	5-1/2"

Size	Flute Length	Overall Length
29/64"	4-3/16"	5-5/8"
15/32"	4-5/16"	5-3/4"
31/64"	4-3/8"	5-7/8"
1/2"	4-1/2"	6"

Size	Flute Length	Overall Length
33/64"	4-13/16"	6-5/8"
17/32"	4-13/16"	6-5/8"
35/64"	4-13/16"	6-5/8"
9/16"	4-13/16"	6-5/8"

Size	Flute Length	Overall Length
37/64"	5-3/16"	7-1/8"
19/32"	5-3/16"	7-1/8"
39/64"	5-3/16"	7-1/8"
5/8"	5-3/16"	7-1/8"

## STC030-2, 1/2" SHANK SILVER & DEMING DRILL

Standard delivery with 118° point  
Overall Length: 6", Flute Length: 3".

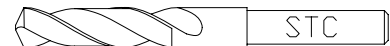

Size	Flute Length	Overall Length
33/64"	3"	6"
17/32"	3"	6"
35/64"	3"	6"
9/16"	3"	6"
37/64"	3"	6"
19/32"	3"	6"
39/64"	3"	6"
5/8"	3"	6"
41/64"	3"	6"
21/32"	3"	6"
43/64"	3"	6"
11/16"	3"	6"
45/64"	3"	6"
23/32"	3"	6"
47/64"	3"	6"
3/4"	3"	6"

Size	Flute Length	Overall Length
49/64"	3"	6"
25/32"	3"	6"
51/64"	3"	6"
13/16"	3"	6"
53/64"	3"	6"
27/32"	3"	6"
55/64"	3"	6"
7/8"	3"	6"
57/64"	3"	6"
29/64"	3"	6"
59/64"	3"	6"
15/16"	3"	6"
61/64"	3"	6"
31/32"	3"	6"
63/64"	3"	6"
1"	3"	6"

Size	Flute Length	Overall Length
1-1/64"	3"	6"
1-1/32"	3"	6"
1-3/64"	3"	6"
1-1/16"	3"	6"
1-5/64"	3"	6"
1-3/32"	3"	6"
1-7/64"	3"	6"
1-1/8"	3"	6"
1-9/64"	3"	6"
1-5/32"	3"	6"
1-11/64"	3"	6"
1-3/16"	3"	6"
1-13/64"	3"	6"
1-7/32"	3"	6"
1-15/64"	3"	6"
1-1/4"	3"	6"

Size	Flute Length	Overall Length
1-17/64"	3"	6"
1-9/32"	3"	6"
1-19/64"	3"	6"
1-5/16"	3"	6"
1-21/64"	3"	6"
1-11/32"	3"	6"
1-23/64"	3"	6"
1-3/8"	3"	6"
1-25/64"	3"	6"
1-13/32"	3"	6"
1-27/64"	3"	6"
1-7/16"	3"	6"
1-29/64"	3"	6"
1-15/32"	3"	6"
1-31/64"	3"	6"
1-1/2"	3"	6"

## STC030-2, 3/4" SHANK SILVER & DEMING DRILL

Standard delivery with 118° point  
Overall Length: 6", Flute Length: 3".

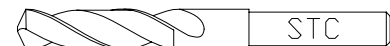

Size	Flute Length	Overall Length
1"	3"	6"
1-1/32"	3"	6"
1-1/16"	3"	6"
1-3/32"	3"	6"
1-1/8"	3"	6"
1-5/32"	3"	6"

Size	Flute Length	Overall Length
1-3/16"	3"	6"
1-7/32"	3"	6"
1-1/4"	3"	6"
1-9/32"	3"	6"
1-5/16"	3"	6"
1-11/32"	3"	6"

Size	Flute Length	Overall Length
1-3/8"	3"	6"
1-7/16"	3"	6"
1-1/2"	3"	6"
1-9/16"	3"	6"
1-5/8"	3"	6"
1-11/16"	3"	6"

Size	Flute Length	Overall Length
1-3/4"	3"	6"
1-13/16"	3"	6"
1-7/8"	3"	6"
1-15/16"	3"	6"
2"	3"	6"

## STC025-1, SOLID CARBIDE DRILL, Inch



### FRACTIONAL SIZE

Size	Flute Length	Overall Length
1/32"	3/8"	1-1/8"
3/64"	3/4"	1-1/2"
1/16"	3/4"	1-1/2"
5/64"	7/8"	1-3/4"
3/32"	1"	2"
7/64"	1-1/4"	2-1/4"
1/8"	1-1/4"	2-1/4"
9/64"	1-3/8"	2-1/2"
5/32"	1-3/8"	2-1/2"
11/64"	1-5/8"	2-3/4"
3/16"	1-5/8"	2-3/4"
13/64"	1-3/4"	3"
7/32"	1-3/4"	3"
15/64"	2"	3-1/4"
1/4"	2"	3-1/4"
17/64"	2-1/8"	3-1/2"

Size	Flute Length	Overall Length
9/32"	2-1/8"	3-1/2"
19/64"	2-3/8"	3-3/4"
5/16"	2-3/8"	3-3/4"
21/64"	2-1/2"	4"
11/32"	2-1/2"	4"
23/64"	2-1/2"	4"
3/8"	2-3/4"	4-1/4"
25/64"	2-7/8"	4-1/2"
13/32"	2-7/8"	4-1/2"
27/64"	2-7/8"	4-1/2"
7/16"	2-7/8"	4-1/2"
29/64"	3"	4-3/4"
15/32"	3"	4-3/4"
31/64"	3"	4-3/4"
1/2"	3"	4-3/4"

### LETTER SIZE

Size	Flute Length	Overall Length
A	2"	3-1/4"
B	2"	3-1/4"
C	2"	3-1/4"
D	2"	3-1/4"
E	2"	3-1/4"
F	2"	3-1/4"
G	2-1/8"	3-1/2"
H	2-1/8"	3-1/2"
I	2-1/8"	3-1/2"
J	2-1/8"	3-1/2"
K	2-1/8"	3-1/2"
L	2-1/8"	3-1/2"
M	2-3/8"	3-3/4"

Size	Flute Length	Overall Length
N	2-3/8"	3-3/4"
O	2-3/8"	3-3/4"
P	2-3/8"	3-3/4"
Q	2-1/2"	4"
R	2-1/2"	4"
S	2-1/2"	4"
T	2-1/2"	4"
U	2-3/4"	4-1/4"
V	2-3/4"	4-1/4"
W	2-3/4"	4-1/4"
X	2-3/4"	4-1/4"
Y	2-3/4"	4-1/4"
Z	2-3/4"	4-1/4"

### WIRE GAUGE SIZE

Size	Flute Length	Overall Length
1	1-3/4"	3"
2	1-3/4"	3"
3	1-3/4"	3"
4	1-3/4"	3"
5	1-3/4"	3"
6	1-3/4"	3"
7	1-3/4"	3"
8	1-3/4"	3"
9	1-3/4"	3"
10	1-5/8"	2-3/4"
11	1-5/8"	2-3/4"
12	1-5/8"	2-3/4"
13	1-5/8"	2-3/4"
14	1-5/8"	2-3/4"
15	1-5/8"	2-3/4"
16	1-5/8"	2-3/4"
17	1-5/8"	2-3/4"
18	1-5/8"	2-3/4"
19	1-5/8"	2-3/4"
20	1-3/8"	2-1/2"

Size	Flute Length	Overall Length
21	1-3/8"	2-1/2"
22	1-3/8"	2-1/2"
23	1-3/8"	2-1/2"
24	1-3/8"	2-1/2"
25	1-3/8"	2-1/2"
26	1-3/8"	2-1/2"
27	1-3/8"	2-1/2"
28	1-3/8"	2-1/2"
29	1-3/8"	2-1/2"
30	1-1/4"	2-1/4"
31	1-1/4"	2-1/4"
32	1-1/4"	2-1/4"
33	1-1/4"	2-1/4"
34	1-1/4"	2-1/4"
35	1-1/4"	2-1/4"
36	1-1/4"	2-1/4"
37	1-1/4"	2-1/4"
38	1-1/4"	2-1/4"
39	1-1/4"	2-1/4"
40	1"	2"

### WIRE GAUGE SIZE,

Size	Flute Length	Overall Length
41	1"	2"
42	1"	2"
43	1"	2"
44	1"	2"
45	7/8"	1-3/4"
46	7/8"	1-3/4"
47	7/8"	1-3/4"
48	7/8"	1-3/4"
49	7/8"	1-3/4"
50	7/8"	1-3/4"

Size	Flute Length	Overall Length
51	3/4"	1-1/2"
52	3/4"	1-1/2"
53	3/4"	1-1/2"
54	3/4"	1-1/2"
55	3/4"	1-1/2"
56	3/4"	1-1/2"
57	3/4"	1-1/2"
58	3/4"	1-1/2"
59	3/4"	1-1/2"
60	3/4"	1-1/2"

## STC025-2, SOLID CARBIDE DRILL, Metric

### METRIC SIZES, GOST 17275, MIDDLE SERIES

Size	Flute Length	Overall Length
3	24	55
3.2	24	55
3.5	28	60
3.8	30	63
4	30	63
4.2	30	63
4.5	32	65
4.8	36	70
5	36	70
5.2	36	70
5.5	40	75
5.8	40	75
6	40	75
6.2	42	80
6.5	42	80
6.8	45	85
7	45	85
7.2	45	85
7.5	45	85

Size	Flute Length	Overall Length
7.8	52	95
8	52	95
8.2	52	95
8.5	52	95
8.8	55	100
9	55	100
9.2	55	100
9.5	60	105
9.8	60	105
10	60	105
10.2	60	105
10.5	60	105
10.8	65	110
11	65	110
11.2	65	110
11.5	65	110
11.8	65	110
12	70	120

### GOST 17274, SHORT SERIES

Size	Flute Length	Overall Length
1	6	32
1.2	8	32
1.5	9	36
1.8	11	38
2	12	38
2.2	13	40
2.5	14	42
2.8	16	45
3	16	45
3.2	18	50
3.5	20	52
3.8	22	55
4	22	55
4.2	22	55
4.5	24	60
4.8	26	63
5	26	63
5.2	26	63
5.5	28	65
5.8	28	65
6	28	65
6.2	30	70
6.5	30	70

Size	Flute Length	Overall Length
6.8	34	75
7	34	75
7.2	34	75
7.5	34	75
7.8	38	80
8	38	80
8.2	38	80
8.5	38	80
8.8	40	85
9	40	85
9.2	40	85
9.5	40	85
9.8	45	90
10	45	90
10.2	45	90
10.5	45	90
10.8	48	95
11	48	95
11.2	48	95
11.5	48	95
11.8	48	95
12	50	100

## STC026-1, CARBIDE TIPPED DRILL, Straight Shank, Inch



### FRACTIONAL SIZE

Size	Flute Length	Overall Length
1/8"	1-5/8"	2-3/4"
9/64"	1-3/4"	2-7/8"
5/32"	2"	3-1/8"
11/64"	2-1/8"	3-1/4"
3/16"	2-5/16"	3-1/2"
13/64"	2-7/16"	3-5/8"
7/32"	2-1/2"	3-3/4"
15/64"	2-5/8"	3-7/8"
1/4"	2-3/4"	4"
17/64"	2-7/8"	4-1/8"
9/32"	2-15/16"	4-1/4"
19/64"	3-1/16"	4-3/8"
5/16"	3-3/16"	4-1/2"

### LETTER SIZE

Size	Flute Length	Overall Length
A	2-5/8"	3-7/8"
B	2-3/4"	4"
C	2-3/4"	4"
D	2-3/4"	4"
E	2-3/4"	4"
F	2-7/8"	4-1/8"
G	2-7/8"	4-1/8"
H	2-7/8"	4-1/8"
I	2-7/8"	4-1/8"
J	2-7/8"	4-1/8"
K	2-15/16"	4-1/4"
L	2-15/16"	4-1/4"
M	3-1/16"	4-3/8"

### WIRE GAUGE SIZE

Size	Flute Length	Overall Length
1	2-5/8"	3-7/8"
2	2-5/8"	3-7/8"
3	2-1/2"	3-3/4"
4	2-1/2"	3-3/4"
5	2-1/2"	3-3/4"
6	2-1/2"	3-3/4"
7	2-7/16"	3-5/8"
8	2-7/16"	3-5/8"
9	2-7/16"	3-5/8"
10	2-7/16"	3-5/8"
11	2-5/16"	3-1/2"
12	2-5/16"	3-1/2"
13	2-5/16"	3-1/2"
14	2-3/16"	3-3/8"
15	2-3/16"	3-3/8"
16	2-3/16"	3-3/8"

Size	Flute Length	Overall Length
21/64"	3-5/16"	4-5/8"
11/32"	3-7/16"	4-3/4"
23/64"	3-1/2"	4-7/8"
3/8"	3-5/8"	5"
25/64"	3-3/4"	5-1/8"
13/32"	3-7/8"	5-1/4"
27/64"	3-15/16"	5-3/8"
7/16"	4-1/16"	5-1/2"
29/64"	4-3/16"	5-5/8"
15/32"	4-5/16"	5-3/4"
31/64"	4-3/8"	5-7/8"
1/2"	4-1/2"	6"

## STC026-2, CARBIDE TIPPED DRILL, Straight Shank, Metric Sizes



### DIN8037,

Size	Flute Length	Overall Length
5	28	63
5.5	32	71
6	32	71
6.5	32	71
7	40	80
7.5	40	80
8	40	80
8.5	50	90
9	50	90
9.5	50	90

Size	Flute Length	Overall Length
10	56	100
10.5	56	100
11	56	100
11.5	63	112
12	63	112
12.5	63	112
13	63	112
14	71	125
15	71	125
16	80	140

### GOST 22735, SHORT TYPE

Size	Flute Length	Overall Length
5	36	70
5.5	40	75
6	40	75
6.5	42	80
7	45	85
7.5	45	85
8	52	95
8.5	52	95
9	55	100
9.5	55	100

Size	Flute Length	Overall Length
10	60	105
10.5	60	105
11	65	110
11.5	65	110
12	70	120
12.5	70	120
13	70	120
14	70	122
15	75	130
16	80	138

### GOST 22735, LONG TYPE

Size	Flute Length	Overall Length
5	86	52
5.5	57	93
6	57	93
6.5	63	101
7	69	109
7.5	69	109
8	75	117
8.5	75	117
9	81	125
9.5	81	125

Size	Flute Length	Overall Length
10	87	133
10.5	87	133
11	94	142
11.5	94	142
12	101	151
12.5	101	151
13	101	151
14	108	160
15	114	169
16	120	178

## STC026-3, CARBIDE TIPPED DRILL, Taper Shank

DIN8041, GOST22736-77

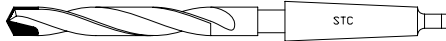

Size	SHORT TYPE		LONG TYPE		Morse Taper
	Flute Length	Overall Length	Flute Length	Overall Length	
10	60	140	87	168	1
10.2	60	140	87	168	1
10.5	60	140	87	168	1
10.8	65	145	94	175	1
11	65	145	94	175	1
11.2	65	145	94	175	1
11.5	65	145	94	175	1
11.8	65	145	94	175	1
12	70	170	101	199	2
12.5	70	170	101	199	2
12.8	70	170	101	199	2
13	70	170	101	199	2
13.5	70	170	108	206	2
13.8	70	170	108	206	2
14	70	170	108	206	2
14.5	75	175	114	212	2
15	75	175	114	212	2
15.5	80	180	120	218	2
16	80	180	120	218	2
16.5	85	185	125	223	2
17	85	185	125	223	2
17.5	90	190	130	228	2
18	90	190	130	228	2
18.5	95	215	135	256	3
19	95	215	135	256	3
19.5	100	220	140	261	3
20	100	220	140	261	3
20.5	105	225	145	266	3
21	105	225	145	266	3
21.5	110	230	150	271	3
22	110	230	150	271	3
22.5	110	230	155	276	3
23	110	230	155	276	3
23.5	110	230	155	276	3
24	115	235	160	281	3
24.5	115	235	160	281	3
25	115	235	160	281	3
25.5	115	235	165	286	3
26	115	235	165	286	3
26.5	115	235	165	286	3
27	120	240	170	291	3
27.5	120	270	170	319	4
28	120	270	170	319	4
28.5	125	275	175	324	4
29	125	275	175	324	4
29.5	125	275	175	324	4
30	125	275	175	324	4

## STC018-2, HSS STRAIGHT SHANK CORE DRILLS

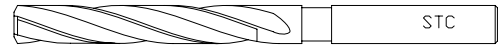

ASME B94.11M-1993

Size	Flute Length	Overall Length	Size	Flute Length	Overall Length
1/4"	3-3/4"	6-1/8"	21/32"	5-1/8"	9"
9/32"	3-7/8"	6-1/4"	11/16"	5-3/8"	9-1/4"
5/16"	4"	6-3/8"	23/32"	5-3/8"	9-1/2"
11/32"	4-1/8"	6-1/2"	3/4"	5-7/8"	9-3/4"
3/8"	4-1/4"	6-3/4"	25/32"	6"	9-7/8"
13/32"	4-3/8"	7"	13/16"	6-1/8"	10"
7/16"	4-5/8"	7-1/4"	27/32"	6-1/8"	10"
15/32"	4-3/4"	7-1/2"	7/8"	6-1/8"	10"
1/2"	4-3/4"	7-3/4"	29/32"	6-1/8"	10"
17/32"	4-3/4"	8"	15/16"	6-1/8"	1-3/4"
9/16"	4-7/8"	8-1/4"	31/32"	6-3/8"	11"
19/32"	4-7/8"	8-3/4"	1"	6-3/8"	11"
5/8"	4-7/8"	8-3/4"			

## STC018-2M, HSS STRAIGHT SHANK CORE DRILLS.



DIN344, H8

Size	Flute Length	Overall Length	Size	Flute Length	Overall Length
5	52	86	13	101	151
5.8	57	93	13.75	108	160
6	57	93	14	108	160
6.8	69	107	14.75	114	169
7	69	107	15	114	169
7.8	75	117	15.75	120	178
8	75	117	16	120	178
8.8	81	125	16.75	125	184
9	81	125	17.00	125	184
9.8	87	133	17.75	130	191
10	87	133	18	130	191
10.75	94	142	18.7	135	198
11	94	142	19	135	198
11.75	101	151	19.7	140	205
12	101	151	20	140	205
12.75	101	151			

## STC018-1, HSS TAPER SHANK CORE DRILLS, Inch Size

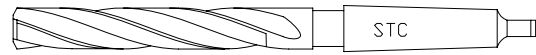

ANSI/ASME B94.11M-1993

Size	Flute Length	Overall Length	Morse Taper	Size	Flute Length	Overall Length	Morse Taper	Size	Flute Length	Overall Length	Morse Taper
1/2"	4-3/8"	8-1/4"	2	1-3/32"	6-7/8"	12-1/4"	4	1-11/16"	10-1/8"	17-1/8"	5
17/32"	4-5/8"	8-1/2"	2	1-1/8"	7-1/8"	12-3/4"	4	1-23/32"	10-1/8"	17-1/8"	5
9/16"	4-7/8"	8-3/4"	2	1-5/32"	7-1/4"	12-7/8"	4	1-3/4"	10-1/8"	17-1/8"	5
19/32"	4-7/8"	8-3/4"	2	1-3/16"	7-3/8"	13"	4	1-25/32"	10-1/8"	17-1/8"	5
5/8"	4-7/8"	8-3/4"	2	1-7/32"	7-1/2"	13-1/8"	4	1-13/16"	10-1/8"	17-1/8"	5
21/32"	5-1/8"	9"	2	1-1/4"	7-7/8"	13-1/2"	4	1-27/32"	10-1/8"	17-1/8"	5
11/16"	5-3/8"	9-1/4"	2	1-9/32"	8-1/2"	14-1/8"	4	1-7/8"	10-3/8"	17-3/8"	5
23/32"	5-5/8"	9-1/2"	2	1-5/16"	8-5/8"	14-1/4"	4	1-29/32"	10-3/8"	17-3/8"	5
3/4"	5-7/8"	9-3/4"	2	1-11/32"	8-3/4"	14-3/8"	4	1-15/16"	10-3/8"	17-3/8"	5
25/32"	6"	9-7/8"	3	1-3/8"	8-7/8"	14-1/2"	4	1-31/32"	10-3/8"	17-3/8"	5
13/16"	6-1/8"	10-3/4"	3	1-13/32"	9"	14-5/8"	4	2"	10-3/8"	17-3/8"	5
27/32"	6-1/8"	10-3/4"	3	1-7/16"	9-1/8"	14-3/4"	4	2-1/8"	10-1/4"	17-3/8"	5
7/8"	6-1/8"	10-3/4"	3	1-15/32"	9-1/4"	14-7/8"	4	2-1/4"	10-1/8"	17-3/8"	5
29/32"	6-1/8"	10-3/4"	3	1-1/2"	9-3/8"	15"	4	2-3/8"	10-1/8"	18-3/4"	5
15/16"	6-1/8"	10-3/4"	3	1-17/32"	9-3/8"	16-3/8"	5	2-1/2"	11-1/4"	19-1/2"	5
31/32"	6-3/8"	11"	3	1-9/16"	9-5/8"	16-5/8"	5	2-5/8"	11-7/8"	19-1/2"	5
1"	6-3/8"	11"	3	1-19/32"	9-7/8"	16-7/8"	5	2-3/4"	12-3/4"	20-3/8"	5
1-1/32"	6-1/2"	11-1/8"	3	1-5/8"	10"	17"	5	2-7/8"	13-3/8"	21-1/8"	5
1-1/16"	6-5/8"	11-1/4"	3	1-21/32"	10-1/8"	17-1/8"	5	3"	14"	21-3/4"	5

## STC018-1M, HSS TAPER SHANK CORE DRILLS. Metric

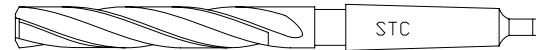

DIN343, H8

Size	Flute Length	Overall Length	Morse Taper	Size	Flute Length	Overall Length	Morse Taper	Size	Flute Length	Overall Length	Morse Taper
8	75	156	1	19	135	233	2	34	190	339	4
9	81	162	1	20	140	238	2	35	190	339	4
10	87	168	1	21	145	243	2	36	195	344	4
11	94	175	1	22	150	248	2	38	200	349	4
12	101	182	1	23	155	253	2	40	200	349	4
13	101	182	1	24	160	281	3	42	205	354	4
14	108	189	1	25	160	281	3	44	210	359	4
15	114	212	2	26	165	286	3	45	210	359	4
16	120	218	2	28	170	291	3	46	215	364	4
17	125	223	2	30	175	296	3	48	220	369	4
18	130	228	2	32	185	334	4	50	220	369	4

## STC027B, SUBLAND TWIST DRILL



STC027B1, 90° Subland drill with parallel shank, DIN8374

Major Diameter	Minor Diameter	Overall Length	Flute Length	Step Length	Screw Size
6	3.2	93	57	9	M3
8	4.3	117	75	11	M4
10	5.3	133	87	13	M5
11.5	6.4	142	94	15	M6
15	8.4	169	114	19	M8
19	10.5	198	135	23	M10

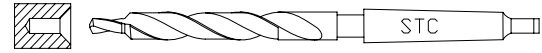

STC027B2, 90° Subland drill with taper shank, DIN8375

Major Diameter	Minor Diameter	Overall Length	Flute Length	Step Length	Screw Size	Morse Taper
11	5.5	175	94	13	M5	1
13	6.6	182	101	15	M6	1
17.2	9	228	130	19	M8	2
21.5	11	248	150	23	M10	2



STC027B3 180° Subland drill with parallel shank, DIN8376

Major Diameter	Minor Diameter	Overall Length	Flute Length	Step Length	Screw Size
6	3.4	93	57	9	M3
8	4.5	117	75	11	M4
10	5.5	133	87	13	M5
11	6.6	142	94	15	M6
15	9	169	114	19	M8
18	11	191	130	23	M10



STC027B4 180° Subland drill with taper shank, DIN8377

Major Diameter	Minor Diameter	Overall Length	Flute Length	Step Length	Screw Size	Morse Taper
10	5.5	168	87	13	M5	1
11	6.6	175	94	15	M6	1
15	9	212	114	19	M8	2
18	11	228	130	23	M10	2
20	14	238	140	27	M12	3
24	16	281	160	31	M14	3
26	18	286	165	35	M16	3
30	20	296	175	39	M18	3
33	22	334	185	43	M20	3



STC027A1 DRILL & COUNTERBORING CAP SCREW

Major Diameter	Minor Diameter	Overall Length	Flute Length	Step Length	Screw Size
7/32"	0.136	3-3/4"	2-1/2"	3/8"	NO.4
0.228	0.141	3-7/8"	2-5/8"	3/8"	NO.5
1/4"	0.15	4"	2-3/4"	1/2"	NO.6
L	0.178	4-1/4"	2-15/16"	1/2"	NO.8
Q	0.204	4-3/4"	3-7/16"	5/8"	NO.10
13/32"	9/32"	5-1/4"	3-7/8"	11/16"	1/4"
1/2"	11/32"	6"	4-1/2"	3/4"	5/16"
19/32"	13/32"	7-1/8"	5-3/16"	7/8"	3/8"
11/16"	15/32"	7-5/8"	5-5/8"	1"	7/16"
25/32"	17/32"	5-1/8"	3-1/4"	1"	1/2"
31/32"	21/32"	5-7/8"	3-7/8"	1"	5/8"



STC027A3 DRILL 45° CHAMFERED HOLE TO BE TAPPED

Major Diameter	Minor Diameter	Overall Length	Flute Length	Step Length	Screw Size
0.1285"	0.089"	2-3/4"	1-5/8"	3/8"	4-40
9/64"	0.101"	2-7/8"	1-3/4"	1/2"	5-40
5/32"	0.109"	3-1/8"	2"	1/2"	6-32
3/16"	0.136"	3-1/2"	2-15/16"	1/2"	8-32
3/16"	0.136"	3-1/2"	2-15/16"	1/2"	8-36
1/4"	0.152"	4"	2-3/4"	5/8"	10-24
1/4"	0.161"	4"	2-3/4"	5/8"	10-32
9/32"	0.179"	4-1/4"	2-15/16"	11/16"	12-24
21/64"	0.204"	4-5/8"	3-5/16"	13/16"	1/4-20
21/64"	0.218"	4-5/8"	3-5/16"	13/16"	1/4-28
13/32"	0.261"	5-1/4"	3-7/8"	15/16"	5/16-18
13/32"	0.272"	5-1/4"	3-7/8"	15/16"	5/16-24
31/64"	0.316"	5-7/8"	4-3/8"	1"	3/8-16
31/64"	0.339"	5-7/8"	4-3/8"	1"	3/8-24
17/32"	0.375"	6-5/8"	4-13/16"	1-1/16"	7/16-14
17/32"	0.390"	6-5/8"	4-13/16"	1-1/16"	7/16-20
5/8"	0.437"	7-1/8"	5-3/16"	1-1/16"	1/2-13
5/8"	0.452"	7-1/8"	5-3/16"	1-1/16"	1/2-20
3/4"	0.531"	7-5/8"	5-5/8"	1-1/16"	5/8-11



STC027A2 DRILL & COUNTERBORING 82° FLAT HEAD

Major Diameter	Minor Diameter	Overall Length	Flute Length	Step Length	Screw Size
15/64"	0.116"	3-7/8"	2-5/8"	3/8"	NO.4
F"	0.128"	4-1/8"	2-7/8"	3/8"	NO.5
9/32"	0.142"	4-1/4"	2-15/16"	1/2"	NO.6
Q	0.169"	4-3/4"	3-7/16"	1/2"	NO.8
W	0.196"	5-1/8"	3-3/4"	5/8"	NO.10
1/2"	0.257"	6"	4-1/2"	11/16"	1/4"
5/8"	0.320"	7-1/8"	5-3/16"	3/4"	5/16"
3/4"	0.383"	7-5/8"	5-5/8"	7/8"	3/8"
13/16"	0.446"	5-1/4"	3-3/8"	1"	7/16"
7/8"	0.510"	5-1/2"	3-1/2"	1"	1/2"

## STC036-1, INCH SIZE COMBINED DRILLS & COUNTERSINKS ( CENTER DRILL )

ANSI / ASME B94.11 M-1993  
PLAIN TYPE, 60° Angle, Ground



Size	Body Diameter	Drill Diameter	Overall Length
0	1/8"	1/32"	1-1/8"
1	1/8"	3/64"	1-1/4"
2	3/16"	5/64"	1-7/8"
3	1/4"	7/64"	2"
4	5/16"	1/8"	2-1/8"
4-1/2	3/8"	9/64"	2-1/2"
5	7/16"	3/16"	2-3/4"
6	1/2"	7/32"	3"
7	5/8"	1/4"	3-1/4"
8	3/4"	5/16"	3-1/2"
9	7/8"	11/32"	3-5/8"
10	1"	3/8"	3-3/4"

## STC036-M, METRIC SIZE CENTER DRILL

DIN333, GOST14952

FROM R, R TYPE, 60° Angle



Milled / Ground

Size	Body Diameter	Overall Length
0.5	3.15	25
0.8	3.15	25
1	3.15	31.5
1.25	3.15	31.5
1.6	4	35.5
2	5	40
2.5	6.3	45

Size	Body Diameter	Overall Length
3.15	8	50
4	10	56
5	12.5	63
6.3	16	71
8	20	80
10	25	100
12.5	31.5	125

FROM A, PLAIN TYPE, 60° Angle

BELL TYPE, 60° / 120° Angle, Milled / Ground

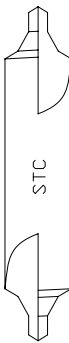

Size	Body Diameter	Drill Diameter	Overall Length
11	1/8"	3/64"	1-1/4"
12	3/16"	1/16"	1-7/8"
13	1/4"	3/32"	2"
14	5/16"	7/64"	2-1/8"
15	7/16"	5/32"	2-3/4"
16	1/2"	3/16"	3"
17	5/8"	7/32"	3-1/4"
18	3/4"	1/4"	3-1/2"
19	7/8"	5/16"	3-5/8"
20	1"	3/8"	3-3/4"

Milled / Ground

Size	Body Diameter	Overall Length
0.5	3.15	25
0.8	3.15	25
1	3.15	31.5
1.25	3.15	31.5
1.6	4	35.5
2	5	40
2.5	6.3	45

Size	Body Diameter	Overall Length
3.15	8	50
4	10	56
5	12.5	63
6.3	16	71
8	20	80
10	25	100
12.5	31.5	125

FROM B, PLAIN TYPE, 60° & 120° Angle

## STC037, INCH SIZE COMBINED DRILLS & COUNTERSINKS, Long Series

PLAIN TYPE.  
60° Angle



Size	Body Diameter	Drill Diameter	Overall Length
1A	1/8"	3/64"	3"
1B	1/8"	3/64"	4"
1C	1/8"	3/64"	5"
1D	1/8"	3/64"	6"
2A	3/16"	5/64"	3"
2B	3/16"	5/64"	4"
2C	3/16"	5/64"	5"
2D	3/16"	5/64"	6"
3A	1/4"	7/64"	3"
3B	1/4"	7/64"	4"
3C	1/4"	7/64"	5"
3D	1/4"	7/64"	6"
4A	5/16"	1/8"	3"
4B	5/16"	1/8"	4"
4C	5/16"	1/8"	5"
4D	5/16"	1/8"	6"
5B	7/16"	3/16"	4"
5C	7/16"	3/16"	5"
5D	7/16"	3/16"	6"
6B	1/2"	7/32"	4"
6C	1/2"	7/32"	5"
6D	1/2"	7/32"	6"
7	5/8"	1/4"	6"
8	3/4"	5/16"	6"

## STC037-M, METRIC SIZE CENTER DRILLS, Long Series, Form A

FORM A, PLAIN TYPE, 60° Angle



Milled / Ground

Size	Body Diameter	Overall Length
1	4	35.5
1.25	5	40
1.6	6.3	45
2	8	50
2.5	10	56
3.15	11.2	60

Size	Body Diameter	Overall Length
4	14	67
5	16	75
6.3	20	80
8	25	100
10	31.5	125

Milled / Ground

Size	Body Diameter	Overall Length
0.75	3.5	60
1	4	60
1.5	5	60
2	6	80
2.5	8	80

Size	Body Diameter	Overall Length
3	8	80
3	10	100
4	10	100
4	12	100

## STC039, THREE FLUTES COUNTERSINKS, Straight Shank



DIN335C, 90° Angle.

60°, 82°, 120° Point Angle available also.

Size	Shank Diameter	Overall Length
4.3	4	40
5	4	40
5.3	4	40
6	5	45
6.3	5	45
7	6	50
7.3	6	50
8	6	50
8.3	6	50
9.4	6	50
10	6	50

Size	Shank Diameter	Overall Length
10.4	6	50
11.5	8	56
12.4	8	56
13.4	8	56
15	10	60
16.5	10	60
19	10	63
20.5	10	63
23	10	67
25	10	67
31	12	71

## STC041, THREE FLUTES COUNTERSINKS, Taper Shank



Included Angle: 60°, 90°, 120°

Size	Morse Taper	Overall Length
15	1	85
16.5	1	85
19	2	100
20.5	2	100
23	2	106
25	2	106
26	2	106
28	2	112
30	2	112

Size	Morse Taper	Overall Length
31	2	112
34	2	117
37	2	118
40	3	140
50	3	150
63	4	180
80	4	190
100	4	200

## STC042, SINGLE FLUTE COUNTERSINK, Straight Shank,

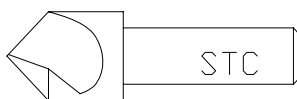

Included Angle: 82°

Max cut diameter	Shank Diameter	Overall Length
3/16"	3/16"	1-1/2"
1/4"	1/4"	2"
5/16"	1/4"	2"
3/8"	1/4"	2"
1/2"	1/4"	2"
5/8"	1/2"	2-1/4"

Max cut diameter	Shank Diameter	Overall Length
3/4"	1/2"	2-3/4"
7/8"	1/2"	2-3/4"
1"	1/2"	2-3/4"
1-1/4"	3/4"	3"
1-1/2"	3/4"	3-1/2"
2"	3/4"	3-3/4"

## STC042, THREE-FLUTE CENTER REAMER, Straight Shank, American Style

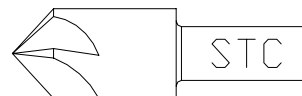

Included Angle: 60°, 82°, 90°, 100°

Max cut diameter	Shank Diameter	Overall Length
1/4"	1/4"	1-1/2"
3/8"	1/4"	1-3/4"
1/2"	3/8"	2"
5/8"	3/8"	2-1/4"

Max cut diameter	Shank Diameter	Overall Length
3/4"	1/2"	2-5/8"
1"	1/2"	2-3/4"
1-1/4"	3/4"	3"
1-1/2"	3/4"	3"

## STC042, 5-FLUTE COUNTERSINK, Straight Shank, American Style

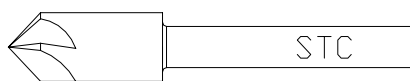

Included Angle: 60°, 82°, 90°, 100°

Max cut diameter	Shank Diameter	Overall Length
1/2"	1/2"	3-7/8"
5/8"	1/2"	4"
3/4"	1/2"	4-1/8"
7/8"	1/2"	4-1/4"

Max cut diameter	Shank Diameter	Overall Length
1"	1/2"	4-3/8"
1-1/4"	1/2"	5"
1-1/2"	1/2"	5-3/8"

## STC044, HSS 6-FLUTE CHATTERLESS COUNTERSINK,

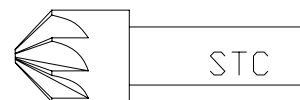

Included Angle: 60°, 82°, 90°, 100°

Max cut diameter	Shank Diameter	Overall Length
3/16"	3/16"	1-1/2"
1/4"	1/4"	2"
5/16"	1/4"	2"
3/8"	1/4"	2"
1/2"	1/4"	2"
5/8"	1/2"	2-3/4"

Max cut diameter	Shank Diameter	Overall Length
3/4"	1/2"	2-3/4"
7/8"	1/2"	2-3/4"
1"	1/2"	2-3/4"
1-1/4"	3/4"	3-3/8"
1-1/2"	3/4"	3-1/2"
2"	1"	4-3/8"

## STC045, METRIC HSS COUNTERSINKS & DEBURRING TOOLS,

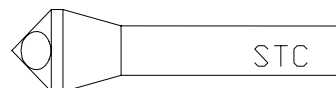

Included Angle: 90°. Material: HSS, HSS-E

Cutting Range	Shank Diameter	Overall Length
2 - 5	6	45
5 - 10	6	50
10 - 15	10	65
15 - 20	12	85
20 - 25	15	105

Cutting Range	Shank Diameter	Overall Length
25 - 30	15	115
30 - 35	15	125
35 - 40	18	135
40 - 50	18	165

Taper Shank Countersinks & Deburring tools Available also.

## STC046, HSS SOLID CAP SCREW COUNTERBORE, DIN373

3-Flute, Material: HSS, HSS-E.

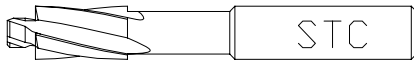

Screw Size	Cutting Diameter	Pilot Diameter	Shank Diameter	Total Length	Flute Number
1	2.2	0.75	2.2	45	2
1.2	2.5	0.95	2.5	45	2
1.4	2.8	1.1	2.8	45	2
1.6	3.3	1.25	3.3	56	2
1.8	3.8	1.45	3.8	56	2
2	4.3	1.6	4.3	56	2
2.5	5	2.05	5	56	2
3	6	2.5	5	71	3
3.5	6.5	2.9	5	71	3
4	8	3.3	5	71	3
4.5	9	3.7	8	80	3
5	10	4.2	8	80	3
6	11	5	8	80	3
7	13	6	12.5	100	3
8	15	6.8	12.5	100	3
9	16	7.8	12.5	100	3
10	18	8.5	12.5	100	3
12	20	10.2	12.5	100	3

## STC044-M, COUNTERSINKS, Straight Shank

GB/T 4258-2004, GOST 14953-80

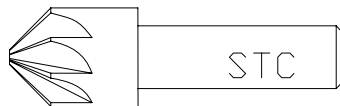

Included Angle: 60°, 90°, 120°

Size	Small End Diameter	Shank Diameter	Size	Small End Diameter	Shank Diameter
8	1.6	8	16	3.2	10
10	2	8	20	4	10
12.5	2.5	8	25	7	10

## STC044-MT, COUNTERSINKS, Taper Shank

GB/T 1143-2004, GOST 14953-80



Included Angle: 60°, 90°, 120°

Size	Small End Diameter	M.T. Shank	Size	Small End Diameter	M.T. Shank
16	3.2	1	40	12.5	3
20	4	2	50	16	3
25	7	2	63	20	4
31.5	9	2	80	25	4

## STC001, HSS STEPS DRILL

Material: HSS.

Bright Finishing or Tin-coated.

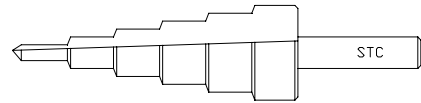

### STC001A, INCH SIZES STEPS DRILL

No. of Holes	Description	Shank Diameter	Step Thickness
13	1/8" - 1/2" by 1/32" increase	1/4"	1/8"
6	3/16" - 1/2" by 1/16" increase	1/4"	3/8"
9	1/4" - 3/4" by 1/16" increase	3/8"	1/8"
12	3/16" - 7/8" by 1/16" increase	3/8"	1/8"
10	1/4" - 1.3/8" by 1/8" increase	1/2"	1/8"

### STC001A, INCH SIZES STEPS DRILL

No. of Holes	Description	Shank Diameter
9	4 - 12mm by 1mm Increase	6/6.5mm
5	4 - 12mm by 2mm Increase	6/6.5mm
7	6 - 18mm by 2mm Increase	10mm
8	6 - 20mm by 2mm Increase	8mm
12	6 - 30mm by 2/3mm Increase	10mm
9	4 - 20mm by 2mm Increase	10mm
10	4 - 22mm by 2mm Increase	10mm
14	4 - 30mm by 2 mm increase	14mm
13	5 - 35mm by 2/3mm Increase	13mm

## STC001-S, STEPS DRILL SET

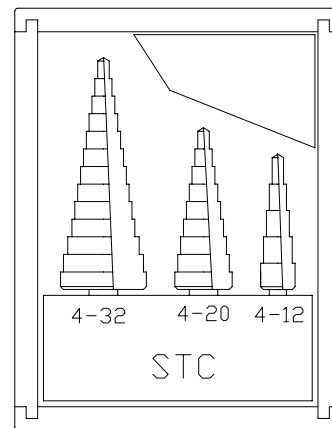

Model	pcs/set	DESCRIPTION	PACKING
STC001-S1	3pcs/set	4 - 12 x 9	Metal / wood / plastic
		4 - 20 x 9	
		4 - 30 x 14	
STC001-S2	3pcs/set	4 - 12 x 5	Metal / wood / plastic
		4 - 32 x 15	
STC001-S3	3pcs/set	4 - 12 x 9	Metal / wood / plastic
		6 - 20 x 8 6 - 30 x 13	
STC001-S4	3pcs/set	3/16" - 1/2" x 6 1/8" - 1/2" x 13 1/4" - 3/4" x 9	Metal / wood / plastic

## STC009, HSS TWIST DRILL SET

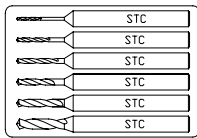

**STC009-1, 6Pcs Mini Drill Set**  
 6pcs HSS Straight Shank Mini Drill Set  
 Shank: 2.38mm, Length Total: 38mm  
 Packed in Plastic Bag  
 0.6 / 0.8 / 1.0 / 1.2 / 1.5 / 2.0mm

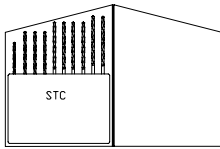

**STC009-2, 20pcs HSS Mini Drill Set, Inch**  
 #1-80# x 20pcs HSS Mini Drill Set  
 Straight Shank, Jobber Length.  
 Packed in Metal Box  
 No. 61, 62, 63, 64, 65, 66, 67, 68, 69, 70,  
 71, 72, 73, 74, 75, 76, 77, 78, 79, 80.

**STC009-3, 20pcs Mini Drill Set, Metric**  
 20pcs HSS Parallel Shank Mini Drill Set  
 0.3-1.6mm x 20pcs, Jobber Length  
 Packed in Plastic Box  
 0.3 / 0.35 / 0.4 / 0.45 / 0.5 / 0.55 / 0.6  
 0.65 / 0.7 / 0.75 / 0.8 / 0.85 / 0.9 / 0.95  
 1.0 / 1.2 / 1.3 / 1.4 / 1.5 / 1.6mm

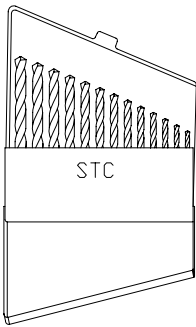

**STC009-4-3, 13Pcs Drill Set, Metric**  
 1/16"-1/4" x 13pcs HSS Twist Drill Set  
 Straight Shank, Jobber Length  
 Packed in Metal / Plastic Box  
 1/16", 5/64", 3/32", 7/64", 1/8", 9/64", 5/32"  
 11/64", 3/16", 13/64" 7/32", 15/64", 1/4"

**STC009-4-1, 13Pcs Drill Set, Inch**  
 1.5-6.5mm x 13pcs HSS Twist Drill Set.  
 Parallel Shank, Jobber Length.  
 Packed in Metal / Plastic Box  
 1.5 / 2.0 / 2.5 / 3.0 / 3.2 / 3.5 / 4.0 / 4.5  
 4.8 / 5.0 / 5.5 / 6.0 / 6.5mm

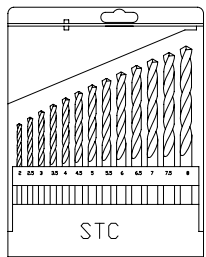

**STC009-4-2, 13Pcs Drill Set, Metric**  
 2-8mm x 13pcs HSS Twist Drill Set  
 Parallel Shank, Jobber Length.  
 Packed in Plastic Box  
 2.0 / 2.5 / 3.0 / 3.5 / 4.0 / 4.5 / 5.0 / 5.5  
 6.0 / 6.5 / 7.0 / 7.5 / 8.0mm

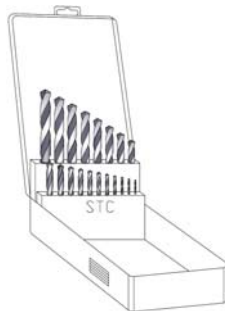

**STC009-5, 19Pcs Drill Set**  
 1-19mm x 19pcs HSS Twist Drill Set  
 Parallel Shank, Jobber Length  
 Packed in Metal Box / Plastic Box  
 1.0 / 1.5 / 2.0 / 2.5 / 3.0 / 3.5 / 4.0 / 4.5 / 5.0  
 5.5 / 6.0 / 6.5 / 7.0 / 7.5 / 8.0 / 8.5 / 9.0 / 9.5  
 10.0 mm

**STC009-6, 21Pcs Drill, Set**  
 1/16"-3/8" x 21pcs HSS Twist Drill Set  
 Straight Shank, Jobber Length  
 Packed in Metal Box / Plastic Box  
 1/16", 5/64", 3/32", 7/64", 1/8", 9/64", 5/32"  
 11/64", 3/16", 13/64" 7/32", 15/64", 1/4",  
 17/64", 9/32", 19/64", 5/16", 21/64", 11/32"  
 23/64", 3/8"

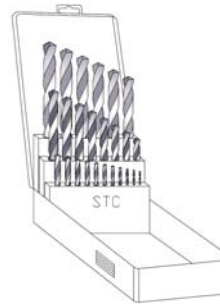

**STC009-7, 25Pcs Drill Set,**  
 Bright Finishing, Tin-Coated, Black Oxide  
 1-13mm x 25pcs HSS Twist Drill Set  
 Parallel Shank, Jobber Length  
 Packed in Metal Box  
 1.0 / 1.5 / 2.0 / 2.5 / 3.0 / 3.5 / 4.0 / 4.5 / 5.0  
 5.5 / 6.0 / 6.5 / 7.0 / 7.5 / 8.0 / 8.5 / 9.0 / 9.5  
 10 / 10.5 / 11 / 11.5 / 12 / 12.5 / 13mm

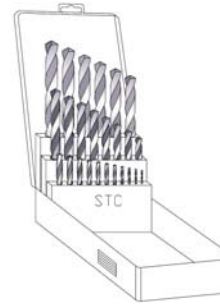

**STC009-8, 29Pcs Drill Set**  
 1/16"-1/2" x 29pcs HSS Twsit Drill Set  
 Straight Shank, Jobber Length  
 Packed in Metal Box  
 1/16", 5/64", 3/32", 7/64", 1/8", 9/64", 5/32"  
 11/64", 3/16", 13/64" 7/32", 15/64", 1/4",  
 17/64", 9/32", 19/64", 5/16", 21/64", 11/32"  
 23/64", 3/8", 25/64", 13/32", 27/64", 7/16"  
 29/64", 15/32", 31/64", 1/2"

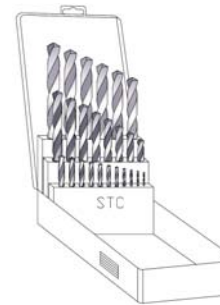

**STC-9-15, 26Pcs Drill Set**  
 A - Z x 26pcs HSS Twist Drill Set  
 Straight Shank, Jobber Length  
 Packed in Metal Box  
 Letter Size: From A to Z.

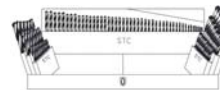

**STC009-9, 60Pcs Drill Set**  
 No. 1 - 60 x 60pcs HSS Twist Drill Set.  
 Straight Shank, Jobber Length  
 Packed in Metal Box  
 Wire Gauge size: No.1 to No. 60.

**STC009-12, 115Pcs Drill Set**  
 115pcs HSS Twist Drill Set  
 Straight Shank, Jobber Length  
 Packed in Metal Box / Blow Case  
 Fractional Size: 1/16"-1/2" x 29pcs  
 Wire Gauge Size: No. 1 - No.60 x 60pcs  
 Letter Size: A - Z x 26pcs

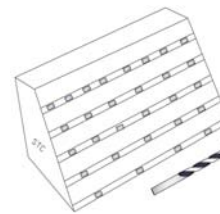

**STC010-2, 385pcs HSS Twist Drill Set**  
 Parallel Shank, Jobber Length  
 Packed in Metal Display Case.

Size	Qty.:	Size	Qty.:	Size	Qty.:
1.0	50	5.0	20	9.5	3
1.5	50	5.5	10	10.0	3
2.0	30	6.0	10	10.25	3
2.5	20	6.5	10	10.5	3
3.0	20	6.8	10	11.0	3
3.3	20	7.0	10	11.5	3
3.5	20	7.5	5	12.0	3
4.0	20	8.0	5	12.5	3
4.5	20	8.5	5	13.0	3
4.8	20	9.0	3		

## STC009, HSS TWIST DRILL SET

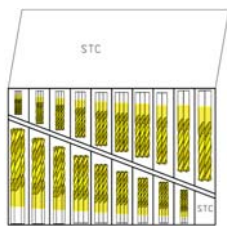

STC010-3, 170pcs HSS Twist Drill Set

Parallel Shank, Jobber Length  
Packed in Metal Case.

Size	Qty.:	Size	Qty.:	Size	Qty.:
1.0	10	4.5	10	8.0	10
1.5	10	5.0	10	8.5	5
2.0	10	5.5	10	9.0	5
2.5	10	6.0	10	9.5	5
3.0	10	6.5	10	10.0	5
3.5	10	7.0	10		
4.0	10	7.5	10		

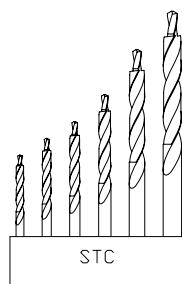

STC027A1-S, 6pcs Cap Screw Drill Set

6pcs Cap Screw Drill Set.  
For Drilling & Counterboring Cap Screw Clearance Holes. HSS, Jobber Length, Packed in Wooden Case  
No.6, No.8, No.10, 1/4", 5/16", 3/8"

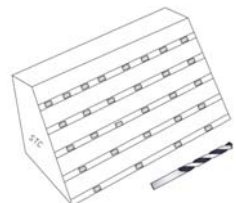

STC010-1, 2035pcs HSS Twist Drill Set

Parallel Shank, Jobber Length  
Packed in Metal Case.

Size	Qty.:	Size	Qty.:	Size	Qty.:
0.5	100	4.0	150	7.5	40
1.0	100	4.5	120	8.0	40
1.5	300	5.0	90	8.5	35
2.0	200	5.5	70	9.0	35
2.5	200	6.0	55	9.5	30
3.0	150	6.5	50	10.0	30
3.5	200	7.0	40		

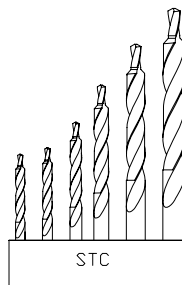

STC027A2-S, 6Pcs Flat Head Screw Drill Set

6pcs Flat Head Screw Drill Set.  
For Drilling & Counterboring 82° Flat Screw Clearance Holes. HSS, Jobber Length, Packed in Wooden Case  
No.6, No.8, No.10, 1/4", 5/16", 3/8"

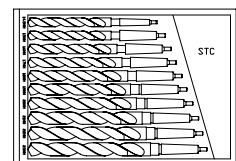

STC029-S1, 10Pcs Taper Shank Drill Set.

10pcs Taper Shank Twist Drill Set  
HSS, Jobber Length  
Packed in Wooden Case  
MT1: 14.5mm  
MT2: 15/ 16/ 17/18/ 19/ 20/ 21/ 22/ 23mm

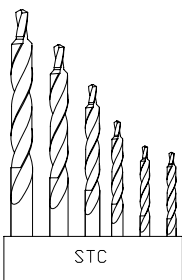

STC027A3-S, 45° Chamfered Hole Drill Set

For Drilling 45° Chamfered Holes to be Tapped. HSS, Jobber Length  
Packed in Wooden Case  
No.6-32, No.8-32, No.10-24, 1/4"-20, 5/16"-18, 3/8"-16.

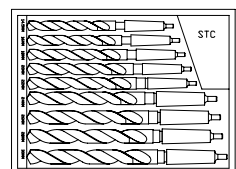

STC029-S2, 9Pcs Taper Shank Drill Set

9pcs Taper Shank Twist Drill Set  
HSS, Jobber Length  
Packed in Wooden Case  
MT2: 14.5 / 16 / 18 / 20 / 22mm  
MT3: 24 / 26 / 28 30mm

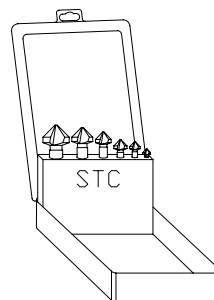

STC040-1, 6Pcs 90° Countersink Set

6pcs Countersink Set.  
90° Tool Point. DIN335C. HSS  
Packed in Metal Box / Plastic Box.  
6.3 / 8.3 / 10.4 / 12.4 / 16.5 / 20.5mm

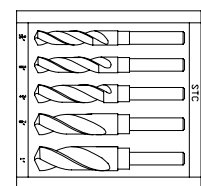

STC030-3SA, 5Pcs 1/2" Shank Drill Set

5pcs/set Silver & Deming Drill, 1/2" Shank  
HSS, 1/2" Shank, 6" Overall Length  
Packed in Wooden Case  
9/16", 5/8", 3/4" 7/8", 1"

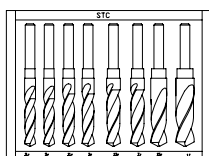

STC030-2SC, 8Pcs 1/2" Shank Drill Set

8pcs/set Silver & Deming Drill 1/2" Shank  
HSS, 1/2" Shank, 6" Overall Length  
Packed in Wooden Case  
9/16", 5/8", 11/16", 3/4", 13/16", 7/8", 15/16", 1"

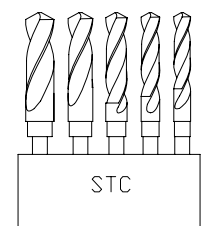

STC030-1S, 5Pcs 3/4" Shank Drill Set

5pcs Silver & Deming Drill, 3/4" Shank  
HSS, 3/4" Shank, 6" Overall Length  
Packed in Wooden Case  
1", 1-1/8", 1-1/4", 1-3/8", 1-1/2"

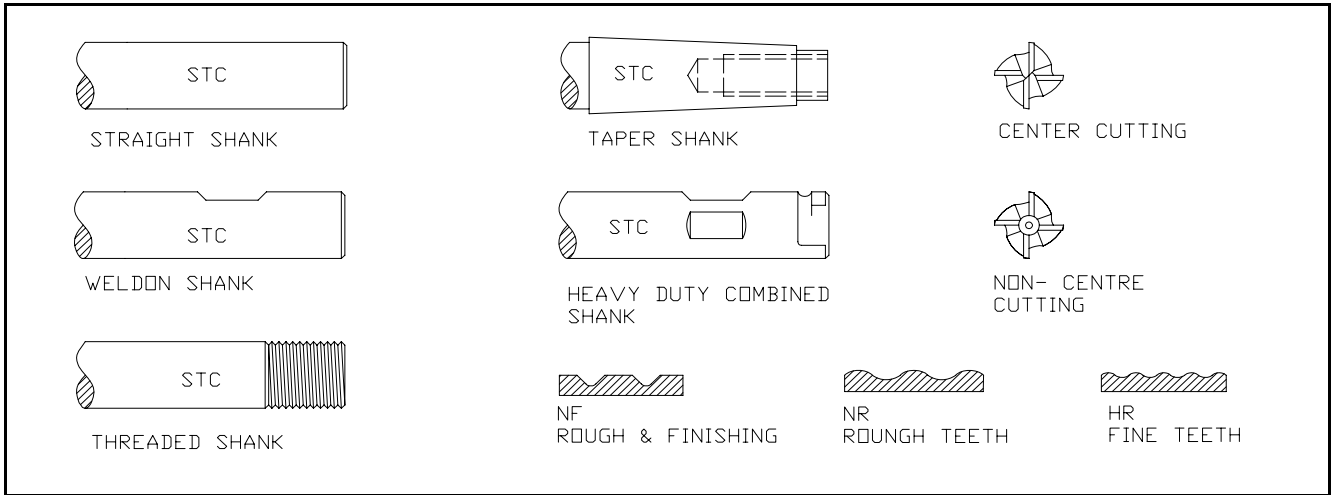

## STC048, HSS STRAIGHT SHANK 2-FLUTE END MILL

DIN327, GOST 9140

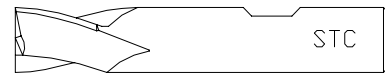

### STC048-1, REGULAR LENGTH

Cut Diameter	Shank Diameter	Flute Length	Overall Length
2	6	4	48
2.5	6	5	49
3	6	6	50
4	6	7	51
5	6	8	52
6	6	8	52
7	10	10	60
8	10	11	61
10	10	13	63

Cut Diameter	Shank Diameter	Flute Length	Overall Length
12	12	16	73
14	12	16	73
16	16	19	79
18	16	19	79
20	20	22	88
22	20	22	88
24	25	26	102
25	25	26	102
28	25	26	102

Cut Diameter	Shank Diameter	Flute Length	Overall Length
32	32	32	112
36	32	32	112
40	40	38	130
45	40	38	130
50	50	45	147
56	50	45	147
63	50	53	155

### STC048-2, LONG LENGTH

Cut Diameter	Shank Diameter	Flute Length	Overall Length
2	6	7	51
2.5	6	8	52
3	6	8	52
4	6	11	55
5	6	13	57
6	6	13	57
7	10	16	66
8	10	19	69
10	10	22	72

Cut Diameter	Shank Diameter	Flute Length	Overall Length
12	12	26	83
14	12	26	83
16	16	32	92
18	16	32	92
20	20	38	104
22	20	38	104
24	25	45	121
25	25	45	121
28	25	45	121

Cut Diameter	Shank Diameter	Flute Length	Overall Length
32	32	53	133
36	32	53	133
40	40	63	155
45	40	63	155
50	50	75	177
56	50	75	177
63	50	90	192

## STC188, HSS STRAIGHT 3-FLUTE END MILL

DIN844, GOST17025



### REGULAR LENGTH, 45° HELICAL ANGLE. NON-CENTER CUTTING

Size	Shank Diameter	Flute Length	Overall Length
2	6	7	51
2.5	6	8	52
3	6	8	52
4	6	11	55
5	6	13	57
6	6	13	57

Size	Shank Diameter	Flute Length	Overall Length
7	10	16	66
8	10	19	69
10	10	22	72
12	12	26	83
14	12	26	83
16	16	32	92

Size	Shank Diameter	Flute Length	Overall Length
18	16	32	92
20	20	38	104
22	20	38	104
25	25	45	121
28	25	45	121

## STC047, HSS STRAIGHT SHANK END MILL

DIN844, GOST 17025

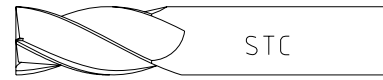

### STC047-1, REGULAR LENGTH

Size	Shank Diameter	Flute Length	Overall Length
2	6	7	51
2.5	6	8	52
3	6	8	52
4	6	11	55
5	6	13	57
6	6	13	57
7	10	16	66
8	10	19	69

Size	Shank Diameter	Flute Length	Overall Length
10	10	22	72
12	12	26	83
14	12	26	83
16	16	32	92
18	16	32	92
20	20	38	104
22	20	38	104
25	25	45	121

Size	Shank Diameter	Flute Length	Overall Length
28	25	45	121
32	32	53	133
36	32	53	133
40	40	63	155
45	40	63	155
50	50	75	177
56	50	75	177
63	50	90	192

### STC047-2, LONG LENGTH

Size	Shank Diameter	Flute Length	Overall Length
2	6	10	54
2.5	6	12	56
3	6	12	56
4	6	19	63
5	6	24	68
6	6	24	68
7	10	30	80
8	10	38	88

Size	Shank Diameter	Flute Length	Overall Length
10	10	45	95
12	12	53	110
14	12	53	110
16	16	63	123
18	16	63	123
20	20	75	141
22	20	75	141
25	25	90	166

Size	Shank Diameter	Flute Length	Overall Length
28	25	90	166
32	32	106	186
36	32	106	186
40	40	125	217
45	40	125	217
50	50	150	252
56	50	150	252
63	50	190	282

## STC055, BALL NOSE END MILL, 2-FLUTE

Ball Nose Radius equals half diameter of cut



Size	Shank Diameter	Flute Length	Overall Length
2	6	4	48
3	6	6	50
4	6	7	51
5	6	8	52
6	6	8	52
7	10	10	60

Size	Shank Diameter	Flute Length	Overall Length
8	10	11	61
9	10	13	63
10	10	13	63
11	12	16	73
12	12	16	73
14	12	16	73

Size	Shank Diameter	Flute Length	Overall Length
16	16	19	79
18	16	19	79
20	20	22	88
22	20	22	88
24	25	26	102
25	25	26	102

## STC055A, BALL NOSE END MILL, 4-FLUTE

Ball Nose Radius equals half diameter of cut



Size	Shank Diameter	Flute Length	Overall Length
2	6	7	51
3	6	8	52
4	6	11	55
5	6	13	57
6	6	13	57
7	10	16	66

Size	Shank Diameter	Flute Length	Overall Length
8	10	19	69
9	10	19	69
10	10	22	72
11	12	22	79
12	12	22	79
14	12	22	79

Size	Shank Diameter	Flute Length	Overall Length
16	16	32	92
18	16	32	92
20	20	38	104
22	20	38	104
25	25	45	121
30	25	45	121

## STC048T, HSS TAPER SHANK 2-FLUTE END MILL

DIN326, GOST9140



### STC048T-1, REGULAR LENGTH

Szie	Morse Taper	Flute Length	Overall Length
10	1	13	83
12	1	16	86
14	2	16	101
16	2	19	104
18	2	19	104
20	2	22	107

Szie	Morse Taper	Flute Length	Overall Length
22	2	22	107
24	3	26	128
25	3	26	128
28	3	26	128
32	4	32	157
36	4	32	157

Szie	Morse Taper	Flute Length	Overall Length
40	4	38	163
45	4	38	163
50	5	45	203
56	5	45	203
63	5	53	211

### STC048T-2, LONG LENGTH

Szie	Morse Taper	Flute Length	Overall Length
10	1	22	92
12	1	26	96
14	2	26	111
16	2	32	117
18	2	32	117
20	2	38	123

Szie	Morse Taper	Flute Length	Overall Length
22	2	38	123
24	3	45	147
25	3	45	147
28	3	45	147
32	4	53	178
36	4	53	178

Szie	Morse Taper	Flute Length	Overall Length
40	4	63	188
45	4	63	188
50	5	75	233
56	5	75	233
63	5	90	248

## STC061, HSS TAPER SHANK END MILL

DIN845, GOST17026



### REGULAR LENGTH

Size	Morse Taper	Flute Length	Overall Length
10	1	22	92
12	1	26	96
14	2	26	111
16	2	32	117
18	2	32	117
20	2	38	123

### NON-CENTER CUTTING

Size	Morse Taper	Flute Length	Overall Length
22	2	38	123
25	3	45	147
28	3	45	147
32	4	53	178
36	4	53	178
40	4	63	188

Size	Morse Taper	Flute Length	Overall Length
45	4	63	188
50	5	75	233
56	5	75	233
63	5	90	248

### LONG LENGTH

Size	Morse Taper	Flute Length	Overall Length
10	1	45	115
12	1	53	123
14	2	53	138
16	2	63	148
18	2	63	148
20	2	75	160

### NON-CENTER CUTTING

Size	Morse Taper	Flute Length	Overall Length
22	2	75	160
25	3	90	192
28	3	90	192
32	4	106	231
36	4	106	231
40	4	125	250

Size	Morse Taper	Flute Length	Overall Length
45	4	125	250
50	5	150	308
56	5	150	308
63	5	180	338

## STC062A, HSS ROUGHING END MILL

DIN844

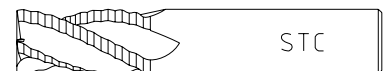

### STC062A-1, REGULAR LENGTH

Size	Shank Diameter	Flute Length	Overall Length
6	6	13	57
7	10	16	66
8	10	19	69
10	10	22	72
12	12	26	83
14	12	26	83
16	16	32	92

Size	Shank Diameter	Flute Length	Overall Length
18	16	32	92
20	20	38	104
22	20	38	104
25	25	45	121
28	25	45	121
32	32	53	133
36	32	53	133

Size	Shank Diameter	Flute Length	Overall Length
40	40	63	155
45	40	63	155
50	50	75	177
56	50	75	177
63	50	90	192

## STC062A, HSS ROUGHING END MILL

### STC062A-2, LONG LENGTH

Size	Shank Diameter	Flute Length	Overall Length
6	6	24	68
7	10	30	80
8	10	38	88
10	10	45	95
12	12	53	110
14	12	53	110
16	16	63	123

Size	Shank Diameter	Flute Length	Overall Length
18	16	63	123
20	20	75	141
22	20	75	141
25	25	90	166
28	25	90	166
32	32	106	186
36	32	106	186

Size	Shank Diameter	Flute Length	Overall Length
40	40	125	217
45	40	125	217
50	50	150	252
56	50	150	252
63	50	190	282

## STC061, HSS TAPER SHANK ROUGHING END MILL, DIN845

### REGULAR LENGTH

### NON-CENTER CUTTING

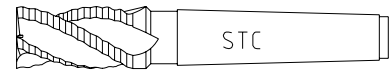

Size	Morse Taper	Flute Length	Overall Length
10	1	22	92
12	1	26	96
14	2	26	111
16	2	32	117
18	2	32	117
20	2	38	123

Size	Morse Taper	Flute Length	Overall Length
22	2	38	123
25	3	45	147
28	3	45	147
32	4	53	178
36	4	53	178
40	4	63	188

Size	Morse Taper	Flute Length	Overall Length
45	4	63	188
50	5	75	233
56	5	75	233
63	5	90	248

### LONG LENGTH

### NON-CENTER CUTTING

Size	Morse Taper	Flute Length	Overall Length
10	1	45	115
12	1	53	123
14	2	53	138
16	2	63	148
18	2	63	148
20	2	75	160

Size	Morse Taper	Flute Length	Overall Length
22	2	75	160
25	3	90	192
28	3	90	192
32	4	106	231
36	4	106	231
40	4	125	250

Size	Morse Taper	Flute Length	Overall Length
45	4	125	250
50	5	150	308
56	5	150	308
63	5	180	338

## STC198, SOLID CARBIDE 2-FLUTE END MILL, DIN327

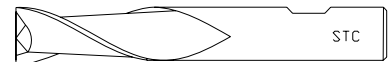

Cutting Diameter	Shank Diameter	Flute Length	Overall Length
1.5	6	4	48
2	6	4	48
2.5	6	5	49
3	6	6	50
4	6	7	51
5	6	8	52

Cutting Diameter	Shank Diameter	Flute Length	Overall Length
6	6	8	52
7	10	10	60
8	10	11	61
10	10	13	63
12	12	16	73
14	12	16	73

Cutting Diameter	Shank Diameter	Flute Length	Overall Length
16	16	19	79
18	16	19	79
20	20	22	88
22	20	22	88
24	25	26	102
25	25	26	102

## STC186, SOLID CARBIDE 4-FLUTE END MILL



Size	Shank Diameter	Flute Length	Overall Length
1.5	2	7	39
2	2	7	39
2.5	3	8	40
3	3	8	40
4	4	11	43
5	5	13	47

Size	Shank Diameter	Flute Length	Overall Length
6	6	13	57
7	10	16	66
8	10	19	69
10	10	22	72
12	12	26	83
14	12	26	83

Size	Shank Diameter	Flute Length	Overall Length
16	16	32	92
18	16	32	92
20	20	38	104
22	20	38	104
25	25	45	121

## STC199, STRAIGHT SHANK CARBIDE TIPPED END MILL

STRAIGHT TEETH,

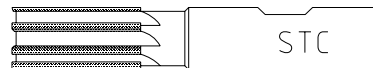

Size	Shank Diameter	Flute Length	Overall Length
8	8	12	63
10	10	12	63
12	12	16	75
14	12	16	75

Size	Shank Diameter	Flute Length	Overall Length
16	16	16	80
18	16	19	80
20	20	19	90
22	20	22	100

Size	Shank Diameter	Flute Length	Overall Length
25	25	22	100
30	25	22	100

## STC152M, CARBIDE TIPPED END MILL

HELICAL TEETH,



Size	Shank Diameter	Flute Length	Overall Length
12	12	20	75
12	12	25	80
16	16	25	88
16	16	32	95

Size	Shank Diameter	Flute Length	Overall Length
20	20	32	97
20	20	40	105
25	25	40	111
25	25	50	121

Size	Shank Diameter	Flute Length	Overall Length
32	32	40	120
32	32	50	130
40	40	50	140
40	40	63	153

## STC200, TAPER SHANK CARBIDE TIPPED END MILL

HELICAL TEETH,



Size	Morse Taper	Flute Length	Overall Length
16	2	25	110
16	2	32	117
20	2	32	117
20	2	40	125
20	3	40	142

Size	Morse Taper	Flute Length	Overall Length
25	3	40	142
25	3	50	152
32	4	40	165
32	4	50	175
40	4	50	181

Size	Morse Taper	Flute Length	Overall Length
40	4	63	194
50	4	63	194
50	5	80	238
63	5	63	221
63	5	100	258

## STC049, HSS 4-FLUTE END MILL

ANSI/ASME B94.19

REGULAR LENGTH



Size	Shank Diameter	Length of Cut	Overall Length
1/8"	3/8"	3/8"	2-5/16"
5/32"	3/8"	7/16"	2-3/8"
3/16"	3/8"	1/2"	2-3/8"
7/32"	3/8"	9/16"	2-7/16"
1/4"	3/8"	5/8"	2-7/16"
9/32"	3/8"	11/16"	2-1/2"
5/16"	3/8"	3/4"	2-1/2"
11/32"	3/8"	3/4"	2-1/2"
3/8"	3/8"	3/4"	2-1/2"
13/32"	3/8"	1"	2-11/16"
7/16"	3/8"	1"	2-11/16"
15/32"	3/8"	1"	2-11/16"
1/2"	3/8"	1"	2-11/16"
1/2"	1/2"	1-1/4"	3-1/4"
9/16"	1/2"	1-3/8"	3-3/8"
5/8"	1/2"	1-3/8"	3-3/8"
5/8"	5/8"	1-5/8"	3-3/4"
11/16"	1/2"	1-3/8"	3-3/8"
11/16"	5/8"	1-5/8"	3-3/4"

Size	Shank Diameter	Length of Cut	Overall Length
3/4"	1/2"	1-5/8"	3-5/8"
3/4"	5/8"	1-5/8"	3-3/4"
3/4"	3/4"	1-5/8"	3-3/4"
3/4"	3/4"	1-5/8"	3-7/8"
13/16"	5/8"	1-5/8"	3-3/4"
13/16"	5/8"	1-7/8"	4"
13/16"	3/4"	1-7/8"	4-1/8"
7/8"	5/8"	1-7/8"	4"
7/8"	3/4"	1-7/8"	4-1/8"
7/8"	7/8"	1-7/8"	4-1/8"
15/16"	5/8"	1-7/8"	4-1/8"
15/16"	3/4"	1-17/8"	4-1/8"
1"	5/8"	1-7/8"	4-1/8"
1"	3/4"	1-7/8"	4-1/8"
1"	7/8"	1-7/8"	4-1/8"
1"	1"	2"	4-1/2"
1-1/8"	3/4"	2"	4-1/2"
1-1/8"	7/8"	2"	4-1/2"
1-1/8"	1"	2"	4-1/2"

Size	Shank Diameter	Length of Cut	Overall Length
1-1/4"	3/4"	2"	4-1/2"
1-1/4"	7/8"	2"	4-1/2"
1-1/4"	1"	2"	4-1/2"
1-1/4"	1-1/4"	2"	4-1/2"
1-3/8"	3/4"	2"	4-1/2"
1-3/8"	1"	2"	4-1/2"
1-1/2"	3/4"	2"	4-1/2"
1-1/2"	1"	2"	4-1/2"
1-1/2"	1-1/4"	2"	4-1/2"
1-5/8"	3/4"	2"	4-1/2"
1-5/8"	1-1/4"	2"	4-1/2"
1-3/4"	3/4"	2"	4-1/2"
1-3/4"	1-1/4"	2"	4-1/2"
1-7/8"	3/4"	2"	4-1/2"
1-7/8"	1-1/4"	2"	4-1/2"
2"	3/4"	2"	4-1/2"
2"	1-1/4"	2"	4-1/2"

## STC049, HSS 4-FLUTE END MILL

ANSI/ASME B94.19  
LONG LENGTH

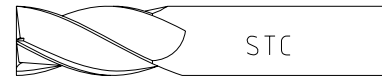

Size	Shank Diameter	Length of Cut	Overall Length
1/4"	3/8"	1-1/4"	3-1/16"
5/16"	3/8"	1-3/8"	3-1/8"
3/8"	3/8"	1-1/2"	3-1/4"
7/16"	3/8"	1-3/4"	3-3/4"
1/2"	1/2"	2"	4"
5/8"	1/2"	2-1/2"	4-5/8"
5/8"	5/8"	2-1/2"	4-5/8"
3/4"	1/2"	3"	5-1/4"

Size	Shank Diameter	Length of Cut	Overall Length
3/4"	5/8"	3"	5-1/4"
3/4"	3/4"	3"	5-1/4"
7/8"	3/4"	3-1/2"	5-3/4"
7/8"	7/8"	3-1/2"	5-3/4"
1"	3/4"	4"	6-1/2"
1"	1"	4"	6-1/2"
1-1/8"	1"	4"	6-1/2"
1-1/4"	1"	4"	6-1/2"

Size	Shank Diameter	Length of Cut	Overall Length
1-1/4"	1-1/4"	4"	6-1/2"
1-3/8"	1"	4"	6-1/2"
1-1/2"	1"	4"	6-1/2"
1-1/2"	1-1/4"	4"	6-1/2"
1-5/8"	1-1/4"	4"	6-1/2"
1-3/4"	1-1/4"	4"	6-1/2"
2"	1-1/4"	4"	6-1/2"

### EXTRA LONG LENGTH

Size	Shank Diameter	Length of Cut	Overall Length
1/4"	3/8"	1-3/4"	3-9/16"
5/16"	3/8"	2"	3-3/4"
3/8"	3/8"	2-1/2"	4-1/4"
1/2"	1/2"	3"	5"

Size	Shank Diameter	Length of Cut	Overall Length
5/8"	5/8"	4"	6-1/8"
3/4"	1/2"	4"	6-1/4"
3/4"	3/4"	4"	6-1/4"
7/8"	7/8"	5"	7-1/4"

Size	Shank Diameter	Length of Cut	Overall Length
1"	1"	6"	8-1/2"
1-1/4"	1-1/4"	6"	8-1/2"
1-1/2"	1-1/4"	6"	8-1/2"
1-1/2"	1-1/4"	8"	10-1/2"

## STC050A, HSS 2-FLUTE END MILL

ANSI/ASME B94.19



### REGULAR LENGTH

Size	Shank Diameter	Length of Cut	Overall Length
1/8"	3/8"	38"	2-1/15/16"
5/32"	3/8"	7/16"	2-1/15/16"
3/16"	3/8"	7/16"	2-1/15/16"
7/32"	3/8"	1/2"	2-1/15/16"
1/4"	3/8"	1/2"	2-1/15/16"
9/32"	3/8"	9/16"	2-1/15/16"
5/16"	3/8"	9/16"	2-1/15/16"
11/32"	3/8"	9/16"	2-1/15/16"
3/8"	3/8"	9/16"	2-1/15/16"
13/32"	3/8"	13/16"	2-1/2"
7/16"	3/8"	13/16"	2-1/2"
15/32"	3/8"	13/16"	2-1/2"
1/2"	3/8"	13/16"	2-1/2"
1/2"	1/2"	1"	3"
9/16"	1/2"	1-1/8"	3-1/8"
5/8"	1/2"	1-1/8"	3-1/8"
5/8"	5/8"	1-15/16"	3-7/16"
11/16"	1/2"	1-15/16"	3-5/16"

Size	Shank Diameter	Length of Cut	Overall Length
11/16"	5/8"	1-15/16"	3-7/16"
3/4"	1/2"	1-15/16"	3-5/16"
3/4"	5/8"	1-15/16"	3-7/16"
3/4"	3/4"	1-15/16"	3-9/16"
13/16"	1/2"	1-1/2"	3-1/2"
13/16"	5/8"	1-1/2"	3-5/8"
7/8"	1/2"	1-1/2"	3-1/2"
7/8"	5/8"	1-1/2"	3-5/8"
7/8"	3/4"	1-1/2"	3-3/4"
7/8"	7/8"	1-1/2"	3-3/4"
15/16"	1/2"	1-1/2"	3-5/8"
15/16"	5/8"	1-1/2"	3-1/2"
15/16"	3/4"	1-1/2"	3-3/4"
1"	5/8"	1-1/2"	3-5/8"
1"	3/4"	1-1/2"	3-3/4"
1"	7/8"	1-1/2"	3-3/4"
1"	1"	1-5/8"	4-1/8"
1-1/8"	3/4"	1-5/8"	3-7/8"

Size	Shank Diameter	Length of Cut	Overall Length
1-1/8"	1"	1-5/8"	4-1/8"
1-1/4"	3/4"	1-5/8"	3-7/8"
1-1/4"	1"	1-5/8"	4-1/8"
1-1/4"	1-1/4"	1-5/8"	4-1/8"
1-3/8"	3/4"	1-5/8"	3-7/8"
1-3/8"	1"	1-5/8"	4-1/8"
1-1/2"	3/4"	1-5/8"	3-7/8"
1-1/2"	1"	1-5/8"	4-1/8"
1-1/2"	1-1/4"	1-5/8"	4-1/8"
1-5/8"	3/4"	1-5/8"	3-7/8"
1-5/8"	1-1/4"	1-5/8"	4-1/8"
1-3/4"	3/4"	1-5/8"	3-7/8"
1-3/4"	1-1/4"	1-5/8"	4-1/8"
1-7/8"	3/4"	1-5/8"	3-7/8"
1-7/8"	1-1/4"	1-5/8"	4-1/8"
2"	1-1/4"	1-5/8"	4-1/8"

## STC050B, HSS 2-FLUTE END MILL, INCH SIZE.

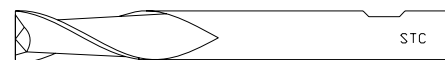

### LONG LENGTH

Size	Shank Diameter	Length of Cut	Overall Length
1/4"	3/8"	1-1/4"	3-1/8"
5/16"	3/8"	1-1/2"	3-1/4"
3/8"	3/8"	1-1/2"	3-1/4"
1/2"	1/2"	2"	4"
5/8"	5/8"	2"	4-1/8"

Size	Shank Diameter	Length of Cut	Overall Length
3/4"	3/4"	2-1/4"	4-1/2"
7/8"	7/8"	2-1/2"	4-3/4"
1"	1"	3"	5-1/2"
1-1/4"	1-1/4"	3"	5-1/2"
1-3/8"	1"	3"	5-1/2"

Size	Shank Diameter	Length of Cut	Overall Length
1-1/2"	1-1/4"	3"	5-1/2"
1-5/8"	1-1/4"	3"	5-1/2"
1-3/4"	1-1/4"	3"	5-1/2"
1-7/8"	1-1/4"	3"	5-1/2"
2"	1-1/4"	3"	5-1/2"

## STC050C, HSS 2-FLUTE END MILL, INCH SIZE.

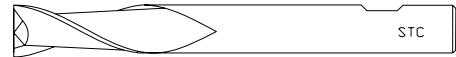

### EXTENDED SHANK

Size	Shank Diameter	Length of Cut	Overall Length
1/4"	3/8"	5/8"	3-1/16"
5/16"	3/8"	3/4"	3-5/16"
3/8"	3/8"	3/4"	3-5/16"

Size	Shank Diameter	Length of Cut	Overall Length
1/2"	1/2"	1"	4"
5/8"	5/8"	1-3/8"	4-5/8"
3/4"	3/4"	1-5/8"	5-3/8"

Size	Shank Diameter	Length of Cut	Overall Length
7/8"	7/8"	2"	6"
1"	1"	2-1/2"	7-1/4"
1-1/4"	1-1/4"	3"	7-1/4"

## STC052A, HSS 4-FLUTE DOUBLE END MILL



Size	Shank Diameter	Length of Cut	Overall Length
1/8"	3/8"	3/8"	3-1/16"
5/32"	3/8"	7/16"	3-1/8"
3/16"	3/8"	1/2"	3-1/4"
7/32"	3/8"	9/16"	3-1/4"
1/4"	3/8"	5/8"	3-3/8"
9/32"	3/8"	11/16"	3-3/8"
5/16"	3/8"	3/4"	3-1/2"

Size	Shank Diameter	Length of Cut	Overall Length
11/32"	3/8"	3/4"	3-1/2"
3/8"	3/8"	3/4"	3-1/2"
13/32"	1/2"	1"	4-1/8"
7/16"	1/2"	1"	4-1/8"
15/32"	1/2"	1"	4-1/8"
1/2"	1/2"	1"	4-1/8"
9/16"	5/8"	1-3/8"	5"

Size	Shank Diameter	Length of Cut	Overall Length
5/8"	5/8"	1-3/8"	5"
11/16"	3/4"	1-5/8"	5-5/8"
3/4"	3/4"	1-7/8"	5-5/8"
13/16"	7/8"	1-7/8"	6-1/8"
7/8"	7/8"	1-7/8"	6-1/8"
15/16"	1"	1-7/8"	6-1/8"
1"	1"	1-7/8"	6-1/8"

## STC052B, HSS 2-FLUTE DOUBLE END MILL



Size	Shank Diameter	Length of Cut	Overall Length
1/8"	3/8"	3/8"	3-1/16"
5/32"	3/8"	7/16"	3-1/8"
3/16"	3/8"	7/16"	3-1/8"
7/32"	3/8"	1/2"	3-1/8"
1/4"	3/8"	1/2"	3-1/8"
9/32"	3/8"	9/16"	3-1/8"
5/16"	3/8"	9/16"	3-1/8"

Size	Shank Diameter	Length of Cut	Overall Length
11/32"	3/8"	9/16"	3-1/8"
3/8"	3/8"	9/16"	3-1/8"
13/32"	1/2"	13/16"	3-3/4"
7/16"	1/2"	13/16"	3-3/4"
15/32"	1/2"	13/16"	3-3/4"
1/2"	1/2"	13/16"	3-3/4"
9/16"	5/8"	1-1/8"	4-1/2"

Size	Shank Diameter	Length of Cut	Overall Length
5/8"	5/8"	1-1/8"	4-1/2"
11/16"	3/4"	1-5/16"	5"
3/4"	3/4"	1-5/16"	5"
13/16"	7/8"	1-9/16"	5-1/2"
7/8"	7/8"	1-9/16"	5-1/2"
15/16"	1"	1-5/8"	5-7/8"
1"	1"	1-5/8"	5-7/8"

## STC054, 3/16" SHANK 2-FLUTE DOUBLE END MILL



Size	Shank Diameter	Length of Cut	Overall Length
1/32"	3/16"	3/32"	2-1/4"
3/64"	3/16"	9/64"	2-1/4"
1/16"	3/16"	3/16"	2-1/4"
5/64"	3/16"	15/64"	2-1/4"

Size	Shank Diameter	Length of Cut	Overall Length
3/32"	3/16"	9/32"	2-1/4"
7/64"	3/16"	21/64"	2-1/4"
1/8"	3/16"	3/8"	2-1/4"
9/64"	3/16"	13/32"	2-1/4"

Size	Shank Diameter	Length of Cut	Overall Length
5/32"	3/16"	7/16"	2-1/4"
11/64"	3/16"	1/2"	2-1/4"
3/16"	3/16"	1/2"	2-1/4"

## STC054B, 3/16" SHANK 4-FLUTE DOUBLE END MILL



Size	Shank Diameter	Length of Cut	Overall Length
1/32"	3/16"	3/32"	2-1/4"
3/64"	3/16"	9/64"	2-1/4"
1/16"	3/16"	3/16"	2-1/4"
5/64"	3/16"	15/64"	2-1/4"

Size	Shank Diameter	Length of Cut	Overall Length
3/32"	3/16"	9/32"	2-1/4"
7/64"	3/16"	21/64"	2-1/4"
1/8"	3/16"	3/8"	2-1/4"
9/64"	3/16"	13/32"	2-1/4"

Size	Shank Diameter	Length of Cut	Overall Length
5/32"	3/16"	7/16"	2-1/4"
11/64"	3/16"	1/2"	2-1/4"
3/16"	3/16"	1/2"	2-1/4"

## STC056, BALL NOSE END MILL, 2-FLUTE, INCH SIZE

Ball Nose Radius equals half diameter of cut

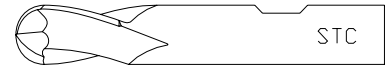

### REGULAR LENGTH

Size	Shank Diameter	Length of Cut	Overall Length
1/8"	3/8"	3/8"	2-5/16"
3/16"	3/8"	1/2"	2-3/8"
1/4"	3/8"	5/8"	2-7/16"
5/16"	3/8"	3/4"	2-1/2"
3/8"	3/8"	3/4"	2-1/2"
7/16"	1/2"	1"	3"

Size	Shank Diameter	Length of Cut	Overall Length
1/2"	1/2"	1"	3"
9/16"	1/2"	1-1/8"	3-1/2"
5/8"	1/2"	1-1/8"	3-1/8"
5/8"	5/8"	1-3/8"	3-1/2"
3/4"	1/2"	1-5/16"	3-5/16"
3/4"	3/4"	1-5/8"	3-7/8"

Size	Shank Diameter	Length of Cut	Overall Length
7/8"	7/8"	2"	4-1/4"
1"	1"	2-1/4"	4-3/4"
1-1/8"	1"	2-1/4"	4-3/4"
1-1/4"	1-1/4"	2-1/2"	5"
1-1/2"	1-1/4"	2-1/2"	5"
2"	1-1/4"	2-1/2"	5"

## STC058A, BALL NOSE END MILL, 4-FLUTE, INCH SIZE

Ball Nose Radius equals half diameter of cut



### REGULAR LENGTH

Size	Shank Diameter	Length of Cut	Overall Length
1/4"	3/8"	3/4"	2-9/16"
5/16"	3/8"	1"	2-3/4"
3/8"	3/8"	1"	2-3/4"
1/2"	1/2"	1-1/4"	3-1/4"

Size	Shank Diameter	Length of Cut	Overall Length
5/8"	5/8"	1-5/8"	3-3/4"
3/4"	3/4"	1-5/8"	3-7/8"
7/8"	7/8"	1-7/8"	4-1/8"
1"	1"	2"	4-1/2"

Size	Shank Diameter	Length of Cut	Overall Length
1-1/4"	1-1/4"	2"	4-1/2"
1-1/2"	1-1/4"	2"	4-1/2"

### REGULAR LENGTH

Size	Shank Diameter	Length of Cut	Overall Length
1/4"	3/8"	1-1/4"	3-1/16"
5/16"	3/8"	1-1/2"	3-1/4"
3/8"	3/8"	1-1/2"	3-1/4"

Size	Shank Diameter	Length of Cut	Overall Length
1/2"	1/2"	2"	4"
5/8"	5/8"	2-1/2"	4-5/8"
3/4"	3/4"	3"	5-1/4"

Size	Shank Diameter	Length of Cut	Overall Length
1"	1"	4"	6-1/2"

## STC062, ROUGHING END MILL, 4-FLUTE, INCH SIZE

TOOTH TYPE: COARSE PITCH, FINE PITCH, ROUGHING & FINISHED.

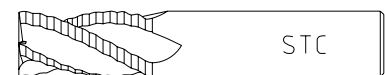

### REGULAR LENGTH

Size	Shank Diameter	Length of Cut	Overall Length
1/4"	3/8"	5/8"	2-7/16"
5/16"	3/8"	3/4"	2-1/2"
3/8"	3/8"	3/4"	2-1/2"
1/2"	1/2"	1-1/4"	3-1/4"
5/8"	5/8"	1-5/8"	3-3/4"
3/4"	5/8"	1-5/8"	3-3/4"

Size	Shank Diameter	Length of Cut	Overall Length
3/4"	3/4"	1-5/8"	3-7/8"
7/8"	3/4"	1-7/8"	4-1/8"
7/8"	7/8"	1-7/8"	4-1/8"
1"	3/4"	2"	4-1/4"
1"	1"	2"	4-1/2"
1-1/8"	1"	2"	4-1/2"

Size	Shank Diameter	Length of Cut	Overall Length
1-1/4"	1"	2"	4-1/2"
1-1/4"	1-1/4"	2"	4-1/2"
1-1/2"	1-1/4"	2"	4-1/2"
1-3/4"	1-1/4"	2"	4-1/2"
2"	1-1/4"	2"	4-1/2"
2"	2"	3"	6-3/4"

### LONG LENGTH

Size	Shank Diameter	Length of Cut	Overall Length
1/4"	3/8"	1-1/4"	3-1/16"
5/16"	3/8"	1-3/8"	3-1/8"
3/8"	3/8"	1-1/2"	3-1/4"
1/2"	1/2"	2"	4"
5/8"	5/8"	2-1/2"	4-5/8"
3/4"	5/8"	3"	5-1/8"

Size	Shank Diameter	Length of Cut	Overall Length
3/4"	3/4"	3"	5-1/4"
7/8"	3/4"	3-1/2"	5-3/4"
7/8"	7/8"	3-1/2"	5-3/4"
1"	1"	4"	6-1/2"
1-1/4"	3/4"	4"	6-1/4"
1-1/4"	1-1/4"	3"	5-1/2"

Size	Shank Diameter	Length of Cut	Overall Length
1-1/4"	1-1/4"	4"	6-1/2"
1-1/2"	3/4"	4"	6-1/4"
1-1/2"	1-1/4"	4"	6-1/2"
1-3/4"	1-1/4"	4"	6-1/2"
2"	1-1/4"	4"	6-1/2"
2"	2"	4"	7-3/4"

## STC058A, SOLID CARBIDE 4-FLUTE END MILL, INCH SIZE



### REGULAR LENGTH

Size	Shank Diameter	Length of Cut	Overall Length
1/16"	1/8"	3/16"	1-1/2"
3/32"	1/8"	3/8"	1-1/2"
1/8"	1/8"	1/2"	1-1/2"
5/32"	3/16"	9/16"	2"
3/16"	3/16"	5/8"	2"
7/32"	1/4"	5/8"	2-1/2"

Size	Shank Diameter	Length of Cut	Overall Length
1/4"	1/4"	3/4"	2-1/2"
9/32"	5/16"	7/8"	2-1/2"
5/16"	5/16"	3/4"	2-1/2"
3/8"	3/8"	7/8"	2-1/2"
7/16"	7/16"	7/8"	2-1/2"
1/2"	1/2"	1"	3"

Size	Shank Diameter	Length of Cut	Overall Length
9/16"	9/16"	1-3/8"	3"
5/8"	5/8"	1-3/8"	3-1/2"
11/16"	3/4"	1-1/2"	4"
3/4"	3/4"	1-1/2"	4"
7/8"	7/8"	1-1/2"	4"
1"	1"	1-1/2"	4"

## STC195, SOLID CARBIDE 2-FLUTE END MILL, INCH SIZE



### REGULAR LENGTH

Size	Shank Diameter	Length of Cut	Overall Length
1/16"	1/8"	3/16"	1-1/2"
3/32"	1/8"	3/8"	1-1/2"
1/8"	1/8"	1/2"	1-1/2"
5/32"	3/16"	9/16"	2"
3/16"	3/16"	5/8"	2"
7/32"	1/4"	5/8"	2-1/2"

Size	Shank Diameter	Length of Cut	Overall Length
1/4"	1/4"	3/4"	2-1/2"
9/32"	5/16"	7/8"	2-1/2"
5/16"	5/16"	3/4"	2-1/2"
3/8"	3/8"	7/8"	2-1/2"
7/16"	7/16"	7/8"	2-1/2"
1/2"	1/2"	1"	3"

Size	Shank Diameter	Length of Cut	Overall Length
9/16"	9/16"	1-3/8"	3"
5/8"	5/8"	1-3/8"	3-1/2"
11/16"	3/4"	1-1/2"	4"
3/4"	3/4"	1-1/2"	4"
7/8"	7/8"	1-1/2"	4"
1"	1"	1-1/2"	4"

## STC152, CARBIDE TIPPED END MILL



### SPIRAL FLUTE, MULTIPLE FLUTE

Size	Shank Diameter	Length of Cut	Overall Length
1/4"	3/8"	1/2"	2-1/2"
5/16"	3/8"	5/8"	2-1/2"
3/8"	3/8"	5/8"	2-1/2"
7/16"	3/8"	1"	2-11/16"
1/2"	1/2"	1"	3-1/4"

Size	Shank Diameter	Length of Cut	Overall Length
9/16"	1/2"	1"	3-1/4"
5/8"	5/8"	1-1/4"	3-5/8"
3/4"	3/4"	1-1/2"	4-1/8"
7/8"	3/4"	1-1/4"	4"
1"	1"	1-3/4"	4-3/4"

Size	Shank Diameter	Length of Cut	Overall Length
1-1/8"	1"	1-3/4"	4-3/4"
1-1/4"	1-1/4"	2-1/8"	5-1/4"
1-1/2"	1-1/4"	1-1/2"	4-1/2"
1-3/4"	1-1/4"	2-1/2"	6-1/8"
2"	1-1/4"	1-1/2"	4-1/2"

## STC071A-1, T SLOT CUTTER

DIN851/1  
STRAIGHT SHANK

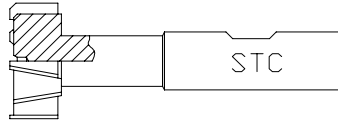

Size	Diameter of Cut	Width of Cut	Diameter of Neck	Overall Length	Shank Diameter
5	11	4.5	4	53.5	10
6	12.5	6	5	57	10
8	16	8	7	62	10
10	18	8	8	70	12
12	21	9	10	74	12
14	25	11	12	82	16
18	32	14	15	90	16
22	40	18	19	108	25
28	50	22	25	124	32
36	60	28	30	139	32

## STC071A-2, T SLOT CUTTER

DIN851/2  
TAPER SHANK

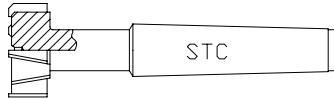

Size	Diameter of Cut	Width of Cut	Diameter of Neck	Overall Length	Shank M.T. No
10	18	8	8	82	MT1
12	21	9	10	98	MT2
14	25	11	12	103	MT2
18	32	14	15	111	MT2
22	40	18	19	138	MT3
28	50	22	25	173	MT4
36	60	28	30	188	MT4
42	72	35	36	229	MT5
48	85	40	42	240	MT5
54	95	44	44	251	MT5

## STC071A-3, T SLOT CUTTER

ANSI/ASME B94.19  
STRAIGHT SHANK

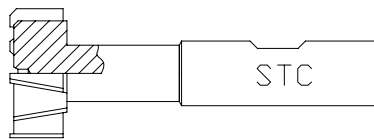

STRAIGHT SHANK                      INCH SIZES

Size	Diameter of Cut	Width of Cut	Diameter of Neck	Overall Length	Shank Diameter
1/4"	9/16"	15/64"	17/64"	2-19/32"	1/2"
5/16"	21/32"	17/64"	21/64"	2-11/16"	1/2"
3/8"	25/32"	21/64"	13/32"	3-1/4"	3/4"
1/2"	31/32"	25/64"	17/32"	3-7/16"	3/4"
5/8"	1-1/4"	31/64"	21/32"	3-15/16"	1"
3/4"	1-15/32"	5/8"	25/32"	4-7/16"	1"
1"	1-27/32"	53/64"	1-1/32"	4-13/16"	1-1/4"
1-1/4"	2-7/32"	1-3/32"	1-9/32"	5-3/8"	1-1/4"
1-1/2"	2-21/32"	1-11/32"	1-17/32"	5-29/32"	1-1/4"

## STC072, WOODRUFF KEYSEAT CUTTER

ANIS/ASME B94.19  
STRAIGHT TEETH

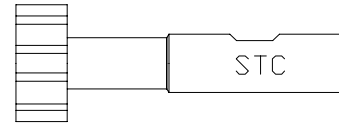

1/2" STRAIGHT SHANK

Cutter Number	Diameter of Cut	Width of Cut	Overall Length
202	1/4"	1/16"	2-1/16"
202-1/2	5/16"	1/16"	2-1/16"
302-1/2	5/16"	3/32"	2-3/32"
203	3/8"	1/16"	2-1/16"
303	3/8"	3/32"	2-3/32"
403	3/8"	1/8"	2-1/8"
204	1/2"	1/16"	2-1/16"
304	1/2"	3/32"	2-3/32"
404	1/2"	1/8"	2-1/8"
305	5/8"	3/32"	2-3/32"
405	5/8"	1/8"	2-1/8"
505	5/8"	5/32"	2-5/32"
605	5/8"	3/16"	2-3/16"
406	3/4"	1/8"	2-1/8"
506	3/4"	5/32"	2-5/32"
606	3/4"	3/16"	2-3/16"
806	3/4"	1/4"	2-1/4"
507	7/8"	5/32"	2-5/32"
607	7/8"	3/16"	2-3/16"
707	7/8"	7/32"	2-7/32"
807	7/8"	1/4"	2-1/4"
608	1"	3/16"	2-3/16"
708	1"	7/32"	2-7/32"
808	1"	1/4"	2-1/4"
1008	1"	5/16"	2-5/16"
1208	1"	3/8"	2-3/8"
609	1-1/8"	3/16"	2-3/16"
709	1-1/8"	7/32"	2-7/32"
809	1-1/8"	1/4"	2-1/4"
1009	1-1/8"	5/16"	2-5/16"
610	1-1/4"	3/16"	2-3/16"
710	1-1/4"	7/32"	2-7/32"
810	1-1/4"	1/4"	2-1/4"
1010	1-1/4"	5/16"	2-5/16"
1210	1-1/4"	3/8"	2-3/8"
811	1-3/8"	1/4"	2-1/4"
1011	1-3/8"	5/16"	2-5/16"
1211	1-3/8"	3/8"	2-3/8"
812	1-1/2"	1/4"	2-1/4"
1012	1-1/2"	5/16"	2-5/16"
1212	1-1/2"	3/8"	2-3/8"

## STC072M, WOODRUFF KEYSEAT CUTTER

DIN850  
STRAIGHT SHANK

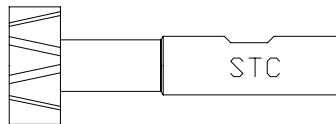

STRAIGHT TEETH & STAGGERED TEETH

Key Size	Cutter Diameter	Cutter Width	Overall Length	Shank Diameter
1 X 4	4.5	1	50	6
1.5 X 7	7.5	1.5	50	6
2 X 7	7.5	2	50	6
2 X 10	10.5	2	50	6
2.5 X 10	10.5	2.5	50	6
3 X 13	13.5	3	55	10
3 X 16	16.5	3	55	10
4 X 16	16.5	4	55	10
5 X 16	16.5	5	55	10
4 X 19	19.5	4	55	10
5 X 19	19.5	5	60	10
5 X 22	22.5	5	60	12
6 X 22	22.5	6	60	12
6 X 25	25.5	6	65	12
8 X 28	28.5	8	65	12
10 X 32	32.5	10	65	12

## STC073, DOVETAIL CUTTER

ANSI/ASME B94.19

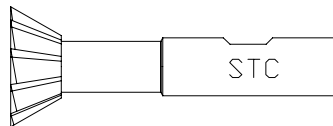

Angle	Cutter Diameter	Cutter Width	Overall Length	Shank Diameter
45°	3/8"	1/8"	2-1/8"	3/8"
	1/2"	5/32"	2-1/8"	3/8"
	3/4"	1/4"	2-1/8"	3/8"
	1-3/8"	7/16"	2-7/8"	5/8"
	1-7/8"	9/16"	3-1/4"	7/8"
	2-1/4"	5/8"	3-3/4"	1"
60°	3/8"	3/16"	2-1/8"	3/8"
	1/2"	1/4"	2-1/8"	3/8"
	3/4"	5/16"	2-1/8"	3/8"
	1-3/8"	9/16"	2-7/8"	5/8"
	1-7/8"	13/16"	3-1/4"	7/8"
	2-1/4"	1-1/16"	3-3/4"	1"

## STC073M, DOVETAIL CUTTER

DIN1833, TYPE A & C.  
STRAIGHT SHANK

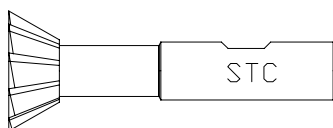

Angle	Cutter Diameter	Cutter Width	Overall Length	Shank Diameter
45°	16	4	60	12
	20	5	63	12
	25	6.3	67	16
	32	8	71	16

## STC073M, DOVETAIL CUTTER

DIN1833, TYPE A & C.

Angle	Cutter Diameter	Cutter Width	Overall Length	Shank Diameter
50°	16	6.3	60	12
	20	7.1	63	12
	25	9	67	16
	32	14	71	16
55°	16	6.3	60	12
	20	7.1	63	12
	25	9	67	16
	32	14	71	16
60°	16	6.3	60	12
	20	8	63	12
	25	10	67	16
	32	12.5	71	16

## STC073M, DOVETAIL CUTTER

INVERTED TYPE  
DIN1833, TYPE B & D  
STRAIGHT SHANK

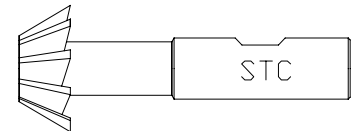

Angle	Cutter Diameter	Cutter Width	Overall Length	Shank Diameter
45°	16	4	60	12
	20	5	63	12
	25	6.3	67	16
	32	8	71	16
60°	16	6.3	60	12
	20	8	63	12
	25	10	67	16
	32	12.5	71	16

## STC073A, SINGLE-ANGLE MILLING CUTTER

ANSI/ASME B94.19  
STRAIGHT SHANK

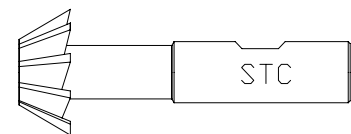

Angle	Cutter Diameter	Cutter Width	Overall Length	Shank Diameter
45°	1/2"	5/32"	2-1/8"	3/8"
	3/4"	1/4"	2-1/8"	3/8"
	1-3/8"	7/16"	2-7/8"	5/8"
	1-7/8"	5/8"	3-1/4"	7/8"
	2-1/4"	5/8"	3-3/4"	1"
60°	1/2"	1/4"	2-1/8"	3/8"
	3/4"	5/16"	2-1/8"	3/8"
	1-3/8"	9/16"	2-7/8"	5/8"
	1-7/8"	13/16"	3-1/4"	7/8"
	2-1/4"	1-1/16"	3-3/4"	1"

## STC209M, HSS PLAIN MILLING CUTTER

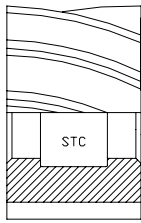

Inch Size

Size	Hole Diameter	Length of Cut
2-1/2"	1"	2"
2-1/2"	1"	3"
2-1/2"	1"	4"
3"	1-1/4"	1-1/2"

Size	Hole Diameter	Length of Cut
3"	1-1/4"	2"
3"	1-1/4"	2-1/2"
3"	1-1/4"	3"
3"	1-1/4"	4"

Size	Hole Diameter	Length of Cut
4"	1-1/2"	2"
4"	1-1/2"	3"
4"	1-1/2"	4"
4"	1-1/2"	6"

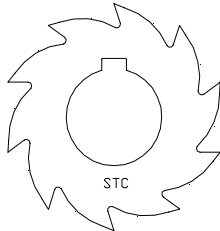

Metric Size DIN884

Size	Hole Diameter	Length of Cut
50	22	40
50	22	50
50	22	63
50	22	80
63	27	50
63	27	63

Size	Hole Diameter	Length of Cut
63	27	70
63	27	80
80	32	50
80	32	63
80	32	80
80	32	100

Size	Hole Diameter	Length of Cut
100	40	63
100	40	70
100	40	100
100	40	125

## STC208, HSS ROUGHING SHELL END MILL

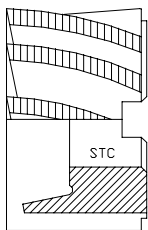

Size	Hole Diameter	Length of Cut
1-1/4"	1/2"	1"
1-1/2"	1/2"	1-1/8"
1-3/4"	3/4"	1-1/4"
2"	3/4"	1-3/8"
2"	3/4"	2"
2-1/4"	1"	1-1/2"
2-1/4"	1"	2"
2-1/2"	1"	1-5/8"

Size	Hole Diameter	Length of Cut
2-1/2"	1"	2"
2-3/4"	1"	1-5/8"
2-3/4"	1"	2"
3"	1-1/4"	1-3/4"
3"	1-1/4"	2"
3-1/2"	1-1/4"	1-7/8"
3-1/2"	1-1/4"	2"
4"	1-1/2"	2-1/4"

Size	Hole Diameter	Length of Cut
4"	1-1/2"	2-1/4"
4-1/2"	1-1/2"	2-1/4"
4-1/2"	1-1/2"	2-1/4"
5"	1-1/2"	2-1/4"
5"	1-1/2"	2-1/4"
5-1/2"	1-1/2"	2-1/4"
6"	1-1/2"	2-1/4"
6"	1-1/2"	2-1/4"

## STC067, HSS SHELL END MILL

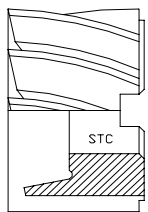

Size	Hole Diameter	Length of Cut
1-1/4"	1/2"	1"
1-1/2"	1/2"	1-1/8"
1-3/4"	3/4"	1-1/4"
2"	3/4"	1-3/8"
2-1/4"	1"	1-1/2"

Size	Hole Diameter	Length of Cut
2-1/2"	1"	1-5/8"
2-3/4"	1"	1-5/8"
3"	1-1/4"	1-3/4"
3-1/2"	1-1/4"	1-7/8"
4"	1-1/2"	2-1/4"

Size	Hole Diameter	Length of Cut
4-1/2"	1-1/2"	2-1/4"
5"	1-1/2"	2-1/4"
6"	2"	2-1/4"
6"	2"	2-1/4"

## STC208M, HSS ROUGHING SHELL END MILL

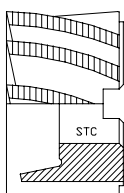

Size	Hole Diameter	Length of Cut	No. of Flute
40	16	32	6
50	22	36	8
63	27	40	8
80	27	45	10
100	32	50	10
125	40	56	12
160	50	63	12

## STC208B, SHELL END MILL

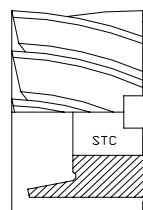

DIN1880

Size	Hole Diameter	Length of Cut	No. of Flute
40	16	32	6
50	22	36	8
63	27	40	8
80	27	45	10
100	32	50	10
125	40	56	12

## STC069, HSS SIDE & FACE CUTTER

ANSI/ASME B94.19

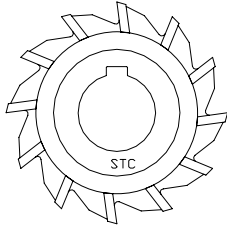

STRAIGHT TEETH

Size	Hole Diameter	Face Width
2"	5/8"	3/16"
2"	5/8"	1/4"
2"	5/8"	3/8"
2-1/2"	7/8"	1/4"
2-1/2"	7/8"	5/16"
2-1/2"	7/8"	3/8"
2-1/2"	7/8"	1/2"
3"	1"	1/4"
3"	1"	5/16"
3"	1"	3/8"
3"	1"	7/16"
3"	1"	1/2"
4"	1"	1/4"
4"	1"	3/8"

Size	Hole Diameter	Face Width
4"	1"	1/2"
4"	1"	5/8"
4"	1"	3/4"
4"	1"	7/8"
4"	1-1/4"	1/2"
4"	1-1/4"	5/8"
4"	1-1/4"	3/4"
5"	1"	3/8"
5"	1"	1/2"
5"	1"	5/8"
5"	1"	3/4"
5"	1-1/4"	1/2"
5"	1-1/4"	5/8"
5"	1-1/4"	3/4"

Size	Hole Diameter	Face Width
5"	1-1/4"	1"
6"	1"	3/8"
6"	1"	1/2"
6"	1-1/4"	1/2"
6"	1-1/4"	5/8"
6"	1-1/4"	3/4"
6"	1-1/4"	1"
7"	1-1/4"	3/4"
7"	1-14"	1"
8"	1-1/4"	3/4"
8"	1-1/4"	7/8"
8"	1-1/4"	1"

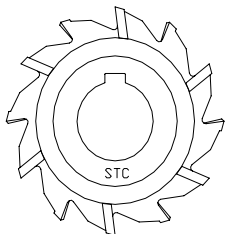

STAGGERED TEETH

Size	Hole Diameter	Face Width
2-1/2"	7/8"	1/4"
2-1/2"	7/8"	5/16"
2-1/2"	7/8"	3/8"
2-1/2"	7/8"	1/2"
3"	1"	3/16"
3"	1"	1/4"
3"	1"	5/16"
3"	1"	3/8"
3"	1-1/4"	1/2"
3"	1-1/4"	5/8"
3"	1-1/4"	3/4"
4"	1-1/4"	1/4"

Size	Hole Diameter	Face Width
4"	1-1/4"	5/16"
4"	1-1/4"	3/8"
4"	1-1/4"	7/16"
4"	1-1/4"	1/2"
4"	1-1/4"	5/8"
4"	1-1/4"	3/4"
4"	1-1/4"	7/8"
5"	1-1/4"	1/4"
5"	1-1/4"	5/16"
5"	1-1/4"	1/2"
5"	1-1/4"	5/8"
5"	1-1/4"	3/4"

Size	Hole Diameter	Face Width
6"	1-1/4"	5/16"
6"	1-1/4"	3/8"
6"	1-1/4"	1/2"
6"	1-1/4"	5/8"
6"	1-1/4"	3/4"
6"	1-1/4"	7/8"
6"	1-1/4"	1"
8"	1-1/2"	3/8"
8"	1-1/2"	1/2"
8"	1-1/2"	5/8"
8"	1-1/2"	3/4"
8"	1-1/2"	1"

## STC209, HSS SIDE & FACE CUTTER

DIN885, GOST28527

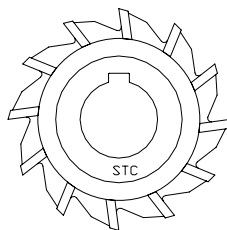

STRAIGHT TEETH

Size	Hole Diameter	Face Width
50	16	4
50	16	5
50	16	6
50	16	8
50	16	10
63	22	4
63	22	5
63	22	6
63	22	8
63	22	10
63	22	12
63	22	14
63	22	16
80	27	5
80	27	6
80	27	8
80	27	10
80	27	12
80	27	14
80	27	16
80	27	18

Size	Hole Diameter	Face Width
80	27	20
100	32	6
100	32	8
100	32	10
100	32	12
100	32	14
100	32	16
100	32	18
100	32	20
100	32	22
100	32	25
125	32	8
125	32	10
125	32	12
125	32	14
125	32	16
125	32	18
125	32	20
125	32	22
125	32	25
125	32	28

Size	Hole Diameter	Face Width
160	40	10
160	40	12
160	40	14
160	40	16
160	40	18
160	40	20
160	40	22
160	40	25
160	40	28
160	40	32
200	40	12
200	40	14
200	40	16
200	40	18
200	40	20
200	40	22
200	40	25
200	40	28
200	40	32
200	40	36
200	40	40

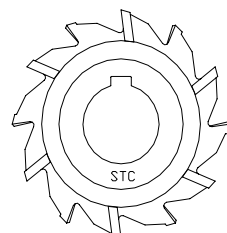

STAGGERED TEETH

## STC215A-1, HSS CONVEX CUTTER

ANSI/ASME B94.11

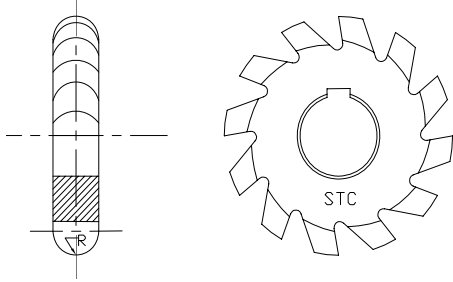

SIZE	CUTTER DIAMETER	CUTTER WIDTH	DIAMETER OF HOLE
1/8"	2-1/4"	1/8"	1"
3/16"	2-1/4"	3/16"	1"
1/4"	2-1/2"	1/4"	1"
5/16"	2-3/4"	5/16"	1"
3/8"	2-3/4"	3/8"	1"
7/16"	3"	7/16"	1"
1/2"	3"	1/2"	1"
5/8"	3-1/2"	5/8"	1-1/4"
3/4"	3-3/4"	3/4"	1-1/4"
7/8"	4"	7/8"	1-1/4"
1"	4-1/4"	1"	1-1/4"

## STC215B-1, HSS CONCAVE CUTTER

ANSI/ASME B94.19

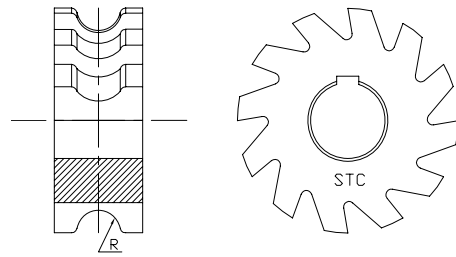

SIZE	CUTTER DIAMETER	CUTTER WIDTH	DIAMETER OF HOLE
1/8"	2-1/4"	1/4"	1"
3/16"	2-1/4"	3/8"	1"
1/4"	2-1/2"	7/16"	1"
5/16"	2-3/4"	9/16"	1"
3/8"	2-3/4"	5/8"	1"
7/16"	3"	3/4"	1"
1/2"	3"	13/16"	1"
5/8"	3-1/2"	1"	1-1/4"
3/4"	3-3/4"	1-3/16"	1-1/4"
7/8"	4"	1-3/8"	1-1/4"
1"	4-1/4"	1-9/16"	1-1/4"

## STC215A-2, HSS CONVEX CUTTER

DIN856,  
GOST9305 ALSO AVAILABLE.

SIZE	CUTTER DIAMETER	CUTTER WIDTH	DIAMETER OF HOLE
1	50	2	16
1.25		2.5	
1.6		3.2	
2		4	
2.5	63	5	22
3		6	
3.15		6.3	
4		8	
5	80	10	27
6		12	
6.3		12.6	
8		16	
10	100	20	32
12		24	
12.5		25	
16		32	
20	125	40	

## STC215B-1, HSS CONCAVE CUTTER

DIN855  
GOST9305 ALSO AVAILABLE.

SIZE	CUTTER DIAMETER	CUTTER WIDTH	DIAMETER OF HOLE
0.5	50	6	16
0.8		6	
1		6	
1.25		6	
1.6		8	
2		9	
2.5	63	10	22
3		12	
3.15		12	
4		16	
5	80	20	27
6		24	
6.3		24	
8		32	
10	100	36	32
12		40	
12.5		40	
16		50	
20	125	60	

## STC219-1, HSS SINGLE ANGLE MILLING CUTTER

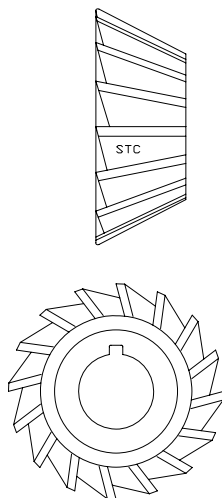

DIN842A

Angle	Diameter	Arbor Hole	Width of Face
45°	40	10	10
	50	13	13
	63	16	18
	80	22	22
	100	27	28
	125	32	36
	160	40	45
50°	40	10	13
	50	13	16
	63	16	20
	80	22	25
	100	27	32
	125	32	40
	160	40	50

DIN842A

Angle	Diameter	Arbor Hole	Width of Face
55°	40	10	13
	50	13	16
	63	16	20
	80	22	25
	100	27	32
	125	32	40
	160	40	50
60°	40	10	13
	50	13	16
	63	16	20
	80	22	25
	100	27	32
	125	32	40
	160	40	50

## STC219-2, HSS ANGLE MILLING CUTTER, DIN1823

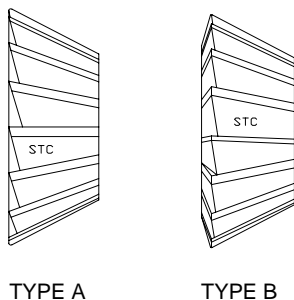

TYPE A

TYPE B

DIN1823A

Angle	Diameter	Arbor Hole	Width of Face
60°	50	16	12
	63	22	18
65°	50	16	12
70°	63	22	18
75°	50	16	12
	63	22	18
80°	63	22	18

DIN1823B

Angle	Diameter	Arbor Hole	Width of Face
60°	50	16	14
75°			16
80°			18
90°	63	22	18
60°			14
70°			18
75°			18
80°			20

## STC219-3, HSS DOUBLE ANGLE MILLING CUTTER, DIN847

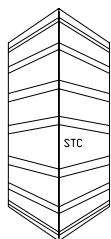

Angle	Diameter	Arbor Hole	Width of Face
45°	50	16	8
	63	22	10
	80	27	12
	100	32	18
60°	50	16	10
	63	22	14

Angle	Diameter	Arbor Hole	Width of Face
60°	80	27	18
	100	32	25
90°	50	16	14
	63	22	20
	80	27	22
	100	32	32

## STC210, HSS METAL SLITTING SAW

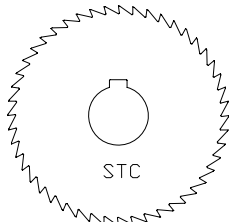

ANSI/ASMEB94.19

Cutter Dia.	Width of Face	Hole Size	No. of Teeth
1-3/4"	1/32"	1/2"	28
	1/16"		
	1/8"		
2"	1/16"	1/2"	28
	1/8"		
2-1/2"	3/64"	7/8"	28
	1/32"		
	3/64"		
	1/16"		
	3/32"		
	1/8"		
3"	1/64"	1"	30
	1/32"		
	3/64"		
	1/16"		
	5/64"		
	3/32"		
	7/64"		
	1/8"		
	9/64"		
	5/32"		
3-1/2"	1/32"	1"	30
	3/64"		
	1/16"		
	5/64"		
	3/32"		
	7/64"		
	1/8"		
	9/64"		
	5/32"		
	3/16"		
4"	1/64"	1"	36
	1/32"		
	3/64"		
	1/16"		
	5/64"		
	3/32"		
	7/64"		
	1/8"		
	9/64"		
	5/32"		
3/16"			
4-1/2"	1/32"	1"	36

## STC210MF, HSS METAL SLITTING SAW

DIN1838B, FINE TEETH  
GOST 2679-93 AVAILABLE.

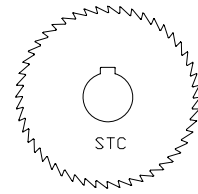

Cutter Dia.	Width of Face	Hole Size	No. of Teeth		
20	5	0.2	80		
		0.25	64		
		0.3			
		0.4			
		0.5			
		48	0.6		
			0.8		
			1	40	
			1.2		
			1.6		
			32	2	
		2.5			
		3		24	
		4			
25	8	0.2	80		
		0.25			
		0.3			
		0.4			
		64	0.5		
			0.6		
			0.8	48	
			1		
			1.2		
			1.6		
		40	2	40	
			2.5		
			3		
			32	4	
5	32				
6					
2.5	24				
3					
32	8	0.2	100		
		0.25			
		0.3	80		
		0.4			
		0.5			
		0.6			
		64	0.8	64	
			1		
			1.2		
			48	1.6	48
				2	
				2.5	64
		3			
		40	10	0.2	128
0.25					
0.3	100				
0.4					
0.5					
0.6					
32	0.8			32	
	1				
	1.2				
	40			1.6	48
				2	
				2.5	40
3					
80	22			0.2	128
		0.25			
		0.3	100		
		0.4			
		0.5			
		160		0.6	160
			0.8		
			1		
			128	1.2	80
				1.6	
				2	64
		2.5			
		100	3	64	
			4		
5					
80	6		48		
	0.3			160	
	0.4				
	0.5				
0.6					
128	0.8	128			
	1				
	100	1.2	100		
		1.6			
80	2	80			
	0.3		160		
0.4					
0.5					
0.6					
128	0.8	128			
	1				
	100	1.2	100		
		1.6			
80	2	80			
	0.3		160		
0.4					
0.5					
0.6					
128	0.8	128			
	1				
	100	1.2	100		
		1.6			
80	2	80			

## STC210MF, HSS METAL SLITTING SAW

DIN1837A, FINE TEETH

GOST 2679-93 AVAILABLE.

Cutter Dia.	Width of Face	Hole Size	No. of Teeth
80	22	2.5	80
		3	
		4	
		5	64
		6	
100		0.5	160
		0.6	
		0.8	128
		1	
		1.2	
100	22	1.6	100
		2	
		2.5	
		3	80
		4	
		5	
		6	64
125	22	0.6	160
		0.8	
		1	128
		1.2	
		1.6	
		2	100
		2.5	
		3	
		4	80
		5	
6			
160	32	1	160
		1.2	

Cutter Dia.	Width of Face	Hole Size	No. of Teeth		
160	32	1.6	160		
		2	128		
		2.5			
		3			
		4	100		
		5			
6					
200	32	1	200		
		1.2			
		1.6	160		
		2			
		2.5			
		3	128		
		4			
		5			
		6	100		
250	32	1.6	200		
		2			
		2.5	160		
		3			
		4		128	
		5			
		6			
		315	40	2	200
				2.5	
				3	
4	160				
5					
6					

## STC210MC, HSS METAL SLITTING SAW

DIN1838B, COARSE TEETH

GOST 2679-93 AVAILABLE.

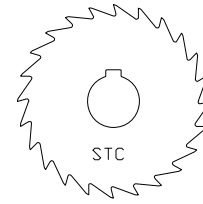

Cutter Dia.	Width of Face	Hole Size	No. of Teeth		
50	13	0.5	48		
		0.6			
		0.8	40		
		1			
		1.2			
		1.6	32		
		2			
		2.5			
		3	24		
		4			
		5	20		
		6			
		63	16	0.5	64
				0.6	48
0.8					
1	40				
1.2					
1.6					
2	32				
2.5					
3					
4	24				
5					
6					
80	22			0.6	64
				0.8	
		1	48		
		1.2			
		1.6			
		2	40		
		2.5			
		3			
		4	32		
		5			
6					
100	22	0.6	80		
		0.8			
		1	64		
		1.2			
		1.6			
		2	48		
		2.5			
		3			
		4	40		
		5			
6	32				

Cutter Dia.	Width of Face	Hole Size	No. of Teeth
125		0.8	80
		1	
		1.2	64
		1.6	
		2	
		2.5	48
		3	
		4	
		5	40
		6	
160	32	1	80
		1.2	
		1.6	64
		2	
		2.5	
3	48		
4			
160	32	6	48
		1.2	100
		1.6	
		2	80
		2.5	
		3	
		4	64
		5	
		6	
		200	32
2			
2.5	80		
3			
4			
5	64		
6			
250	32	1.6	100
		2	
		2.5	80
		3	
		4	
		5	64
6			
315	40	2	100
		2.5	
		3	80
		4	
		5	
		6	

## STC211M, HSS SCREW SLOTTING SAW

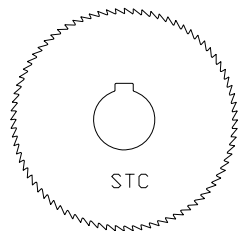

Cutter Dia.	Width of Face	Hole Size	No. of Teeth
40	13	0.25	72&90
		0.3	
		0.4	
		0.5	
		0.6	
		0.8	
		1	
60	16	0.4	60&72
		0.5	
		0.6	
		0.8	
		1	
		1.2	

Cutter Dia.	Width of Face	Hole Size	No. of Teeth
60	16	1.6	60&72
		2	
		2.5	
75	22	0.6	60&72
		0.8	
		1	
		1.2	
		1.6	
		2	
		2.5	
		3	
		4	
		5	

## STC211, HSS SCREW SLOTING SAW

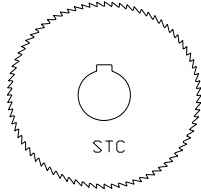

Cutter Dia.	Width of Face	Hole Size	No. of Teeth
1-3/4"	0.008"	5/8"	90
	0.010"		
	0.012"		
	0.014"		
	0.016"		
	0.018"		
	0.020"		
	0.023"		
	0.025"		
	0.028"		
	0.032"		
	0.036"		
	0.040"		
	0.045"		
	0.051"		
0.057"			
0.064"			
2-1/4"	0.010"	5/8"	60
	0.012"		
	0.014"		
	0.016"		
	0.018"		
	0.020"		
	0.023"		
	0.025"		
	0.028"		
	0.032"		
	0.036"		
	0.040"		
	0.045"		
	0.051"		
	0.057"		
0.064"			
2-3/4"	0.010"	1"	72
	0.012"		
	0.014"		
	0.016"		
	0.018"		
	0.020"		
	0.023"		
	0.025"		
	0.028"		
	0.032"		
	0.036"		
	0.040"		
	0.045"		
	0.051"		
	0.057"		
0.064"			
2-1/4"	0.045"	5/8"	60
	0.051"		
	0.057"		
	0.064"		

## STC212, JEWELERS SAWS

Cutter Dia.	Width of Face	Hole Size	No. of Teeth		
1-1/2"	0.008"	3/8"	140		
	0.010"				
	0.012"				
	0.014"				
	0.016"				
	0.018"				
	0.020"				
	0.023"				
	0.025"				
	0.028"				
0.032"					
1-3/4"	0.008"	1/2"	160		
	0.010"				
	0.012"				
	0.014"				
	0.016"				
	0.018"				
	0.020"				
	0.023"				
	0.025"				
	0.028"				
0.32"					
2"	0.008"	1/2"	190		
	0.010"				
	0.012"				
	0.014"				
	0.016"				
	0.018"				
	0.020"				
	0.023"				
	0.025"				
	0.028"				
	0.032"				
	0.035"				
	0.040"				
	0.045"				
	0.051"				
0.057"					
2-1/2"	0.010"	1/2"	240		
	0.012"				
	0.014"				
	0.016"				
	0.018"				
	0.020"				
	0.023"				
	0.025"				
	0.028"				
	0.032"				
	0.035"				
	0.040"				
	0.045"				
	0.051"				
	0.057"				
3"	0.010"	1"	280		
	0.012"				
	0.014"				
	0.016"				
	0.018"				
	0.020"				
	0.023"				
	0.025"				
	0.028"				
	3"		0.032"	1"	168
			0.035"		
			0.040"		
			0.045"		
			0.051"		
	0.057"				
4"	0.016"	1"	310		
	0.018"				
	0.020"				
	0.023"				
	0.025"				
	0.028"				
	0.032"				
	0.035"				
	0.040"				
	0.045"				
0.051"					
0.057"					
0.064"					
5"	0.025"	1"	380		
	0.028"				
	0.032"				
	0.035"				
	0.040"				
	0.045"				
	0.051"				
	0.057"				
	0.064"				
	6"		0.035"	1"	340
0.040"					
0.045"					
0.051"					
0.057"					
0.064"					

## STC212, JEWELERS SAWS

High Speed Steel.

For using in slotting. Sheeting & tubing operations.

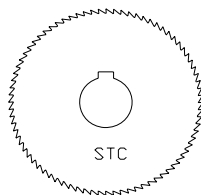

Cutter Dia.	Width of Face	Hole Size	No. of Teeth
1"	0.008"	3/8"	98
	0.010"		
	0.012"		
	0.014"		
	0.016"		
	0.018"		
	0.020"		
	0.023"		
	0.025"		
	0.028"		
0.032"			
1-1/4"	0.008"	3/8"	120
	0.010"		
	0.012"		
	0.014"		
	0.016"		
	0.018"		
	0.020"		
	0.023"		
	0.025"		
	0.028"		
0.032"			

## STC075, HAND REAMERS, DIN206

High Speed Steel, Right Hand, Alloy Steel Available.



Straight Flute

Size	Flute Length	Overall Length
1.6	21	44
1.8	23	47
2	25	50
2.2	27	54
2.5	29	58
2.8	31	62
3	31	62
3.5	35	71
4	38	76
4.5	41	81

Size	Flute Length	Overall Length
5	44	93
5.5	47	93
6	47	93
7	54	107
8	58	115
9	62	124
10	66	133
11	71	142
12	76	152
13	76	152

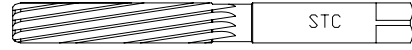

Spiral Flute

Size	Flute Length	Overall Length
14	81	163
15	81	163
16	87	175
17	87	175
18	93	188
19	93	188
20	100	201
22	107	215
25	115	231
28	124	247

Size	Flute Length	Overall Length
32	133	265
36	142	284
40	152	305
45	163	326
50	174	347
55	184	367
56	184	367
60	184	367
63	194	387
71	203	406

## STC076A, MACHINE REAMERS, Straight Shank, DIN212

High Speed Steel, Right Hand, Spiral & Straight Flute.



Straight Flute

Size	Flute Length	Overall Length
1.4	8	40
1.5	8	40
1.6	9	43
1.7	9	43
1.8	10	46
1.9	10	46
2	11	49
2.1	11	49
2.2	12	53
2.3	12	53
2.4	14	57
2.5	14	57
2.6	14	57
2.7	15	61
2.8	15	61
2.9	15	61
3	15	61
3.1	16	65
3.2	16	65
3.3	16	65
3.4	18	70
3.5	18	70
3.6	18	70
3.7	18	70
3.8	19	75
3.9	19	75
4	19	75
4.1	19	75
4.2	19	75

Size	Flute Length	Overall Length
4.3	21	80
4.4	21	80
4.5	21	80
4.6	21	80
4.7	21	80
4.8	23	86
4.9	23	86
5	23	86
5.1	23	86
5.2	23	86
5.3	23	86
5.4	26	93
5.5	26	93
5.6	26	93
5.7	26	93
5.8	26	93
5.9	26	93
6	26	93
6.1	28	101
6.2	28	101
6.3	28	101
6.4	28	101
6.5	28	101
6.6	28	101
6.7	28	101
6.8	31	109
6.9	31	109
7	31	109
7.1	31	109

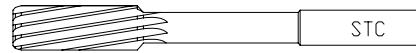

Spiral Flute

Size	Flute Length	Overall Length
7.2	31	109
7.3	31	109
7.4	31	109
7.5	31	109
7.6	33	109
7.7	33	109
7.8	33	109
7.9	33	109
8	33	109
8.1	33	109
8.2	33	109
8.3	33	109
8.4	33	109
8.5	33	109
8.6	36	125
8.7	36	125
8.8	36	125
8.9	36	125
9	36	125
9.1	36	125
9.2	36	125
9.3	36	125
9.4	36	125
9.5	36	125
9.6	38	133
9.7	38	133
9.8	38	133
9.9	38	133
10	38	133

Size	Flute Length	Overall Length
10.1	38	133
10.2	38	133
10.3	38	133
10.4	38	133
10.5	38	133
10.6	38	133
10.7	41	141
10.8	41	141
10.9	41	141
11	41	141
11.1	41	141
11.2	41	141
11.3	41	141
11.4	41	141
11.5	41	141
11.6	41	141
11.7	41	141
11.8	41	141
11.9	44	151
12	44	151
12.5	44	151
13	44	151
14	47	160
15	50	162
16	52	170
17	54	175
18	56	182
19	58	189
20	60	195

## STC223-1, HSS CHUCKING REAMER, ANSI/ASME94B.11

High Speed Steel, Straight Shank, Right Hand Cutting, 45° Chamfered Cutting Edges.



Straight Flute



Spiral Flute, Right Hand

### Fractional Sizes

Size	Flute Length	Overall Length
3/64"	1/2"	2-1/2"
1/16"	1/2"	2-1/2"
5/64"	3/4"	3"
3/32"	3/4"	3"
7/64"	7/8"	3-1/2"
1/8"	7/8"	3-1/2"
9/64"	1"	4"
5/32"	1"	4"
11/64"	1-1/8"	4-1/2"
3/16"	1-1/8"	4-1/2"
13/64"	1-1/4"	5"
7/32"	1-1/4"	5"
15/64"	1-1/2"	6"
1/4"	1-1/2"	6"
17/64"	1-1/2"	6"
9/32"	1-1/2"	6"
19/64"	1-1/2"	6"
5/16"	1-1/2"	6"
21/64"	1-1/2"	6"

Size	Flute Length	Overall Length
11/32"	1-1/2"	6"
23/64"	1-3/4"	7"
3/8"	1-3/4"	7"
25/64"	1-3/4"	7"
13/32"	1-3/4"	7"
27/64"	1-3/4"	7"
7/16"	1-3/4"	7"
29/64"	1-3/4"	7"
15/32"	1-3/4"	7"
31/64"	2"	8"
1/2"	2"	8"
33/64"	2"	8"
17/32"	2"	8"
35/64"	2"	8"
9/16"	2"	8"
37/64"	2"	8"
19/32"	2"	8"
39/64"	2-1/4"	9"
5/8"	2-1/4"	9"

Size	Flute Length	Overall Length
41/64"	2-1/4"	9"
21/32"	2-1/4"	9"
43/64"	2-1/4"	9"
11/16"	2-1/4"	9"
45/64"	2-1/4"	9"
23/32"	2-1/4"	9"
47/64"	2-1/4"	9"
3/4"	2-1/2"	9-1/2"
49/64"	2-1/2"	9-1/2"
15/16"	2-1/2"	9-1/2"
51/64"	2-1/2"	9-1/2"
13/16"	2-1/2"	9-1/2"
53/64"	2-1/2"	9-1/2"
27/32"	2-1/2"	9-1/2"
55/64"	2-1/2"	9-1/2"
7/8"	2-5/8"	10"
57/64"	2-5/8"	10"
29/32"	2-5/8"	10"
59/64"	2-5/8"	10"

Size	Flute Length	Overall Length
15/16"	2-5/8"	10"
61/64"	2-5/8"	10"
31/32"	2-5/8"	10"
63/64"	2-5/8"	10"
1"	2-3/4"	10-1/2"
1-1/32"	2-3/4"	10-1/2"
1-1/16"	2-3/4"	10-1/2"
1-3/32"	2-3/4"	10-1/2"
1-1/8"	2-7/8"	11"
1-5/32"	2-7/8"	11"
1-3/16"	2-7/8"	11"
1-7/32"	2-7/8"	11"
1-1/4"	3"	11-1/2"
1-5/16"	3"	11-1/2"
1-3/8"	3-1/4"	12"
1-7/16"	3-1/4"	12"
1-1/2"	3-1/2"	12-1/2"

### Letter Sizes

Size	Flute Length	Overall Length
A	1-1/2"	6"
B	1-1/2"	6"
C	1-1/2"	6"
D	1-1/2"	6"
E	1-1/2"	6"
F	1-1/2"	6"
G	1-1/2"	6"

Size	Flute Length	Overall Length
H	1-1/2"	6"
I	1-1/2"	6"
J	1-1/2"	6"
K	1-1/2"	6"
L	1-1/2"	6"
M	1-1/2"	6"
N	1-1/2"	6"

Size	Flute Length	Overall Length
O	1-1/2"	6"
P	1-1/2"	6"
Q	1-1/2"	6"
R	1-1/2"	6"
S	1-3/4"	7"
T	1-3/4"	7"
U	1-3/4"	7"

Size	Flute Length	Overall Length
V	1-3/4"	7"
W	1-3/4"	7"
X	1-3/4"	7"
Y	1-3/4"	7"
Z	1-3/4"	7"

### Wire Gauge Sizes

Size	Flute Length	Overall Length
60	1/2"	2-1/2"
59	1/2"	2-1/2"
58	1/2"	2-1/2"
57	1/2"	2-1/2"
56	1/2"	2-1/2"
55	1/2"	2-1/2"
54	1/2"	2-1/2"
53	1/2"	2-1/2"
52	1/2"	2-1/2"
51	3/4"	3"
50	3/4"	3"
49	3/4"	3"
48	3/4"	3"
47	3/4"	3"
46	3/4"	3"

Size	Flute Length	Overall Length
45	3/4"	3"
44	3/4"	3"
43	3/4"	3"
42	3/4"	3"
41	7/8"	3-1/2"
40	7/8"	3-1/2"
39	7/8"	3-1/2"
38	7/8"	3-1/2"
37	7/8"	3-1/2"
36	7/8"	3-1/2"
35	7/8"	3-1/2"
34	7/8"	3-1/2"
33	7/8"	3-1/2"
32	7/8"	3-1/2"
31	7/8"	3-1/2"

Size	Flute Length	Overall Length
30	7/8"	3-1/2"
29	1"	4"
28	1"	4"
27	1"	4"
26	1"	4"
25	1"	4"
24	1"	4"
23	1"	4"
22	1"	4"
21	1-1/8"	4-1/2"
20	1-1/8"	4-1/2"
19	1-1/8"	4-1/2"
18	1-1/8"	4-1/2"
17	1-1/8"	4-1/2"
16	1-1/8"	4-1/2"

Size	Flute Length	Overall Length
15	1-1/8"	4-1/2"
14	1-1/8"	4-1/2"
13	1-1/8"	4-1/2"
12	1-1/8"	4-1/2"
11	1-1/4"	5"
10	1-1/4"	5"
9	1-1/4"	5"
8	1-1/4"	5"
7	1-1/4"	5"
6	1-1/4"	5"
5	1-1/4"	5"
4	1-1/4"	5"
3	1-1/4"	5"
2	1-1/2"	6"
1	1-1/2"	6"

## STC223-1, HSS HAND REAMERS, INCH SIZE

High Speed Steel, Right Hand, Spiral & Straight Flute.

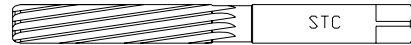

Size	Flute Length	Overall Length
1/8"	1-1/2"	3"
9/64"	1-5/8"	3-1/4"
5/32"	1-5/8"	3-1/4"
11/64"	1-3/4"	3-1/2"
3/16"	1-3/4"	3-1/2"
13/64"	1-7/8"	3-3/4"
7/32"	1-7/8"	3-3/4"
15/64"	2"	4"
1/4"	2"	4"
17/64"	2-1/8"	4-1/4"
9/32"	2-1/8"	4-1/4"

Size	Flute Length	Overall Length
19/64"	2-1/4"	4-1/2"
5/16"	2-1/4"	4-1/2"
11/32"	2-3/8"	4-3/4"
3/8"	2-1/2"	5"
13/32"	2-5/8"	5-1/4"
7/16"	2-3/4"	5-1/2"
15/32"	2-7/8"	5-3/4"
1/2"	3"	6"
17/32"	3-1/8"	6-1/4"
9/16"	3-1/4"	6-1/2"
19/32"	3-3/8"	6-3/4"

Size	Flute Length	Overall Length
5/8"	3-1/2"	7"
21/32"	3-11/16"	7-3/8"
11/16"	3-7/8"	7-3/4"
23/32"	4-1/16"	8-1/8"
3/4"	4-3/16"	8-3/8"
25/32"	4-3/8"	8-3/4"
13/16"	4-9/16"	9-1/8"
27/32"	4-11/16"	9-3/8"
7/8"	4-7/8"	9-3/4"
29/32"	5"	10"
15/16"	5-1/8"	10-1/4"

Size	Flute Length	Overall Length
31/32"	5-5/16"	10-5/8"
1"	5-7/16"	10-7/8"
1-1/16"	5-5/8"	11-1/4"
1-1/8"	5-13/16"	11-5/8"
1-3/16"	6"	12"
1-1/4"	6-1/8"	12-1/4"
1-5/16"	6-1/4"	12-1/2"
1-3/8"	6-5/16"	12-5/8"
1-7/16"	6-7/16"	12-7/8"
1-1/2"	6-1/2"	13"

## STC229-2, CARBIDE TIPPED MACHINE REAMERS

Straight Shank, Right Hand, Straight Flute.

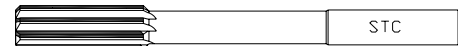

Size	Flute Length	Overall Length
6	36	93
7	40	109
8	42	117
9	44	125

Size	Flute Length	Overall Length
10	46	133
11	46	142
12	46	151
13	46	151

Size	Flute Length	Overall Length
14	50	160
15	50	162
16	50	170
17	52	175

Size	Flute Length	Overall Length
18	52	182
19	58	189
20	58	195

## STC229-1, CARBIDE TIPPED CHUCK REAMERS

Straight Shank, Right Hand, Straight Flute.

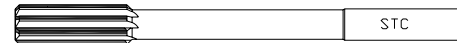

Size	Flute Length	Overall Length
3/16"	1-1/8"	4-1/2"
7/32"	1-1/4"	5"
1/4"	1-1/2"	6"
9/32"	1-1/2"	6"
5/16"	1-1/2"	6"
11/32"	1-1/2"	6"
3/8"	1-3/4"	7"
13/32"	1-3/4"	7"
7/16"	1-3/4"	7"

Size	Flute Length	Overall Length
15/32"	1-3/4"	7"
1/2"	2"	8"
17/32"	2"	8"
9/16"	2"	8"
19/32"	2"	8"
5/8"	2-1/4"	9"
21/32"	2-1/4"	9"
11/16"	2-1/4"	9"
23/32"	2-1/4"	9"

Size	Flute Length	Overall Length
3/4"	2-1/2"	9-1/2"
25/32"	2-1/2"	9-1/2"
13/16"	2-1/2"	9-1/2"
27/32"	2-1/2"	9-1/2"
7/8"	2-5/8"	10"
29/32"	2-5/8"	10"
15/16"	2-5/8"	10"
31/32"	2-5/8"	10"
1"	2-3/4"	10-1/2"

Size	Flute Length	Overall Length
1-1/16"	2-3/4"	10-1/2"
1-1/8"	2-7/8"	11"
1-3/16"	2-7/8"	11"
1-1/4"	3"	11-1/2"
1-5/16"	3"	11-1/2"
1-3/8"	3-1/4"	12"
1-7/16"	3-1/4"	12"
1-1/2"	3-1/2"	12-1/2"

## STC224, EXPANSION HAND REAMERS, DIN859

Straight Shank, Right Hand Cutting, Straight & Spiral Flute.



Size	Flute Length	Overall Length
6	47	93
7	54	107
8	58	115
9	62	124
10	66	133
11	71	142

Size	Flute Length	Overall Length
12	76	152
13	76	152
14	81	163
15	81	163
16	93	175
17	93	175

Size	Flute Length	Overall Length
18	93	188
19	93	188
20	100	201
21	100	201
22	107	201
23	107	201

Size	Flute Length	Overall Length
24	115	231
25	115	231
30	124	247

## STC077A, EXPANSION HAND REAMERS

Straight Shank, Right Hand Cutting, Straight & Spiral Flute.



Size	Flute Length	Overall Length
1/4"	1-1/2"	4"
9/32"	1-1/2"	4"
5/16"	1-1/2"	4"
11/32"	1-1/2"	4"
3/8"	2"	5"
13/32"	2"	5"
7/16"	2"	5"
15/32"	2"	5"

Size	Flute Length	Overall Length
1/2"	2"	5-1/2"
17/32"	2"	5-1/2"
9/16"	2-1/2"	6"
19/32"	2-1/2"	6"
5/8"	3"	7"
21/32"	3"	7"
11/16"	3"	7"
23/32"	3"	7"

Size	Flute Length	Overall Length
3/4"	3-1/2"	8"
25/32"	3-1/2"	8"
13/16"	3-1/2"	8"
27/32"	3-1/2"	8"
7/8"	4"	9"
29/32"	4"	9"
15/16"	4"	9"
31/32"	4"	9"

Size	Flute Length	Overall Length
1"	4-1/2"	10"
1-1/16"	4-1/2"	10"
1-1/8"	4-3/4"	10-1/2"
1-3/16"	4-3/4"	10-1/2"
1-1/4"	5"	11"
1-5/16"	5"	11"
1-3/8"	5-1/4"	11-1/2"
1-1/2"	5-1/2"	12"

## STC225, ADJUSTABLE HAND REAMERS

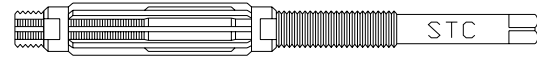

Size	No. of Blade	Reaming Range	Flute Length	Overall Length
8A	4	1/4" to 9/32"	1-5/8"	3-1/2"
7A	4	9/32" to 5/16"	1-5/8"	3-3/4"
6A	4	5/16" to 11/32"	1-5/8"	4"
5A	4	11/32" to 3/8"	1-7/8"	4-1/4"
4A	4	3/8" to 13/32"	1-7/8"	4-1/2"
3A	6	13/32" to 7/16"	1-7/8"	4-3/4"
2A	6	7/16" to 15/16"	1-7/8"	5"
A	6	15/16" to 17/32"	2"	5-1/4"
B	6	17/32" to 19/32"	2"	5-3/4"
C	7	19/32" to 21/32"	2-1/4"	6-1/4"
D	7	21/32" to 23/32"	2-1/4"	6-3/4"

Size	No. of Blade	Reaming Range	Flute Length	Overall Length
E	7	23/32" to 25/32"	2-1/2"	7-1/4"
F	7	25/32" to 27/32"	2-1/2"	7-3/4"
G	7	27/32" to 15/16"	3"	8-1/4"
H	7	15/16" to 1-1/16"	3"	8-3/4"
I	7	1-1/16" to 1-3/16"	3-1/2"	10"
J	7	1-3/16" to 1-11/32"	3-1/2"	11"
K	7	1-11/32" to 1-1/2"	4"	12"
L	7	1-1/2" to 1-13/16"	4"	13"
M	7	1-13/16" to 2-7/32"	5-1/4"	15"
N	7	2-7/32" to 2-3/4"	5-3/4"	17"
O	7	2-3/4" to 3-11/32"	6-1/2"	19"

## STC225M, ADJUSTABLE HAND REAMERS

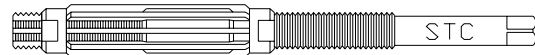

Shank Diameter	No. of Blade	Reaming Range	Flute Length	Overall Length
4	5	6.5 – 7	35	85
4	5	7 – 7.75	35	90
4.8	5	7.75 – 8.5	38	100
4.8	5	8.5 – 9.25	38	105
5.6	6	9.25 – 10	38	115
5.6	6	10 – 10.75	38	125
6.3	6	10.75 – 11.75	38	130
7.1	6	11.75 – 12.75	44	135
7.1	6	12.75 – 13.75	48	145
8	6	13.75 – 15.25	52	150
9	6	15.25 – 17	55	165
10	6	17 – 19	60	170

Shank Diameter	No. of Blade	Reaming Range	Flute Length	Overall Length
11.2	6	19 – 21	60	180
14	6	21 – 23	65	195
14	6	23 – 26	72	215
18	6	26 – 29.5	80	240
19.8	6	29.5 – 33.5	85	270
19.8	6	33.5 – 38	95	310
25	6	38 – 44	105	350
31.5	6	44 – 54	120	400
40	6	54 – 63	120	460
50	6	63 – 84	135	530
63	8	84 – 100	140	570

## STC077C, MORSE TAPER REAMERS

High Speed Steel, Square Shank, Hand Use

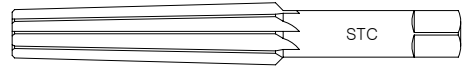

Size	Overall Length	Flute Length	Small End Diameter	Large End Diameter
MT0	3-3/4"	2-1/4"	0.2503	0.3674
MT1	5"	3"	0.3674	0.517
MT2	6"	3-1/2"	0.5696	0.7444
MT3	7-1/4"	4-1/4"	0.7748	0.9881
MT4	8-1/2"	5-1/4"	1.0167	1.2893
MT5	9-3/4"	6-1/4"	1.4717	1.8005

Size	Overall Length	Flute Length	Small End Diameter	Large End Diameter
MT0	93	61	6.547	9.722
MT1	102	66	9.571	12.863
MT2	121	79	14.733	18.679
MT3	146	96	20.01	24.829
MT4	179	119	26.229	32.41
MT5	222	150	37.873	45.767
MT6	300	208	54.171	65.016

## STC080, NPT TAPER PIPE REAMERS

High Speed Steel, Square Shank, Spiral & Straight Flute. Taper 3/4" per foot.

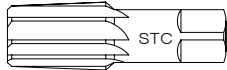

NPT Size	Large End Diameter	Small End Diameter	Flute Length	Overall Length
1/8"	0.362"	0.316"	3/4"	2-1/8"
1/4"	0.472"	0.406"	1-1/16"	2-7/16"
3/8"	0.606"	0.540"	1-1/16"	2-9/16"
1/2"	0.751"	0.665"	1-3/8"	3-1/8"
3/4"	0.962"	0.876"	1-3/8"	3-1/4"

NPT Size	Large End Diameter	Small End Diameter	Flute Length	Overall Length
1"	1.212"	1.103"	1-3/4"	3-3/4"
1-1/4"	1.553"	1.444"	1-3/4"	4"
1-1/2"	1.793"	1.684"	1-3/4"	4-1/4"
2"	2.268"	2.159"	1-3/4"	4-1/2"
2-1/2"	2.722"	2.561"	2-9/16"	5-1/2"

## STC227, TAPER PIN REAMERS

High Speed Steel, Square Shank, Spiral & Straight Flute. Right Hand Cutting. Taper 1/4" per foot.



Size	Small End Diameter	Large End Diameter	Flute Length	Overall Length
7/0	0.0497"	0.0666"	13/16"	1-13/16"
6/0	0.0611"	0.0806"	15/16"	1-15/16"
5/0	0.0719"	0.0966"	1-3/16"	2-3/16"
4/0	0.0869"	0.1142"	1-5/16"	2-5/16"
3/0	0.1029"	0.1302"	1-9/16"	2-5/16"
2/0	0.1137"	0.1462"	1-9/16"	2-9/16"
0	0.1287"	0.1638"	1-11/16"	2-15/16"
1	0.1447"	0.1798"	1-11/16"	2-15/16"
2	0.1605"	0.2008"	1-15/16"	3-3/16"
3	0.1813"	0.2294"	2-5/16"	3-11/16"
4	0.2071"	0.2604"	2-9/16"	4-1/16"

Size	Small End Diameter	Large End Diameter	Flute Length	Overall Length
5	0.2409"	0.2994"	2-13/16"	4-5/16"
6	0.2773"	0.3540"	3-11/16"	5-7/16"
7	0.3297"	0.4220"	4-7/16"	6-5/16"
8	0.3971"	0.5050"	5-3/16"	7-3/16"
9	0.4805"	0.6066"	6-1/16"	8-5/16"
10	0.5799"	0.7216"	6-13/16"	9-5/16"
11	0.7060"	0.8780"	8-1/4"	11-1/4"
12	0.8420"	1.0500"	10"	13-5/8"
13	1.0090"	1.2590"	12"	16"
14	1.2500"	1.5420"	14"	18-1/4"

## STC227M, HAND 1:50 TAPER PIN REAMERS

High Speed Steel, Straight Shank, Spiral & Straight Flute. Right Hand Cutting.



Size	Small End Diameter	Large End Diameter	Flute Length	Overall Length
1.5	1.4	2.14	37	57
2	1.9	2.86	48	68
2.5	2.4	3.36	48	68
3	2.9	4.06	58	80
4	3.9	5.26	68	93
5	4.9	6.36	73	100
6	5.9	8	105	135
6.5	6.4	8.6	110	140

Size	Small End Diameter	Large End Diameter	Flute Length	Overall Length
7	6.9	9.4	125	160
8	7.9	10.8	145	180
9	8.9	12.1	160	195
10	9.9	13.4	175	215
12	11.8	16	210	255
13	12.8	17	210	255
16	15.8	20.4	230	280
20	19.8	24.8	250	310

## STC220, HSS TAPER SHANK MACHINE REAMERS, DIN208



STRAIGHT FLUTE

Size	Flute Length	Overall Length	Morse Taper
6	26	138	1
7	31	150	1
8	33	156	1
9	36	162	1
10	38	168	1
11	41	175	1
12	44	182	1
13	44	182	1
14	47	189	1
15	50	204	2
16	52	210	2



SPIRAL FLUTE

Size	Flute Length	Overall Length	Morse Taper
34	78	321	4
35	78	321	4
36	79	325	4
38	81	329	4
40	81	329	4
42	82	333	4
44	83	336	4
45	83	336	4
46	84	340	4
48	86	344	4
50	86	344	4

## STC076-T, HSS TAPER SHANK CHUCK REAMERS

HIGH SPEED STEEL, RIGHT HAND, SPIRAL & STRAIGHT FLUTE.



STRAIGHT FLUTE

Size	Flute Length	Overall Length	Morse Taper
1/4"	1-1/2"	6"	MT1
9/32"	1-1/2"	6"	MT1
5/16"	1-1/2"	6"	MT1
11/32"	1-1/2"	6"	MT1
3/8"	1-3/4"	7"	MT1
13/32"	1-3/4"	7"	MT1
7/16"	1-3/4"	7"	MT1
15/32"	1-3/4"	7"	MT1
1/2"	2"	8"	MT1
17/32"	2"	8"	MT1
9/16"	2"	8"	MT1
19/32"	2"	8"	MT1
5/8"	2-1/4"	9"	MT2



SPIRAL FLUTE

Size	Flute Length	Overall Length	Morse Taper
21/32"	2-1/4"	9"	MT2
11/16"	2-1/4"	9"	MT2
23/32"	2-1/4"	9"	MT2
3/4"	2-1/2"	9-1/2"	MT2
25/32"	2-1/2"	9-1/2"	MT2
13/16"	2-1/2"	9-1/2"	MT2
27/32"	2-1/2"	9-1/2"	MT2
7/8"	2-5/8"	10"	MT2
29/32"	2-5/8"	10"	MT2
15/16"	2-5/8"	10"	MT3
31/32"	2-5/8"	10"	MT3
1"	2-3/4"	10-1/2"	MT3
1-1/16"	2-3/4"	10-1/2"	MT3

Size	Flute Length	Overall Length	Morse Taper
1-1/8"	2-7/8"	11"	MT3
1-3/16"	2-7/8"	11"	MT3
1-1/4"	3"	11-1/2"	MT4
1-5/16"	3"	11-1/2"	MT4
1-3/8"	3-1/4"	12"	MT4
1-7/16"	3-1/4"	12"	MT4
1-1/2"	3-1/2"	12-1/2"	MT4
1-9/16"	3-1/2"	12-1/2"	MT4
1-5/8"	3-1/2"	13"	MT4
1-3/4"	4"	13-1/2"	MT4
1-7/8"	4"	14"	MT4
2"	4"	14-1/2"	MT4

## STC229-3, CARBIDE TIPPED CHUCK REAMERS

Taper Shank, Right Hand, Straight Flute.

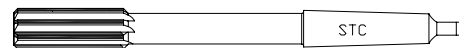

Size	Flute Length	Overall Length	Morse Taper
1/4"	1-1/2"	6"	MT1
9/32"	1-1/2"	6"	MT1
5/16"	1-1/2"	6"	MT1
11/32"	1-1/2"	6"	MT1
3/8"	1-3/4"	7"	MT1
13/32"	1-3/4"	7"	MT1
7/16"	1-3/4"	7"	MT1
15/32"	1-3/4"	7"	MT1
1/2"	2"	8"	MT1
17/32"	2"	8"	MT1
9/16"	2"	8"	MT1
19/32"	2"	8"	MT1
5/8"	2-1/4"	9"	MT2

Size	Flute Length	Overall Length	Morse Taper
21/32"	2-1/4"	9"	MT2
11/16"	2-1/4"	9"	MT2
23/32"	2-1/4"	9"	MT2
3/4"	2-1/2"	9-1/2"	MT2
25/32"	2-1/2"	9-1/2"	MT2
13/16"	2-1/2"	9-1/2"	MT2
27/32"	2-1/2"	9-1/2"	MT2
7/8"	2-5/8"	10"	MT2
29/32"	2-5/8"	10"	MT2
15/16"	2-5/8"	10"	MT3
31/32"	2-5/8"	10"	MT3
1"	2-3/4"	10-1/2"	MT3
1-1/16"	2-3/4"	10-1/2"	MT3

Size	Flute Length	Overall Length	Morse Taper
1-1/8"	2-7/8"	11"	MT3
1-3/16"	2-7/8"	11"	MT3
1-1/4"	3"	11-1/2"	MT4
1-5/16"	3"	11-1/2"	MT4
1-3/8"	3-1/4"	12"	MT4
1-7/16"	3-1/4"	12"	MT4
1-1/2"	3-1/2"	12-1/2"	MT4
1-9/16"	3-1/2"	12-1/2"	MT4
1-5/8"	3-1/2"	13"	MT4
1-3/4"	4"	13-1/2"	MT4
1-7/8"	4"	14"	MT4
2"	4"	14-1/2"	MT4

## STC220-4, CARBIDE TIPPED MACHINE REAMERS, TAPER SHANK

Taper Shank, Right Hand, Straight Flute.

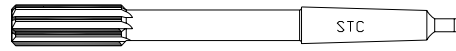

Size	Flute Length	Overall Length	Morse Taper
6	26	138	1
7	31	150	1
8	33	156	1
9	36	162	1
10	38	168	1
11	41	175	1
12	44	182	1
13	44	182	1
14	47	189	1
15	50	204	2
16	52	210	2

Size	Flute Length	Overall Length	Morse Taper
17	54	214	2
18	56	219	2
19	58	223	2
20	60	228	2
22	64	237	2
24	68	268	3
25	68	268	3
26	70	273	3
28	71	281	3
30	73	277	3
32	77	281	4

Size	Flute Length	Overall Length	Morse Taper
34	78	321	4
35	78	321	4
36	79	325	4
38	81	329	4
40	81	329	4
42	82	333	4
44	83	336	4
45	83	336	4
46	84	340	4
48	86	344	4
50	86	344	4

## STC077B, BRIDGE REAMERS

High Speed Steel, Taper Shank, Left Hand Spiral & Straight Flute. Right Hand Cutting,

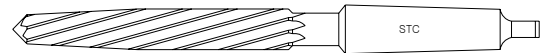
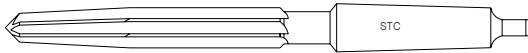

Size	Flute Length	Overall Length	Morse Taper
3/8"	3-3/4"	7-3/4"	MT1
13/32"	4-3/8"	8-1/4"	MT2
7/16"	4-3/8"	8-1/4"	MT2
15/32"	5-1/8"	9"	MT2
1/2"	5-1/8"	9"	MT2
17/32"	5-1/8"	9"	MT2
9/16"	5-1/8"	9"	MT2
5/8"	6-1/8"	10"	MT2

Size	Flute Length	Overall Length	Morse Taper
11/16"	7-1/8"	11-3/4"	MT3
3/4"	7-3/8"	12"	MT3
13/16"	7-3/8"	12"	MT3
7/8"	7-3/8"	12"	MT3
15/16"	7-3/8"	12"	MT3
1"	7-3/8"	12"	MT3
1-1/16"	7-3/8"	12"	MT3
1-1/8"	7-3/8"	12"	MT3

Size	Flute Length	Overall Length	Morse Taper
1-3/16"	7-3/8"	12"	MT3
1-1/4"	7-3/8"	13"	MT4
1-5/16"	7-3/8"	13"	MT4
1-3/8"	7-3/8"	13"	MT4
1-7/16"	7-3/8"	13"	MT4
1-1/2"	7-3/8"	13"	MT4

## STC077BM, BRIDGE REAMERS

High Speed Steel, Taper Shank, Left Hand Spiral & Straight Flute. Right Hand Cutting,



Size	Flute Length	Overall Length	Morse Taper
6.4	75	151	1
7.4	80	156	1
8	85	161	1
8.4	85	161	1
9	90	166	1
9.5	90	166	1
10	95	171	1
11	100	176	1
12	105	199	2
13	105	199	2
14	115	209	2
15	125	229	2
16	135	251	2

Size	Flute Length	Overall Length	Morse Taper
17	135	251	3
18	145	261	3
19	145	261	3
20	155	271	3
21	155	271	3
22	165	281	3
23	165	281	3
24	180	296	3
25	180	296	3
26	180	296	3
27	195	311	3
28	195	311	3
29	195	311	3

Size	Flute Length	Overall Length	Morse Taper
30	195	311	3
31	210	326	3
32	210	354	4
33	210	354	4
34	220	364	4
35	220	364	4
36	220	364	4
37	220	364	4
38	230	374	4
39	230	374	4
40	230	374	4

## STC078-1, HSS SHELL REAMERS

STANDARD: ANSI/ASME 94B.19  
STRAIGHT & HELICAL FLUTE

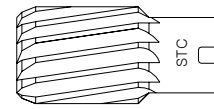
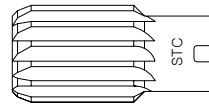

Size	Overall Length	Arbor Diameter	Fitting Arbor No.
3/4"	2-1/4"	3/8"	4
13/16"	2-1/2"	1/2"	5
7/8"	2-1/2"	1/2"	5
15/16"	2-1/2"	1/2"	5
1"	2-1/2"	1/2"	5
1-1/16"	2-3/4"	5/8"	6
1-1/8"	2-3/4"	5/8"	6
1-3/16"	2-3/4"	5/8"	6
1-1/4"	2-3/4"	5/8"	6
1-5/16"	3"	3/4"	7
1-3/8"	3"	3/4"	7
1-7/16"	3"	3/4"	7
1-1/2"	3"	3/4"	7

Size	Overall Length	Arbor Diameter	Fitting Arbor No.
1-9/16"	3"	3/4"	7
1-5/8"	3"	3/4"	7
1-11/16"	3-1/2"	1"	8
1-3/4"	3-1/2"	1"	8
1-13/16"	3-1/2"	1"	8
1-7/8"	3-1/2"	1"	8
1-15/16"	3-1/2"	1"	8
2"	3-1/2"	1"	8
2-1/16"	3-3/4"	1-1/4"	9
2-1/8"	3-3/4"	1-1/4"	9
2-3/16"	3-3/4"	1-1/4"	9
2-1/4"	3-3/4"	1-1/4"	9
2-5/16"	3-3/4"	1-1/4"	9

Size	Overall Length	Arbor Diameter	Fitting Arbor No.
2-3/8"	3-3/4"	1-1/4"	9
2-7/16"	3-3/4"	1-1/4"	9
2-1/2"	3-3/4"	1-1/4"	9
2-9/16"	4"	1-1/2"	10
2-5/8"	4"	1-1/2"	10
2-11/16"	4"	1-1/2"	10
2-3/4"	4"	1-1/2"	10
2-13/16"	4"	1-1/2"	10
2-7/8"	4"	1-1/2"	10
2-15/16"	4"	1-1/2"	10
3"	4"	1-1/2"	10

## STC078-2, SHELL REAMERS

Size	Overall Length	Arbor Diameter	Fitting Arbor No.
20	40	10	A, C
21	40	10	A, C
22	40	10	A, C
23	40	10	A, C
24	45	13	B, D
25	45	13	B, D
26	45	13	B, D
27	45	13	B, D

Size	Overall Length	Arbor Diameter	Fitting Arbor No.
28	45	13	B, D
29	45	13	B, D
30	45	13	B, D
32	50	16	E
35	50	16	E
36	56	19	F, G
38	56	19	F, G
40	56	19	F, G

Size	Overall Length	Arbor Diameter	Fitting Arbor No.
42	56	19	F, G
45	63	22	H
48	63	22	H
50	63	22	H
52	71	27	I
55	71	27	I
60	71	27	I

## STC078-1, SHELL REAMER ARBOR, Inch Sizes

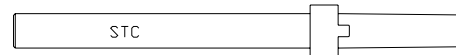

TAPER SHANK					STRAIGHT SHANK				
Size	M.T. Shank	Arbor Diameter	Fits shell reamers	Overall Length	Size	Fits shell Reamers	Shank Diameter	Arbor Diameter	Overall Length
4	MT 2	3/8"	21/32" - 25/32"	9"	4	21/32" - 25/32"	1/2"	3/8"	9"
5	MT 2	1/2"	13/16" - 1-1/32"	9-1/2"	5	13/16" - 1-1/32"	5/8"	1/2"	9-1/2"
6	MT 3	5/8"	1.1/16" - 1-9/32"	10"	6	1.1/16" - 1-9/32"	3/4"	5/8"	10"
7	MT 3	3/4"	1.5/16" - 1-5/8"	11"	7	1.5/16" - 1-5/8"	7/8"	3/4"	11"
8	MT 3	1"	1.11/16" - 2"	12"	8	1.11/16" - 2"	1-1/8"	1"	12"
9	MT 4	1-1/4"	2.1/16" - 2-1/2"	13"	9	2.1/16" - 2-1/2"	1-3/8"	1-1/4"	13"
10	MT 5	1-1/2"	2.9/16" - 3"	14"	10	2.9/16" - 3"	1-5/8"	1-1/2"	14"

## STC078-2, SHELL REAMER ARBOR, Taper Shank, DIN217

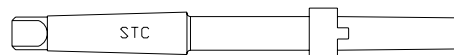

Size	M.T. Shank	Arbor Diameter	Fits Shell Reamers	Total Length
A	MT2	10	20 - 23	255
B	MT2	13	24 - 30	250
C	MT3	10	20 - 23	250
D	MT3	13	24 - 30	250
E	MT3	16	32 - 35	261
F	MT3	19	36 - 42	273

Size	M.T. Shank	Arbor Diameter	Fits Shell Reamers	Total Length
G	MT 4	19	36 - 42	298
H	MT 4	22	45 - 50	312
I	MT 4	27	52 - 60	327
J	MT 5	32	60 - 90	376
K	MT 5	40	71 - 100	396

## STC075R, HAND REAMER

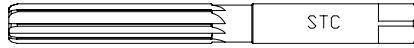

GOST 7722

STRAIGHT SHANK

Size	Flute Length	Overall Length	Size	Flute Length	Overall Length
1.8	23	47	17	87	175
2	25	50	18	93	188
2.2	27	54	19		
2.5	29	58	20	100	201
2.8	31	62	21		
3			107	215	
3.2					
3.4					
3.5	35	71	22	115	231
3.6					
3.8					
4					
4.2	38	76	23	124	247
4.5					
4.8	41	81	24	133	265
5					
5.2	44	87	25	142	284
5.5					
6	47	93	26	152	305
6.3					
6.5					
7					
7.5	54	107	27	163	326
8					
8.5	58	115	28	174	347
9					
9.5	62	124	29	184	367
10					
10.5	66	133	30	194	387
11					
11.5					
12					
12	76	152	31	203	406
13					
14	81	163	32		
15					
16	87	175	33		
			34		
			35		
			36		
			37		
			38		
			39		
			40		
			41		
			42		
			43		
			44		
			45		
			46		
			47		
			48		
			49		
			50		
			51		
			52		
			53		
			54		
			55		
			56		
			57		
			58		
			59		
			60		
			61		
			62		
			63		
			64		
			65		
			66		
			67		
			68		
			69		
			70		
			71		
			72		
			73		
			74		
			75		
			76		
			77		
			78		
			79		
			80		
			81		
			82		
			83		
			84		
			85		
			86		
			87		
			88		
			89		
			90		
			91		
			92		
			93		
			94		
			95		
			96		
			97		
			98		
			99		
			100		

## STC075R, MACHINE REAMER



GOST 7722

TAPER SHANK

Size	Type 1		Type 2		M.T. Shank
	Flute Length	Overall Length	Flute Length	Overall Length	
5.5	26	138	-	-	1
6					
7					
8					
9	36	162	16	140	
10					
11	44	182	18	150	
12					
13	50	204	18	160	
14					
15	52	210	18	170	
16					
17	54	214	20	180	
18					
19	58	223	20	190	
20					
21	62	232	20	200	
22					
23	64	237	20	210	
24					
25	68	241	22	220	
26					
27	70	273	25	240	
28					
30	71	277	-	-	
32					
34	73	218	-	-	
35					
36	77	317	-	-	
38					
40	78	321	-	-	
42					
44	79	325	-	-	
45					
46	81	329	-	-	
48					
50	82	333	-	-	
	83	336	-	-	
	84	340	-	-	
	86	344	-	-	

## STC076R, MACHINE REAMER

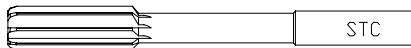

GOST1672

STRAIGHT SHANK

Size	Flute Length	Overall Length	Size	Flute Length	Overall Length
2.5	14	57	9	36	125
2.8	15	61	10	38	133
3					
3.2	16	65	11	41	142
3.5					
4	18	70	12	44	151
4.5					
5	19	75	13		
5.5					
6	21	80	14	47	160
7					
8	23	86	15	50	162
	26	93	16	52	170
	31	109	17	54	175
	33	117	18	56	182
			19	58	189
			20	60	195

## STC077RT, MORSE TAPER REAMER

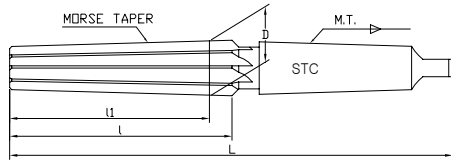

GOST10079 MORSE TAPER SHANK

Size	D	L	l	l1	M.T.
0	9.045	137	61	48	1
1	12.065	142	66	50	
2	17.78	173	79	61	2
3	23.825	212	96	76	
4	31.267	240	119	97	3
5	44.399	295	150	124	
6	63.348	389	208	176	5

## STC227R1, 1:30 TAPER PIN REAMER

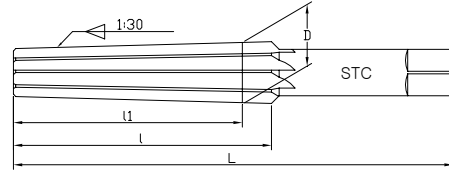

GOST11177 STRAIGHT SHANK

D	L	l	l1	D	L	l	l1
8				27	190	129	105
13	120	80	62	32	200	138	114
16	130	90	72	40	225	158	126
19	150	102	84	50	250	168	138
22	170	117	93				

## STC077RS, MORSE TAPER REAMER

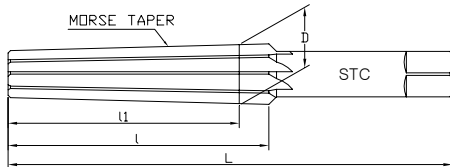

GOST 11182 STRAIGHT SHANK

Size	D	L	l	l1
0	9.045	93	61	48
1	12.065	102	66	50
2	17.78	121	79	61
3	23.825	146	96	76
4	31.267	179	119	97
5	44.399	222	150	124
6	63.348	300	208	176

## STC227R2, 1:50 TAPER PIN REAMER

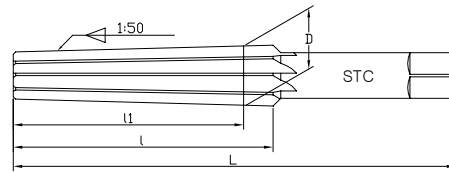

GOST11177 STRAIGHT SHANK

D	L	l	l1	D	L	l	l1
3	80	58	45	10	215	175	160
4	93	68	55	12	255	210	180
5	100	73	60	16	280	230	200
6	135	105	90	20	310	250	220
8	180	145	130	25	370	300	240

## STC227R3, 1:30 TAPER PIN REAMER

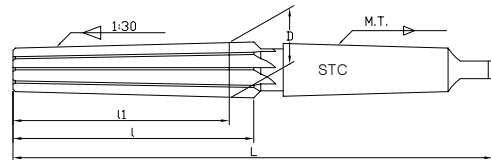

GOST 10082 MORSE TAPER SHANK

D	L	l	l1	D	L	l	l1
13	160	80	62	27	245	129	105
16	185	90	72	32	280	138	114
19	220	102	84	40	300	156	126
22	235	117	93				

## STC225R, ADJUSTABLE HAND REAMER

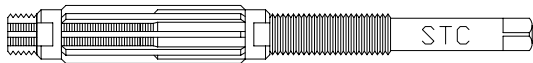

GOST

Size	Flute Length	Overall Length
10,0 -10,75		
10,75 -12,0		
12,0 -13,5	150	52
13,5 -15,25	150	56
15,25 -17,25	160	56
17,25 -19,0	170	54,5
19,0 -21,0	180	54,5
21,0 -23,0	190	72
23,0 -26,0	205	72
26,0 -29,5	240	78
29,5 -33,5	260	97
33,5 -35,0	305	97
35,0 -40,0	305	94
40,0 -43,0	305	89,4
43,0 -45,0	305	86,3
45,0 -47,0	305	84,3
47,0 -50,0	320	84,3

## STC227R4, 1:50 TAPER PIN REAMER

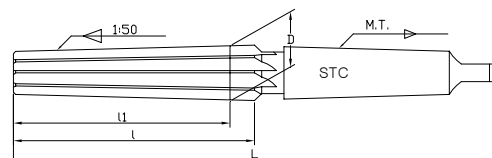

GOST 10082 MORSE TAPER SHANK

D	L	l	l1	D	L	l	l1
5	155	73	60	12	315	210	180
6	187	105	90	16	335	230	200
8	227	145	130	10	377	250	220
10	257	175	160	25	427	300	240

TAPER CHAMFER: 6 THREADS

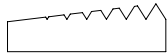

PLUG CHAMFER: 4 THREADS

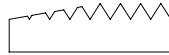

BOTTOMING CHAMFER: 2 THREADS



## STC084, HSS HAND TAPS, DIN352, 3PCS/SET

Straight Flute, Tolerance 6H. Right Hand Cutting. ISO fine Thread to DIN13. In set of three for each size.

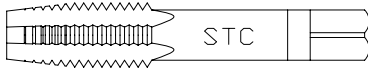

TAPER

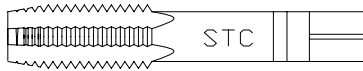

PLUG

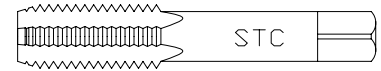

BOTTOMING

Size	Pitch	Total Length	Thread Length
M1	0.25	32	5.5
M1.1	0.25	32	5.5
M1.2	0.25	32	5.5
M1.4	0.3	32	7
M1.6	0.35	32	8
M1.7	0.35	32	8
M1.8	0.35	32	8
M2	0.4	36	8
M2.2	0.45	36	9
M2.3	0.4	36	9
M2.5	0.45	40	9
M2.6	0.45	40	9
M3	0.5	40	10
M3.5	0.6	45	12
M4	0.7	45	12

Size	Pitch	Total Length	Thread Length
M4.5	0.75	50	14
M5	0.8	50	14
M5.5	0.9	50	16
M6	1	50	16
M7	1	50	18
M8	1.25	56	22
M9	1.25	63	22
M10	1.5	70	24
M11	1.5	70	24
M12	1.75	75	29
M14	2	80	30
M16	2	80	32
M18	2.5	95	40
M20	2.5	95	40
M22	2.5	100	40

Size	Pitch	Total Length	Thread Length
M24	3	110	50
M27	3	110	50
M30	3.5	125	56
M33	3.5	125	56
M36	4	150	63
M39	4	150	63
M42	4.5	150	63
M45	4.5	160	70
M48	5	180	75
M52	5	180	75
M56	5.5	200	85
M60	5.5	200	85
M64	6	220	90
M68	6	220	90
M72	6	220	90

## STC230, HSS HAND TAPS, DIN2181, 2PCS/SET

Straight Flute. Tolerance 6H. Right Hand Cutting. ISO Fine Thread to DIN13. In set of 2pcs for each size.

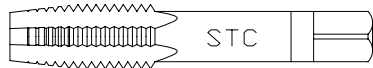

Size	Pitch	Total Length	Thread Length
M2x0.25	0.25	36	8
M2.2x0.25	0.25	36	9
M2.3x0.25	0.25	36	9
M2.5x0.35	0.35	40	9
M2.6x0.35	0.35	40	9
M3x0.35	0.35	40	9
M3.5x0.35	0.35	45	10
M4x0.35	0.35	45	10
M4x0.5	0.5	45	12
M5x0.5	0.5	50	14
M6x0.6	0.5	50	14
M6x0.75	0.75	50	14
M7x0.75	0.75	50	19
M8x0.5	0.5	50	19
M8x0.75	0.75	50	22
M8x1	1	63	22
M9x1	1	63	20
M10x0.75	0.75	63	20
M10x1	1	70	24
M10x1.25	1.25	63	22
M11x1	1	70	22

Size	Pitch	Total Length	Thread Length
M12x1	1	70	22
M12x1.25	1.25	70	22
M12x1.5	1.5	70	22
M14x1	1	70	22
M14x1.25	1.25	70	22
M14x1.5	1.5	70	22
M15x1	1	70	22
M15x1.5	1.5	70	22
M16x1	1	70	22
M16x1.5	1.5	70	22
M18x1	1	80	22
M18x1.5	1.5	80	22
M18x2	2	80	22
M20x1	1	80	22
M20x1.5	1.5	80	22
M20x1	2	80	22
M22x1	1	80	22
M22x1.5	1.5	80	22
M22x1	2	80	22
M24x1	1	90	22
M24x1.5	1.5	90	22

Size	Pitch	Total Length	Thread Length
M24x2	2	90	22
M26x1.5	1.5	90	22
M27x1.5	1.5	90	22
M27x2	2	90	22
M28x1.5	1.5	90	22
M30x1	1	90	22
M30x1.5	1.5	90	22
M30x2	2	90	22
M32x1.5	1.5	90	22
M33x1.5	1.5	100	25
M34x1.5	1.5	100	25
M35x1.5	1.5	100	25
M36x1.5	1.5	100	25
M36x3	3	125	40
M38x1.5	1.5	100	25
M40x1.5	1.5	110	25
M42x1.5	1.5	110	24
M45x1.5	1.5	110	25
M48x1.5	1.5	140	40
M52x1.5	1.5	140	40

## STC085-A, HSS MACHINE TAPS, DIN371, STRAIGHT FLUTE

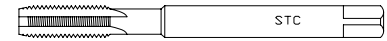

Size	Pitch	Total Length	Thread Length
M1.4	0.3	40	7
M1.6	0.35	40	8
M1.8	0.35	40	8
M2	0.4	45	8
M2.2	0.45	45	9

Size	Pitch	Total Length	Thread Length
M2.5	0.45	50	9
M3	0.5	56	11
M3.5	0.6	56	13
M4	0.7	63	13
M5	0.8	70	16

Size	Pitch	Total Length	Thread Length
M6	1	80	19
M7	1	80	19
M8	1.25	90	22
M9	1.25	90	22
M10	1.5	100	24

## STC085-B, HSS MACHINE TAPS, DIN371, SPIRAL FLUTE



Size	Pitch	Total Length	Thread Length
M1.4	0.3	40	7
M1.6	0.35	40	8
M1.8	0.35	40	8
M2	0.4	45	8
M2.2	0.45	45	9

Size	Pitch	Total Length	Thread Length
M2.5	0.45	50	9
M3	0.5	56	11
M3.5	0.6	56	13
M4	0.7	63	13
M5	0.8	70	16

Size	Pitch	Total Length	Thread Length
M6	1	80	19
M7	1	80	19
M8	1.25	90	22
M9	1.25	90	22
M10	1.5	100	24

## STC085-C, HSS MACHINE TAPS, DIN371, SPIRAL POINT



Size	Pitch	Total Length	Thread Length
M1.4	0.3	40	7
M1.6	0.35	40	8
M1.8	0.35	40	8
M2	0.4	45	8
M2.2	0.45	45	9

Size	Pitch	Total Length	Thread Length
M2.5	0.45	50	9
M3	0.5	56	11
M3.5	0.6	56	13
M4	0.7	63	13
M5	0.8	70	16

Size	Pitch	Total Length	Thread Length
M6	1	80	19
M7	1	80	19
M8	1.25	90	22
M9	1.25	90	22
M10	1.5	100	24

## HSS MACHINE TAPS, DIN376

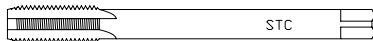

STC086-A, STRAIGHT FLUTE

Size	Pitch	Total Length	Thread Length
M3	0.5	56	11
M4	0.7	63	13
M5	0.8	70	16
M6	1	80	19
M7	1	80	19
M8	1.25	90	22
M9	1.25	90	22
M10	1.5	100	24
M11	1.5	100	24
M12	1.75	110	29
M14	2	110	30
M16	2	110	32
M18	2.5	125	34
M20	2.5	140	34
M22	2.5	140	34
M24	3	160	38
M27	3	160	38
M30	3.5	180	45
M33	3.5	180	60
M36	4	200	56
M39	4	200	60
M42	4.5	200	60
M45	4.5	220	65
M48	5	250	70
M52	5	250	70

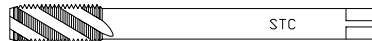

STC086-B, SPIRAL FLUTE

Size	Pitch	Total Length	Thread Length
M3	0.5	56	11
M4	0.7	63	13
M5	0.8	70	16
M6	1	80	19
M7	1	80	19
M8	1.25	90	22
M9	1.25	90	22
M10	1.5	100	24
M11	1.5	100	24
M12	1.75	110	29
M14	2	110	30
M16	2	110	32
M18	2.5	125	34
M20	2.5	140	34
M22	2.5	140	34
M24	3	160	38
M27	3	160	38
M30	3.5	180	45
M33	3.5	180	60
M36	4	200	56
M39	4	200	60
M42	4.5	200	60
M45	4.5	220	65
M48	5	250	70
M52	5	250	70

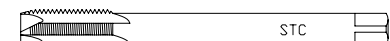

STC086-C, SPIRAL POINT

Size	Pitch	Total Length	Thread Length
M3	0.5	56	11
M4	0.7	63	13
M5	0.8	70	16
M6	1	80	19
M7	1	80	19
M8	1.25	90	22
M9	1.25	90	22
M10	1.5	100	24
M11	1.5	100	24
M12	1.75	110	29
M14	2	110	30
M16	2	110	32
M18	2.5	125	34
M20	2.5	140	34
M22	2.5	140	34
M24	3	160	38
M27	3	160	38
M30	3.5	180	45
M33	3.5	180	60
M36	4	200	56
M39	4	200	60
M42	4.5	200	60
M45	4.5	220	65
M48	5	250	70
M52	5	250	70

## STC087, HSS NUT TAPS, DIN 357



Size	Pitch	Total Length	Thread Length
M3	0.5	70	22
M4	0.7	90	25
M5	0.8	100	28
M6	1	110	32
M8	1.25	125	40

Size	Pitch	Total Length	Thread Length
M10	1.5	140	45
M12	1.75	180	50
M14	2	200	56
M16	2	200	63
M18	2.5	220	63

Size	Pitch	Total Length	Thread Length
M20	2.5	250	70
M22	2.5	280	80
M24	3	280	80
M27	3	315	90
M30	3.5	315	100

## STC088, HSS HAND TAPS, BSW, DIN 351

3pcs per set, for BSW thread as per DIN11. HSS ground thread, Carbon Steel & Alloy Steel cut thread available also.

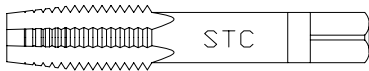

TAPER

Size	Pitch	Total Length	Thread Length
1/16"	60	32	10
3/32"	48	36	11
1/8"	40	40	12
5/32"	32	45	12
3/16"	24	50	18
7/32"	24	50	18
1/4"	20	56	22
5/16"	18	63	25

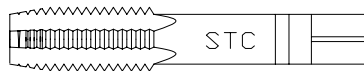

PLUG

Size	Pitch	Total Length	Thread Length
3/8"	16	70	28
7/16"	14	75	30
1/2"	12	80	32
9/16"	12	80	32
5/8"	11	90	36
3/4"	10	105	40
7/8"	9	110	45
1"	8	110	50

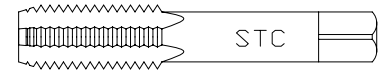

BOTTOMING

Size	Pitch	Total Length	Thread Length
1-1/8"	7	132	56
1-1/4"	7	132	56
1-3/8"	6	150	63
1-1/2"	6	150	63
1-5/8"	5	160	70
1-3/4"	5	160	70
1-7/8"	4-1/2	190	80
2"	4-1/2	190	80

## STC089-1, HSS PIPE TAPS, DIN5157

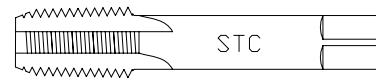

Size	Pitch	Total Length	Thread Length
G1/16"	28	56	22
G1/8"	28	63	20
G1/4"	19	70	22
G3/8"	19	70	22
G1/2"	14	80	22
G5/8"	14	80	22
G3/4"	14	90	22

Size	Pitch	Total Length	Thread Length
G7/8"	14	90	22
G1"	11	100	25
G1-1/8"	11	125	40
G1-1/4"	11	125	40
G1-1/2"	11	140	40
G1-3/4"	11	140	40
G2"	11	160	40

Size	Pitch	Total Length	Thread Length
G2-1/4"	11	160	40
G2-1/2"	11	160	40
G2-3/4"	11	160	40
G3"	11	160	40
G1-1/2"	11	180	45
G4"	11	180	45

## STC089-2, HSS PIPE TAP, DIN5156

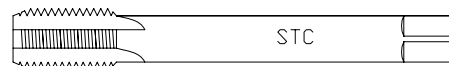

Size	Pitch	Total Length	Thread Length
G1/16"	28	90	22
G1/8"	28	90	20
G1/4"	19	100	22
G3/8"	19	100	22

Size	Pitch	Total Length	Thread Length
G1/2"	14	125	25
G5/8"	14	125	25
G3/4"	14	140	28
G7/8"	14	150	28

Size	Pitch	Total Length	Thread Length
G1"	11	160	30
G1-1/4"	11	170	30
G1-1/2"	11	190	32
G2"	11	220	40

## STC190, HAND & MACHINE TAPS, ISO529

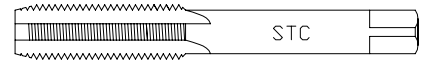

Size	Overall Length	Flute length	Shank Diameter
M1X0.2	38.5	5.5	2.5
M1X0.25	38.5	5.5	2.5
M1.1X0.2	38.5	5.5	2.5
1.1X0.25	38.5	5.5	2.5
M1.2X0.2	38.5	5.5	2.5
M1.2X0.2	38.5	5.5	2.5
M1.4X0.2	40	7	2.5
M1.4X0.3	40	7	2.5
M1.6X0.2	41	8	2.5
M1.6X0.3	41	8	2.5
M1.8X0.2	41	8	2.5
M1.8X0.3	41	8	2.5
M2X0.25	41	8	2.5
M2X0.4	41	8	2.5
M2.2X0.2	44.5	9.5	2.8
M2.2X0.4	44.5	9.5	2.8
M2.5X0.3	44.5	9.5	2.8
M2.5X0.4	44.5	9.5	2.8
M3X0.35	48	11	3.15
M3X0.5	48	11	3.15
M3.5X0.3	50	13	3.55
M3.5X0.6	50	13	3.55
M4X0.5	53	13	4
M4X0.7	53	13	4
M4.5X0.5	53	13	4.5
M4.5X0.7	53	13	4.5
M5X0.5	58	16	5
M5X0.8	58	16	5
M5.5X0.5	62	17	5.6
M6X0.75	66	19	6.3
M6X1	66	19	6.3
M7X0.75	66	19	7.1
M7X1	66	19	7.1
M8x0.75	66	19	7.1
M8X1	69	19	6.3
M8X1.25	72	22	6.3
M9X1	69	19	7.1
M9X1.25	72	22	7.1
M10X1	76	20	8
M10X1.25	76	20	8

Size	Overall Length	Flute length	Shank Diameter
M10X1.5	80	24	8
M11X1.5	85	25	8
M12X1.25	84	24	9
M12X1.5	89	29	9
M12X1.75	89	29	9
M14X1.25	90	25	11.2
M14X1.5	95	30	11.2
M14X2	95	30	11.2
M15X1.5	95	30	11.2
M16X1.5	102	32	12.5
M16X2	102	32	12.5
M17X1.5	102	32	12.5
M18X1.5	108	33	14
M18X2	108	33	14
M18X2.5	112	37	14
M20X1.5	108	33	14
M20X2	108	33	14
M20X2.5	112	37	14
M22X1.5	115	35	16
M22X2	115	35	16
M22X2.5	118	38	16
M24X1.5	120	35	18
M24X2	120	35	18
M24X3	130	45	18
M25X1.5	120	35	18
M25X2.0	120	35	18
M27X1.5	127	37	20
M27X2	127	37	20
M27X3	135	45	20
M28X1.5	127	37	20
M28X2	127	37	20
M27X3	135	45	20
M28X1.5	127	37	20
M28X2	127	37	20
M30X1.5	127	37	20
M30X2	127	37	20
M30X3	138	48	20
M30X3.5	138	48	20
M32X1.5	137	37	22.4
M32X2	137	37	22.4

Size	Overall Length	Flute length	Shank Diameter
M33X1.5	137	37	22.4
M33X2	137	37	22.4
M33X3	151	51	22.4
M33X3.5	151	51	22.4
M35X1.5	144	39	25
M36X1.5	144	39	25
M36X2	144	39	25
M36X3	162	57	25
M36X4	162	57	25
M39X0.5	149	39	28
M39X2	149	39	28
M39X3	170	60	28
M39X4	170	60	28
M40X1.5	149	39	28
M40X2	149	39	28
M40X3	170	60	28
M42X1.5	149	39	28
M42X2	149	39	28
M42X3	170	60	28
M42X4	170	60	28
M42X4.5	170	60	28
M45X1.5	165	45	31.5
M45X2	165	45	31.5
M45X3	187	67	31.5
M45X4	187	67	31.5
M45X4.5	187	67	31.5
M48X1.5	165	45	31.5
M48X2	165	45	31.5
M48X3	187	67	31.5
M48X4	187	67	31.5
M48X5	187	67	31.5
M50X1.5	165	45	31.5
M50X2	165	45	31.5
M50X3	187	67	31.5
M52X1.5	175	45	35.5
M52X2	175	45	35.5
M52X3	200	70	35.5
M52X4	200	70	35.5
M52X5	200	70	35.5

## STC190B, MACHINE TAPS, ISO529 BRITISH THREAD

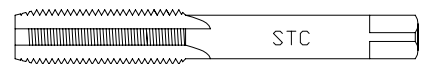

Size	Overall Length	Flute length	Shank Diameter
1/8-40	48	11	3.15
3/16-24	58	16	5
3/16-32	58	16	5
7/32-28	62	17	5.6
1/4"-20	66	19	6.3
1/4"-26	66	19	6.3
9/32-32	66	19	7.1
5/16-18	72	22	8
5/16-22	72	22	8

Size	Overall Length	Flute length	Shank Diameter
3/8"-16	80	24	10
3/8"-20	80	24	10
7/16-14	85	25	8
7/16-18	85	25	8
1/2"-12	89	29	9
1/2"-16	89	29	9
9/16-12	95	30	11.2
9/16-16	95	30	11.2
5/8"-11	102	32	12.5

Size	Overall Length	Flute length	Shank Diameter
5/8"-14	102	32	12.5
11/16-11	112	37	14
11/16-14	112	37	14
3/4"-10	112	37	14
3/4"-12	112	37	14
7/8"-9	118	38	16
7/8"-11	118	38	16
1"-8	130	45	18
1"-10	130	45	18

## STC091, HAND TAPS. ASME/ANSI B94.9

HSS Ground Thread, Carbon Steel Cut Thread, Please specify when ordering.

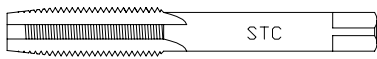

7-10 Thread Chamfer  
TAPER

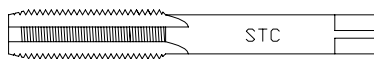

3-4 Thread Chamfer  
PLUG



1-2 Thread Chamfer  
BOTTOMING

Size	Pitch (TPI)			Thread Limited	Total Length	Thread Length
	UNC	UNF	UNS			
0	-	80		H1, H2	1-5/8"	5/16"
1	64	72		H1, H2	1-11/16"	3/8"
2	56	64		H2	1-3/4"	7/16"
3	48	56		H2	1-13/16"	1/2"
4	40	48	36	H2	1-7/8"	9/16"
5	40	44		H2	1-15/16"	5/8"
6	32	40		H2, H3	2"	11/16"
8	32	36		H2, H3	2-1/8"	3/4"
10	24	32		H2, H3	2-3/8"	7/8"
12	24	28		H2, H3	2-3/8"	15/16"
1/4"	20	28		H2, H3	2-1/2"	1"
5/16"	18	24		H2, H3	2-23/32"	1-1/8"

Size	Pitch (TPI)			Thread Limited	Total Length	Thread Length
	UNC	UNF	UNS			
3/8"	16	24		H2, H3	2-15/16"	1-1/4"
7/16"	14	20		H3	3-5/32"	1-7/16"
1/2"	13	20		H2, H3	3-3/8"	1-21/32"
9/16"	12	18		H3	3-19/32"	1-21/32"
5/8"	11	18		H3	3-13/16"	1-13/16"
3/4"	10	16		H3	4-1/2"	2"
7/8"	9	14		H3, H4	4-11/16"	2-7/32"
1"	8	12	14	H3, H4	5-1/8"	2-1/2"
1-1/8"	7	12		H3, H4	5-7/16"	2-9/16"
1-1/4"	7	12		H4	5-3/4"	2-9/16"
1-3/8"	6	12		H4	6-1/16"	3"
1-1/2"	6	12		H4	6-3/8"	3"

Note: Please write 'SIZE', 'PITCH' & 'THREAD LIMITED' when ordering. Such as "8-64 H2".

## STC092, SPIRAL POINT TAPS, ASME/ANSI B94.9

High Speed Steel, Ground Thread.

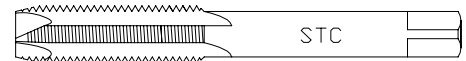

Size	Pitch (TPI)			Thread Limited	Total Length	Thread Length
	UNC	UNF	UNS			
0	-	80		H1	1-5/8"	5/16"
1	64	72		H1	1-11/16"	3/8"
2	56	64		H2	1-3/4"	7/16"
3	48	56		H2	1-13/16"	1/2"
4	40	48	36	H2	1-7/8"	9/16"
5	40	44		H2	1-15/16"	5/8"
6	32	40		H2	2"	11/16"
8	32	36		H2	2-1/8"	3/4"
10	24	32		H3	2-3/8"	7/8"
12	24	28		H3	2-3/8"	15/16"

Size	Pitch (TPI)			Thread Limited	Total Length	Thread Length
	UNC	UNF	UNS			
1/4"	20	28		H3	2-1/2"	1"
5/16"	18	24		H3	2-23/32"	1-1/8"
3/8"	16	24		H3	2-15/16"	1-1/4"
7/16"	14	20		H3	3-5/32"	1-7/16"
1/2"	13	20		H3	3-3/8"	1-21/32"
9/16"	12	18		H3	3-19/32"	1-21/32"
5/8"	11	18		H3	3-13/16"	1-13/16"
3/4"	10	16		H3	4-1/2"	2"
7/8"	9	14		H4	4-11/16"	2-7/32"
1"	8	12	14	H4	5-1/8"	2-1/2"

Note: Please write 'SIZE', 'PITCH' & 'THREAD LIMITED' when ordering. Such as "8-64 H2".

## STC093, SPIRAL FLUTE TAPS, ASME/ANSI B94.9

High Speed Steel, Ground Thread.

Regular Spiral Flute: 25° - 35°, Fast Spiral Flute: 45° - 60°.



Size	Pitch (TPI)			Thread Limited	Total Length	Thread Length
	UNC	UNF	UNS			
3	48	56		H2	1-13/16"	1/2"
4	40	48		H2	1-7/8"	9/16"
5	40	44		H2	1-15/16"	5/8"
6	32	40		H3, H2	2"	11/16"
8	32	36		H3, H2	2-1/8"	3/4"
10	24	32		H3	2-3/8"	7/8"
12	24	28		H3	2-3/8"	15/16"
1/4"	20	28		H3	2-1/2"	1"
5/16"	18	24		H3	2-23/32"	1-1/8"
3/8"	16	24		H3	2-15/16"	1-1/4"

Size	Pitch (TPI)			Thread Limited	Total Length	Thread Length
	UNC	UNF	UNS			
7/16"	14	20		H3	3-5/32"	1-7/16"
1/2"	13	20		H3	3-3/8"	1-21/32"
5/8"	11	18		H3	3-13/16"	1-13/16"
3/4"	10	16		H3	4-1/2"	2"
7/8"	9	14		H4	4-11/16"	2-7/32"
1"	8	12	14	H4	5-1/8"	2-1/2"
1-1/8"	7	12		H4	5-7/16"	2-9/16"
1-1/4"	7	12		H4	5-3/4"	2-9/16"
1-3/8"	6	12		H4	6-1/16"	3"
1-1/2"	6	12		H4	6-3/8"	3"

Note: Please write 'SIZE', 'PITCH' & 'THREAD LIMITED' when ordering. Such as "8-64 H2".

## STC095-A, PULLEY TAPS, ASME/ANSI B94.9

HSS Ground Thread  
Plug Chamfer

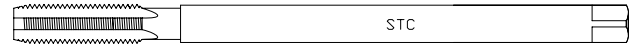

Size	Pitch (TPI)			Thread Limited	Total Length	Thread Length
	UNC	UNF	UNS			
6	32	40		H2, H3	6"	11/16"
8	32	36		H3	6"	3/4"
10	24	32		H3	6"	7/8"
1/4"	20	28		H3	6"	1"
5/16"	18	24		H3	6"	1-1/8"

Size	Pitch (TPI)			Thread Limited	Total Length	Thread Length
	UNC	UNF	UNS			
3/8"	16	24		H3	6"	1-1/4"
7/16"	14	20		H3	6"	1-7/16"
1/2"	13	20		H3	6"	1-21/32"
5/8"	11	18		H3	6"	1-13/16"
3/4"	10	16		H3	6"	2"

## STC095-B, NUT TAPS, ASME/ANSI B94.9

HSS Ground Thread  
Plug Chamfer

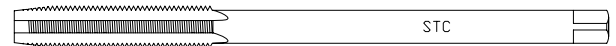

Size	Pitch (TPI)			Thread Limited	Total Length	Thread Length
	UNC	UNF	UNS			
1/4"	20			H3	5"	1-5/8"
1/4"		28		H3	5"	1-1/4"
5/16"	18			H3	5-1/2"	1-13/16"
5/16"				H3	5-1/2"	1-3/8"
3/8"	16			H3	6"	2"
3/8"		24		H3	6"	1-1/2"
7/16"	14			H3	6-1/2"	2-3/8"
7/16"		20		H3	6-1/2"	1-3/4"
1/2"	13			H3	7"	2-1/2"
1/2"		20		H3	7"	1-7/8"

Size	Pitch (TPI)			Thread Limited	Total Length	Thread Length
	UNC	UNF	UNS			
9/16"	12			H3	7-1/2"	2-3/4"
9/16"		18		H3	7-1/2"	2"
5/8"	11			H3	8"	3"
5/8"		18		H3	8"	2-1/4"
3/4"	10			H3	9"	3-1/4"
3/4"		6		H3	9"	2-1/2"
7/8"	9			H4	10"	3-5/8"
7/8"		14		H4	10"	2-3/4"
1"	8			H4	11"	4"
1"		12		H4	11"	3-1/2"
1"			14	H4	11"	3"

## STC096-D, HSS LEFT HAND TAPS, ASME/ANSI B94.9

HSS - Ground Thread, Carbon Steel - Cut Thread.



Size	Pitch (TPI)			Thread Limited	Total Length	Thread Length
	UNC	UNF	UNS			
6	32	40		H3	2"	11/16"
8	32	36		H3	2-1/8"	3/4"
10	24	32		H3	2-3/8"	7/8"
12	24	28		H3	2-3/8"	15/16"
1/4"	20	28		H3	2-1/2"	1"
5/16"	18	24		H3	2-23/32"	1-1/8"
3/8"	16	24		H3	2-15/16"	1-1/4"
7/16"	14	20		H3	3-5/32"	1-7/16"
1/2"	13	20		H3	3-3/8"	1-21/32"

Size	Pitch (TPI)			Thread Limited	Total Length	Thread Length
	UNC	UNF	UNS			
9/16"	12	18		H3	3-19/32"	1-21/32"
5/8"	11	18		H3	3-13/16"	1-13/16"
3/4"	10	16		H3	4-1/2"	2"
7/8"	9	14		H4	4-11/16"	2-7/32"
1"	8	12	14	H4	5-1/8"	2-1/2"
1-1/8"	7	12		H4	5-7/16"	2-9/16"
1-1/4"	7	12		H4	5-3/4"	2-9/16"
1-3/8"	6	12		H4	6-1/16"	3"
1-1/2"	6	12		H4	6-3/8"	3"

## STC232, LONG REACH EXTENSION TAPS, PLUG CHAMFER

HSS - Ground Thread  
Plug Chamfer  
STRAIGHT FLUTE,



Size	Pitch (TPI)			Thread Limited	Total Length	Shank Diameter
	UNC	UNF	UNS			
1/4"	20	28	-	H3	6"	0.185"
5/16"	18	24	-	H3	6"	0.240"
3/8"	16	24	-	H3	6"	0.275"

SPIRAL POINT

Size	Pitch (TPI)			Thread Limited	Total Length	Shank Diameter
	UNC	UNF	UNS			
1/4"	20	28	-	H3	6"	0.185"
5/16"	18	24	-	H3	6"	0.240"
3/8"	16	24	-	H3	6"	0.275"

## STC093A, THREAD FORMING TAPS, ASME/ANSI B94.9

HSS - Ground Thread

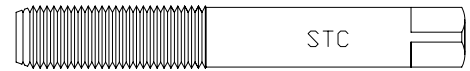

Size	Pitch (TPI)	Total Length	Thread Length
3	48	1-13/16"	1/2"
3	56	1-13/16"	1/2"
4	40	1-7/8"	9/16"
4	48	1-7/8"	9/16"
5	40	1-15/16"	5/8"
5	44	1-15/16"	5/8"
6	32	2"	11/16"
6	40	2"	11/16"
8	32	2-1/8"	3/4"
8	36	2-1/8"	3/4"

Size	Pitch (TPI)	Total Length	Thread Length
10	24	2-3/8"	7/8"
10	32	2-3/8"	7/8"
12	24	2-3/8"	15/16"
12	20	2-3/8"	15/16"
1/4"	20	2-1/2"	1"
1/4"	28	2-1/2"	1"
5/16"	18	2-23/32"	1-1/8"
5/16"	24	2-23/32"	1-1/8"
3/8"	16	2-15/16"	1-1/4"
3/8"	24	2-15/16"	1-1/4"

Size	Pitch (TPI)	Total Length	Thread Length
7/16"	14	3-5/32"	1-7/16"
7/16"	20	3-5/32"	1-7/16"
1/2"	13	3-3/8"	1-21/32"
1/2"	20	3-3/8"	1-21/32"
9/16"	12	3-19/32"	1-21/32"
9/16"	18	3-19/32"	1-21/32"
5/8"	11	3-13/16"	1-13/16"
5/8"	18	3-13/16"	1-13/16"
3/4"	10	4-1/4"	2"

## STC233, SINGLE PASS ACME TAPS, ASME/ANSI B94.9

HSS - Ground Thread



Size	Pitch (TPI)	Total Length	Thread Length
3/8"	12	5"	2-9/16"
1/2"	10	5"	2-9/16"
5/8"	8	6-1/4"	3-3/16"
3/4"	6	7-15/16"	4-5/16"

Size	Pitch (TPI)	Total Length	Thread Length
3/4"	8	7-15/16"	4-5/16"
7/8"	6	8-5/8"	4-3/8"
1"	5	10-1/8"	5-1/4"
1-1/8"	5	10-3/4"	5-1/4"

Size	Pitch (TPI)	Total Length	Thread Length
1-1/4"	5	11-1/8"	5-1/4"
1-3/8"	4	12-1/4"	5-7/8"
1-1/2"	4	12-5/8"	5-7/8"
1-3/4"	4	13-3/8"	5-7/8"

## STC003, COMBINED DRILL & TAPS

HSS - Ground Thread, 2-Flute



### INCH SIZES

Size	Drill Diameter	Total Length	Thread Length
4-40	0.0890"	1-7/8"	9/16"
4-48	0.0930"	1-7/8"	9/16"
5-40	0.1015"	1-15/16"	5/8"
6-32	0.1095"	2"	11/16"
6-40	0.1150"	2"	11/16"
8-32	0.1360"	2-1/8"	3/4"
10-24	0.1520"	2-3/8"	7/8"
10-32	0.1610"	2-3/8"	7/8"
12-24	0.1770"	2-3/8"	7/8"
12-28	0.1835"	2-3/8"	7/8"

### INCH SIZES

Size	Drill Diameter	Total Length	Thread Length
1/4"-20	0.2010"	2-1/2"	1"
1/4"-28	0.2175"	2-1/2"	1"
5/16"-18	0.2570"	2-23/32"	1-1/8"
5/16"-24	0.2720"	2-23/32"	1-1/8"
3/8"-16	0.3125"	2-15/16"	1-1/4"
3/8"-24	0.3345"	2-15/16"	1-1/4"
7/16"-14	0.2680"	3-5/32"	1-7/16"
7-16"-20	0.3890"	3-5/32"	1-7/16"
1/2"-13	0.4250"	3-3/8"	1-21/32"
1/2"-20	0.4510"	3-3/8"	1-21/32"

### METRIC SIZES

Size	Drill Diameter	Total Length	Thread Length
M3x0.5	0.1015"	1-15/16"	13/32"
M3.5x0.6	0.1180"	2"	7/16"
M4x0.7	0.1340"	2-1/8"	1/2"
M4.5x0.75	0.1520"	2-3/8"	5/8"
M5x0.8	0.1700"	2-3/8"	5/8"
M6x1	0.2030"	2-1/2"	25/32"
M7x1	0.2420"	2-27/32"	15/16"
M8x1.25	0.2735"	2-27/32"	15/16"
M10x1.5	0.3440"	3-3/8"	1-1/16"
M12x1.75	0.4140"	4-1/16"	1-3/8"

## STC097A, TAPER PIPE TAPS (NPT / NPTF ), ASME/ANSI B94.9

Size	Pitch (TPI)	Total Length	Thread Length
1/16"	27	2-1/8"	11/16"
1/8"	27	2-1/8"	3/4"
1/4"	18	2-7/16"	1-1/16"
3/8"	18	2-9/16"	1-1/16"
1/2"	14	3-1/8"	1-3/8"
3/4"	14	3-1/4"	1-3/8"
1"	11-1/2	3-3/4"	1-3/4"

Size	Pitch (TPI)	Total Length	Thread Length
1-1/4"	11-1/2	4"	1-3/4"
1-1/2"	11-1/2	4-1/4"	1-3/4"
2"	11-1/2	4-1/2"	1-3/4"
2-1/2"	8	5-1/2"	2-9/16"
3"	8	6"	2-5/8"
3-1/2"	8	6-1/2"	2-11/16"
4"	8	6-3/4"	2-3/4"

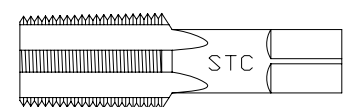

## STC097-C, HSS INTERRUPTED THREAD NPT PIPE TAPS, ASME/ANSI B94.9

Size	Pitch (TPI)	Total Length	Thread Length
1/16"	27	2-1/8"	11/16"
1/8"	27	2-1/8"	3/4"
1/4"	18	2-7/16"	1-1/16"
3/8"	18	2-7/16"	1-1/16"
1/2"	14	3-1/8"	1-3/8"

Size	Pitch (TPI)	Total Length	Thread Length
3/4"	14	3-1/4"	1-3/8"
1"	11-1/2	3-3/4"	1-3/4"
1-1/4"	11-1/2	4"	1-3/4"
1-1/2"	11-1/2	4-1/4"	1-3/4"
2"	11-1/2	4-1/2"	1-3/4"

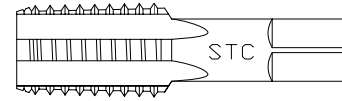

## STC097-D, STRAIGHT PIPE TAPS (NPS), ASME/ANSI B94.9

Size	Pitch (TPI)	Total Length	Thread Length
1/16"	27	2-1/8"	11/16"
1/8"	27	2-1/8"	3/4"
1/4"	18	2-7/16"	1-1/16"
3/8"	18	2-7/16"	1-1/16"
1/2"	14	3-1/8"	1-3/8"
3/4"	14	3-1/4"	1-3/8"

Size	Pitch (TPI)	Total Length	Thread Length
1"	11-1/2	3-3/4"	1-3/4"
1-1/4"	11-1/2	4"	1-3/4"
1-1/2"	11-1/2	4-1/4"	1-3/4"
2"	11-1/2	4-1/2"	1-3/4"
3"	8	6"	2-5/8"
4"	8	6-3/4"	2-3/4"

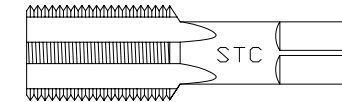

## STC096, SPECIAL THREAD TAPS, ASME/ANSI B94.9

HSS - Ground Thread, Carbon Steel - Cut Thread



Size	Pitch (TPI)	Thread Limited	Total Length
1/4"	24	H3	2-1/2"
1/4"	32	H3	2-1/2"
1/4"	40	H2, H3	2-1/2"
5/16"	20	H3	2-3/32"
5/16"	32	H2, H3	2-3/32"
5/16"	40	H3	2-3/32"
3/8"	14	H3	2-5/16"
3/8"	18	H3	2-5/16"
3/8"	20	H3	2-5/16"
3/8"	32	H3	2-5/16"
7/16"	24	H3	3-5/32"
7/16"	27	H3	3-5/32"
1/2"	12	H3	3-3/8"
1/2"	14	H3	3-3/8"
1/2"	16	H3	3-3/8"
1/2"	18	H3	3-3/8"
1/2"	24	H3	3-3/8"
1/2"	32	H3	3-3/8"
9/16"	10	H3	3-19/32"
9/16"	16	H3	3-19/32"
9/16"	20	H3	3-19/32"
9/16"	24	H3	3-19/32"
5/8"	12	H3	3-13/16"
5/8"	16	H3	3-13/16"
5/8"	20	H3	3-13/16"
5/8"	24	H3	3-13/16"
5/8"	32	H3	3-13/16"
5/8"	36	H3	3-13/16"
11/16"	11	H3	4-1/32"
11/16"	16	H3	4-1/32"
11/16"	18	H3	4-1/32"
11/16"	20	H3	4-1/32"
11/16"	24	H3	4-1/32"
11/16"	32	H3	4-1/32"
3/4"	12	H3	4-1/4"

Size	Pitch (TPI)	Thread Limited	Total Length
3/4"	18	H3	4-1/4"
3/4"	20	H3	4-1/4"
3/4"	24	H3	4-1/4"
3/4"	27	H3	4-1/4"
3/4"	32	H3	4-1/4"
13/16"	16	H3	4-15/32"
13/16"	20	H3	4-15/32"
13/16"	32	H3	4-15/32"
7/8"	12	H4	4-11/16"
7/8"	16	H3, H4	4-11/16"
7/8"	18	H3, H4	4-11/16"
7/8"	20	H3	4-11/16"
15/16"	12	H4	4-29/32"
15/16"	16	H3	4-29/32"
15/16"	20	H3	4-29/32"
15/16"	27	H3	4-29/32"
15/16"	32	H3	4-29/32"
1"	10	H4	5-1/8"
1"	16	H3	5-1/8"
1"	18	H4	5-1/8"
1"	20	H4	5-1/8"
1"	32	H3	5-1/8"
1-1/16"	8	H4	5-1/8"
1-1/16"	10	H5	5-1/8"
1-1/16"	12	H4	5-1/8"
1-1/16"	14	H3	4"
1-1/16"	16	H4	4"
1-1/16"	18	H4	4"
1-1/16"	20	H3	4"
1-1/16"	24	H3	4"
1-1/16"	32	H3	4"
1-1/8"	8	H4	5-7/16"
1-1/8"	10	H4	5-7/16"
1-1/8"	16	H4	4"
1-1/8"	18	H3	4"

Size	Pitch (TPI)	Thread Limited	Total Length
1-1/8"	32	H3	4"
1-3/16"	8	H4	5-7/16"
1-3/16"	10	H4	5-7/16"
1-3/16"	12	H4	5-7/16"
1-3/16"	14	H4	4"
1-3/16"	16	H4	4"
1-3/16"	18	H4	4"
1-3/16"	20	H3	4"
1-3/16"	24	H3	4"
1-3/16"	32	H3	4"
1-1/4"	8	H4	5-3/4"
1-1/4"	10	H4	5-3/4"
1-1/4"	14	H4	4"
1-1/4"	16	H4	4"
1-1/4"	18	H4	4"
1-1/4"	20	H3	4"
1-1/4"	24	H3	4"
1-5/16"	8	H4	5-3/4"
1-5/16"	12	H4	5-3/4"
1-5/16"	16	H4	4"
1-5/16"	18	H4	4"
1-3/8"	8	H4	6-1/16"
1-3/8"	10	H4	6-1/16"
1-3/8"	14	H4	4"
1-3/8"	16	H4	4"
1-3/8"	18	H4	4"
1-3/8"	20	H4	4"
1-7/16"	12	H4	6-1/16"
1-7/16"	16	H4	4"
1-7/16"	18	H4	4"
1-1/2"	8	H4	6-3/8"
1-1/2"	10	H4	6-3/8"
1-1/2"	16	H4	4"
1-1/2"	18	H4	4"
1-1/2"	20	H4	4"

## STC190R-2, HAND & MACHINE TAPS

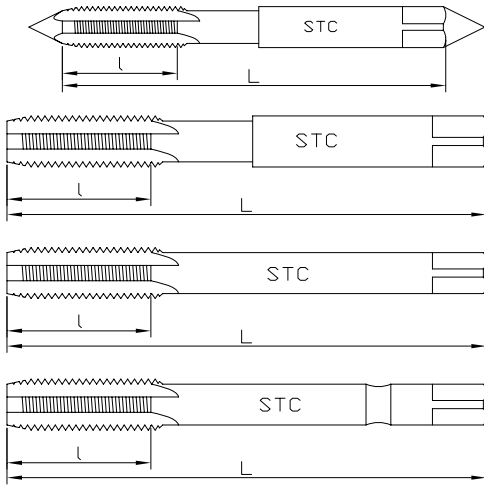

GOST3266-81, HSS GROUND THREAD

Size	Pitch	L / l, mm	Size	Pitch	L / l, mm
3	0.5	48 / 11	15	1.5	95 / 30
	0.35			84 / 24	
3.5	0.6	50 / 13	16	2.0	102 / 32
	0.35			1.5	90 / 29
4	0.7	53 / 13	17	1.0	90 / 20
	0.5			0.5	80 / 19
4.5	0.75	53 / 13	18	1.5	102 / 32
	0.5			1.0	90 / 29
5	0.8	58 / 16	22	2.5	112 / 37
	0.5			2.0	102 / 29
5.5	0.5	62 / 17	24	1.5	112 / 37
	1.0			1.0	102 / 29
6	0.75	66 / 19	25	0.75	102 / 20
	0.5			0.5	90 / 20
	1.0			2.5	118 / 38
7	1.0	66 / 19	26	2.0	118 / 38
	0.75			1.5	112 / 29
8	1.25	72 / 22	27	1.0	112 / 29
	1.0			0.75	112 / 20
	0.75			3.0	130 / 45
	0.5			2.0	113 / 33
9	1.25	72 / 22	28	1.5	113 / 25
	1.0			1.0	113 / 33
	1.5			0.75	120 / 35
10	1.25	80 / 24	30	2.0	120 / 35
	1.0			1.0	113 / 33
	0.75			3.0	135 / 45
	0.5			2.0	127 / 37
11	1.5	85 / 25	27	1.5	127 / 37
	1.0			1.0	120 / 33
	1.75			2.0	127 / 37
	1.5			1.5	120 / 33
	1.25			1.0	120 / 33
12	1.25	89 / 29	28	1.0	120 / 33
	1.0			2.0	127 / 37
	0.75			1.5	127 / 37
	0.5			1.0	120 / 33
	2.0			3.5	138 / 48
14	1.5	95 / 30	30	3.0	138 / 48
	1.0			2.0	127 / 37
	0.75			1.5	127 / 37
	0.5			1.0	120 / 33

## STC190R-2, HAND & MACHINE TAPS

Size	Pitch	L / l, mm	Size	Pitch	L / l, mm	
33	3,5	151 / 51	45	4,5	187 / 67	
	3,0			4,0		
	2,0	3,0				
	1,5	2,0		165 / 45		
	1,0	1,5		151 / 37		
36	4,0	162 / 57	48	5,0	187 / 67	
	3,0	144 / 39		4,0		3,0
	2,0	130 / 32		2,0	165 / 45	
	1,0	170 / 60		1,5	151 / 37	
39	4,0	170 / 60	52	1,0	200 / 70	
	3,0	149 / 39		5,0	175 / 45	
	2,0	144 / 37		4,0		3,0
42	1,5	149 / 39		52	2,0	175 / 45
	4,5				1,5	165 / 37
	4,0	1,0	144 / 37			
	3,0	1,0	144 / 37			
	2,0	1,0	144 / 37			

## STC190R-3, HAND TAPS, 2pcs/set

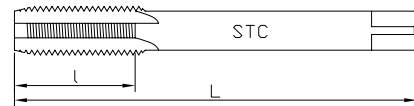

ALLOY STEEL, CUT THREAD, GOST

Size	Pitch	L / l, mm	Size	Pitch	L / l, mm
6	1,0	50 / 18	18	2,5	90 / 40
	0,75			1,5	85 / 35
	0,5			1,0	80 / 30
8	1,25	60 / 20	20	0,75	75 / 25
	1,0			2,5	90 / 40
	0,75			2,0	85 / 35
	0,5			1,5	80 / 30
10	1,5	60 / 20	22	0,75	75 / 25
	1,25			2,5	95 / 40
	1,0			2,0	90 / 35
	0,75			1,5	85 / 30
12	1,75	70 / 28	24	1,0	85 / 30
	1,5			0,75	80 / 25
	1,25			3,0	100 / 45
	1,0			2,0	95 / 40
	0,75			1,5	90 / 35
14	2,0	75 / 35	27	1,0	85 / 30
	1,5			3,0	105 / 45
	1,25			2,0	100 / 40
	1,0			1,5	95 / 35
	0,75			1,0	90 / 30
16	2,0	80 / 35	27	0,75	90 / 30
	1,5			2,0	100 / 40
	1,0			1,5	95 / 35
	0,75			1,0	90 / 30
	0,5			0,75	90 / 30

## STC190R-4, PIPE TAPS, GOST6227

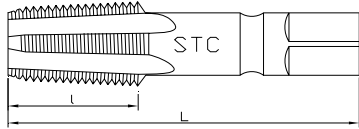

Material; HSS, Ground Thread

Size	Pitch	L / l, mm	Size	Pitch	L / l, mm
K1/16	27	50 / 16	K3/4	14	95 / 32
K1/8	27	55 / 18	K1	11.1/2	110 / 40
K1/4	18	65 / 24	K1-1/4	11.1/2	120 / 42
K3/8	18	75 / 26	K1-1/2	11.1/2	140 / 42
K1/2	14	85 / 30	K2	11.1/2	140 / 45

## STC190-5, STRAIGHT PIPE TAPS

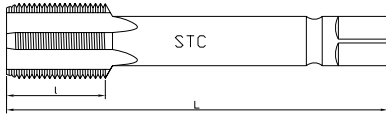

ALLOY STEEL, CUT THREAD

Size	Pitch	L / l, mm	Size	Pitch	L / l, mm
G1/8	28	55 / 18	G1/2	14	125 / 32
G1/4	19	65 / 25	G3/4	14	135 / 32
G3/8	19	70 / 25	G1/2	11	140 / 40
G1/2	14	80 / 32	G1/1/4	11	160 / 40
G3/4	14	85 / 32	G1.1/2	11	160 / 40
G1	11	95 / 40	G1.3/4	11	195 / 40
			G2	11	195 / 40

## STC190R-5, ROUND DIES, GOST9740

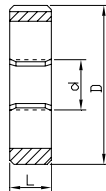
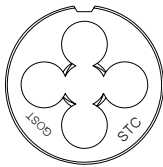

Size	Pitch	Outside	Size	Pitch	Outside		
2	0,4	16	8	1,25	25		
	0,25						
2.2	0,45	16		9		0,75	25
	0,25						
2.5	0,45	16	10		1,25	30	
	0,35						
3	0,5	20		11	1,0		30
	0,35						
3.5	0,35	20	12		1,5	38	
	0,7						
4	0,5	20		11	1,25		30
	0,5						
4.5	0,5	20	12		1,0	38	
	0,8						
5	0,5	20		11	0,75		30
	1,0						
6	0,75	20	12		0,5	38	
	0,5						
	1,25						
	1,0						
7	0,75	25	12	1,75	38		
	0,5						
	0,5						

## STC190R-5, ROUND DIES, GOST9740

Size	Pitch	Outside	Size	Pitch	Outside
12	1,0	38	20	1,0	45
	0,75				
	0,5				
14	2,0	38	22	2,5	55
	1,5				
	1,25				
	1,0		55	24	2,0
	0,75				
	0,5				
15	2,0	38	25	3,0	65
	1,5				
	1,25				
	1,0		65	27	2,0
	0,75				
16	2,0	45	27	1,5	65
	1,5				
	1,0				
17	2,0	45	28	3,5	65
	1,5				
	1,0				
18	2,5	45		28	
	2,0				
	1,5				
20	1,0	45	30	1,0	65
	2,5				
	2,0				
1,5					

## STC190R-6, PIPE DIE, GOST9740

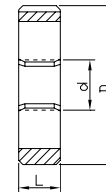
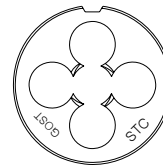

Size	Pitch	Outside	Size	Pitch	Outside
G 1/8	28	30	G 5/8	14	55
G 1/4	19	38	G 3/4	14	55
G 3/8	19	45	G 7/8	14	65
G 1/2	14	45	G 1	11	65

## STC190R-7, PIPE DIE, GOST6228

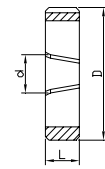
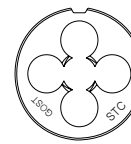

Size	Pitch	Outside	Size	Pitch	Outside
R 1/8	28	30	K 1/8	27	30
R 1/4	19	38	K 1/4	18	38
R 3/8	19	45	K 3/8	18	45
R 1/2	14	55	K 1/2	14	45
R 3/4	14	55	K 3/4	14	55
R 1	11	65	K 1	11	65

## STC098A1, ROUND DIE, DIN223

Right Hand, Tolerance 6g. 6h pls specify when ordering.

Material: GCr15. HSS or Carbon Steel pls specify when ordering.

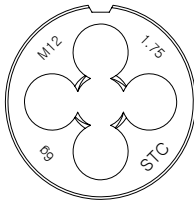

Size	Pitch	Outside
M2	0.4	16x5
M2.2	0.45	16x5
M2.3	0.4	16x5
M2.5	0.45	16x5
M2.6	0.45	16x5
M3	0.5	20x5
M3.5	0.6	20x5
M4	0.7	20x5
M4.5	0.75	20x7
M5	0.8	20x7
M6	1	20x7
M7	1	25x9
M8	1.25	25x9
M9	1.25	25x9
M10	1.5	30x11
M11	1.5	30x11

Size	Pitch	Outside
M12	1.75	38x11
M14	2	38x11
M16	2	45x18
M18	2.5	45x18
M20	2.5	45x18
M22	2.5	55x22
M24	3	55x22
M27	3	65x25
M30	3.5	65x25
M33	3.5	65x25
M36	4	65x25
M39	4	75x30
M42	4.5	75x30
M45	4.5	90x36
M48	5	90x36
M52	5	90x36

## STC098A2, ROUND DIE, FINE THREAD

Right Hand, Tolerance 6g. 6h pls specify when ordering.

Material: GCr15. HSS or Carbon Steel pls specify when ordering.

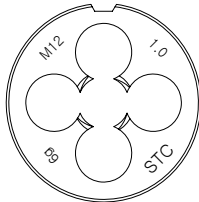

DIN223B

Size	Pitch	Outside
M2x0.25	0.25	16
M2x0.35	0.35	16
M3x0.35	0.35	20
M4x0.5	0.5	20
M4.5x0.5	0.5	20
M5x0.5	0.5	20
M5.5x0.5	0.5	20
M6x0.75	0.75	20
M7x0.75	0.75	25
M8x0.75	0.75	25
M8x1	1	25
M9x0.75	0.75	25
M9x1	1	25
M10x0.75	0.75	30
M10x1	1	30
M10x1.25	1.25	30
M11x0.75	0.75	30
M11x1	1	30
M12x1	1	38
M12x1.25	1.25	38
M12x1.5	1.5	38
M14x1	1	38

Size	Pitch	Outside
M14x1.25	1.25	38
M14x1.5	1.5	38
M15x1.5	1.5	38
M16x1	1	45
M16x1.5	1.5	45
M17x1.5	1.5	45
M18x1	1	45
M18x1.5	1.5	45
M18x2	2	45
M20x1	1	45
M20x1.5	1.5	45
M20x2	2	45
M22x1	1	55
M22x1.5	1.5	55
M22x2	2	55
M24x1	1	55
M24x1.5	1.5	55
M24x2	2	55
M25x1.5	1.5	55
M25x2	2	55
M27x1	1	65
M27x1.5	1.5	65

## STC098A2, ROUND DIE, FINE THREAD

DIN223B

Size	Pitch	Outside
M27x2	2	65
M28x1	1	65
M28x1.5	1.5	65
M28x2	2	65
M30x1	1	65
M30x1.5	1.5	65
M30x2	2	65
M30x3	3	65
M32x1.5	1.5	65
M32x2	2	65
M33x1	1	65
M33x1.5	1.5	65
M33x2	2	65
M33x3	3	65
M35x1.5	1.5	65
M36x1.5	1.5	65
M36x2	2	65
M36x3	2	65
M39x1.5	1.5	75
M39x2	2	75
M39x3	2	75

Size	Pitch	Outside
M40x1.5	1.5	75
M40x2	2	75
M40x3	3	75
M42x1.5	1.5	75
M42x2	2	75
M42x3	3	75
M42x4	4	75
M45x1.5	1.5	90
M45x2	2	90
M45x3	3	90
M45x4	4	90
M48x1.5	1.5	90
M48x2	2	90
M48x3	3	90
M48x4	4	90
M50x1.5	1.5	90
M50x2	2	90
M50x3	3	90
M52x1.5	1.5	90
M52x2	2	90
M52x3	3	90
M52x4	4	90

## STC235, ROUND DIE, 25.4MM O.D.

Material: GCr15. HSS or Carbon Steel pls specify when ordering.

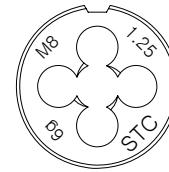

Size	Pitch	Outside
M3	0.5	25x9
M4	0.7	25x9
M5	0.8	25x9
M6	1	25x9

Size	Pitch	Outside
M8	1.25	25x9
M10	1.5	25x9
M12	1.75	25x9

## STC098B, BSW ROUND DIES, DIN223

Material: GCr15. HSS or Carbon Steel pls specify when ordering.

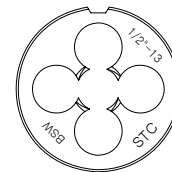

Size	Pitch	Outside
1/16"	60	16
3/32"	48	16
1/8"	40	20
5/32"	32	20
3/16"	24	20
7/32"	24	20
1/4"	20	25
5/16"	18	25
3/8"	16	30
7/16"	14	30
1/2"	12	38

Size	Pitch	Outside
9/16"	12	38
5/8"	11	45
11/16"	11	45
3/4"	10	45
7/8"	9	55
1"	8	55
1-1/8"	7	65
1-1/4"	7	65
1-1/2"	6	75
1-3/4"	5	90
2"	4-1/2	90

## STC098D, STRAIGHT PIPE DIE, DIN5158

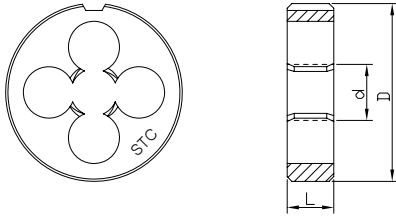

Size	Pitch	Outside
G1/16	28	25x9
G1/8	28	30x11
G1/4	19	38x10
G3/8	19	45x14
G1/2	14	45x14
G5/8	14	55x16
G3/4	14	55x16
G7/8	14	65x18

Size	Pitch	Outside
G1	11	65x18
G1-1/8	11	75x20
G-1/4	11	75x20
G-1/2	11	90x22
G1-3/4	11	105x22
G2	11	105x22
G2-1/2	11	120x36

## STC098E, TAPER PIPE DIE, DIN5159

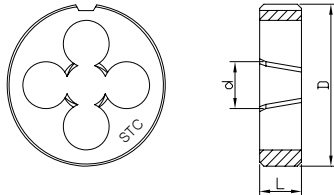

Size	Pitch	Outside
R1/16	28	33x11
R1/8	28	30x11
R1/4	19	38x14
R3/8	19	45x18
R1/2	14	55x22

Size	Pitch	Outside
R3/4	14	55x22
R1	11	65x25
R1-1/4	11	75x30
R1-1/2	11	90x36
R2	11	105x36

## STC100D, HEXAGON DIE, METRIC

Material: Alloy Steel. HSS pls specify when ordering.  
Right Hand. Left hand also available on request.



Size	Pitch	Outside
M3	0.5	19x5
M3.5	0.6	19x5
M4	0.7	19x5
M4.5	0.75	19x7
M5	0.8	19x7
M6	1	19x7
M7	1	22x9
M8	1.25	22x9
M9	1.25	22x9
M10	1.5	27x11
M11	1.5	27x11
M12	1.75	36x14
M14	2	36x14
M16	2	41x18

Size	Pitch	Outside
M18	2.5	41x18
M20	2.5	41x18
M22	2.5	50x22
M24	3	50x22
M27	3	60x25
M30	3.5	60x25
M33	3.5	60x25
M36	4	60x25
M39	4	70x30
M42	4.5	70x30
M45	4.5	85x36
M48	5	85x36
M52	5	85x36

## STC100E, HEXAGON DIE, FINE THREAD

Material: Alloy Steel. HSS pls specify when ordering.  
Right Hand. Left hand also available on request.

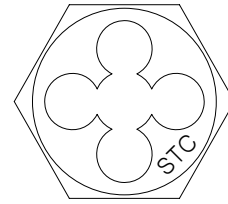

Size	Pitch	Outside
M3x0.35	0.35	19x5
M4x0.5	0.5	19x5
M4.5x0.5	0.5	19x5
M5x0.5	0.5	19x5
M5.5x0.5	0.5	19x5
M6x0.75	0.75	19x5
M7x0.75	0.75	22x9
M8x0.75	0.75	22x9
M8x1	1	22x9
M9x0.75	0.75	22x9
M9x1	1	22x9
M10x0.75	0.75	27x11
M10X1	1	27x11
M10X1.25	1.25	27x11
M11x0.75	0.75	27x11
M11x1	1	27x11
M12x1	1	36x10
M12x1.25	1.25	36x10
M12x1.5	1.5	36x10
M14X1	1	36x10
M14X1.25	1.25	36x10
M14x1.5	1.5	36x10
M15x1.5	1.5	36x10
M16x1	1	41x14
M16x1.5	1.5	41x14

Size	Pitch	Outside
M17x1.5	1.5	41x14
M18x1	1	41x14
M18x1.5	1.5	41x14
M18x2	2	41x14
M20x1	1	41x14
M20x1.5	1.5	41x14
M20x2	2	41x14
M22x1	1	50x16
M22x1.5	1.5	50x16
M22x2	2	50x16
M24x1	1	50x16
M24x1.5	1.5	50x16
M24x2	2	50x16
M25x1.5	1.5	50x16
M25x2	2	50x16
M27x1	1	60x18
M27x1.5	1.5	60x18
M27x2	2	60x18
M28x1	1	60x18
M28x1.5	1.5	60x18
M28x2	2	60x18
M30x1	1	60x18
M30x1.5	1.5	60x18
M30x2	2	60x18
M30x3	3	60x22

## STC099, HSS ADJUSTABLE SPLIT DIE

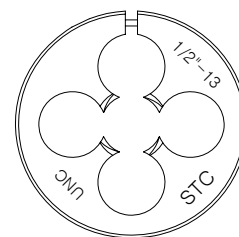

Size	Pitch	Outside	
0	80	13/16"	
1	64		
1	72		
2	56		
2	64		
3	48		
3	56		
4	40		
4	48		
5	40		
5	44		
6	32		13/16"
6	40		
8	32		
8	36		
10	24		
10	32		
12	24		
12	28		
1/4"	20		
1/4"	28		
5/16"	18		
5/16"	24		

Size	Pitch	Outside	
0	80	13/16"	
1	64		
1	72		
2	56		
2	64		
3	48		
3	56		
4	40		
4	48		
5	40		
5	44		
6	32		13/16"
6	40		
8	32		
8	36		
10	24		
10	32		
12	24		
12	28		
1/4"	20		
1/4"	28		
5/16"	18		
5/16"	24		

Size	Pitch	Outside	
0	80	13/16"	
1	64		
1	72		
2	56		
2	64		
3	48		
3	56		
4	40		
4	48		
5	40		
5	44		
6	32		13/16"
6	40		
8	32		
8	36		
10	24		
10	32		
12	24		
12	28		
1/4"	20		
1/4"	28		
5/16"	18		
5/16"	24		

## STC099, HSS ADJUSTABLE SPLIT DIE

Size	Pitch	Outside
6	32	1"
6	40	
8	32	
8	36	
10	24	
10	32	
12	24	
12	28	
1/4"	20	

Size	Pitch	Outside
1/4"	28	1"
5/16"	18	
5/16"	24	
3/8"	16	
3/8"	24	
7/16"	14	
7/16"	20	
1/2"	13	
1/2"	20	

Size	Pitch	Outside
1/4"	20	1-1/2"
1/4"	28	
5/16"	18	
5/16"	24	
3/8"	16	
3/8"	24	
7/16"	14	
7/16"	20	

Size	Pitch	Outside
1/2"	13	1-1/2"
1/2"	20	
9/16"	12	
9/16"	18	
5/8"	11	
5/8"	18	
3/4"	10	
3/4"	16	

Size	Pitch	Outside
1/4"		2"
1/4"	28	
5/16"	18	
5/16"	24	
3/8"	16	
3/8"	24	
7/16"	14	
7/16"	20	
1/2"	13	
1/2"	20	

Size	Pitch	Outside
9/16"	12	2"
9/16"	18	
5/8"	11	
5/8"	18	
3/4"	10	
3/4"	16	
7/8"	9	
7/8"	14	
1"	8	
1"	12	

Size	Pitch	Outside
3/4"	10	2-1/2"
3/4"	16	
7/8"	9	
7/8"	14	
1"	8	
1"	12	
1-1/8"	7	

Size	Pitch	Outside
1-1/8"	12	2-1/2"
1-1/4"	7	
1-1/4"	12	
1-3/8"	6	
1-3/8"	12	
1-1/2"	6	
1-1/2"	12	

## STC100A, ADJUSTABLE ROUND PIPE DIE

Material: HSS, Carbon steel. Standard Thread, Right Hand

NPT & NPS

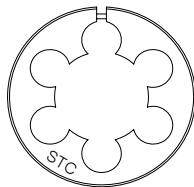

Size	Pitch	Outside
1/16	27	1"
1/8	27	1"
1/8	27	1-1/2"
1/4	18	1-1/2"
3/8	18	1-1/2"
1/2	14	2"
3/4	14	2"

Size	Pitch	Outside
1	11-1/2	2-1/2"
1-1/4	11-1/2	3"
1-1/2	11-1/2	3-1/2"
2	11-1/2	4"
2-1/2	8	5"
3	8	5"
3-1/2	8	6"

## STC100B, SPECIAL THREAD ROUND ADJUSTABLE DIES

Size	Pitch ( T.P.I )	Outside
6	36, 45, 56	1"
8	24, 40, 48, 56	
1/4"	24, 26, 27, 30, 32, 36, 40, 48, 56	
5/16"	20, 22, 27, 32, 36, 40, 48	
3/8"	14, 18, 20, 26, 27, 28, 32, 36, 40, 48	
7/16"	18, 24, 27, 28, 32, 40	
1/2"	12, 14, 16, 18, 24, 28, 32, 36, 40, 48	
9/16"	14, 16, 20, 24, 27, 28, 32, 36, 40	
5/8"	12, 14, 16, 20, 24, 26, 27, 28, 32, 36, 40, 48	
11/16"	12, 18, 20, 24, 32, 36, 40	
3/4"	12, 14, 18, 20, 24, 26, 27, 28, 32, 36, 40, 48	
13/16"	10, 12, 14, 16, 18, 20, 24, 32	
7/8"	12, 14, 16, 18, 20, 24, 27, 28, 32, 40	
15/16"	12, 16, 18, 20, 24, 27, 32	
1"	10, 16, 18, 20, 24, 26, 27, 28, 32, 36, 40, 48	
1-1/16"	8, 10, 12, 14, 16, 18, 20, 24, 28	
1-1/8"	8, 10, 14, 16, 18, 20, 24, 27, 32	
1-3/16"	8, 12, 14, 16, 18, 20, 24, 32	
1-1/4"	8, 10, 14, 16, 18, 20, 24, 27, 32, 36, 40	
1-5/16"	8, 12, 14, 16, 18, 20, 24, 27, 32	
1-3/8"	8, 10, 14, 16, 18, 20, 24, 27, 32	
1-7/16"	8, 12, 16, 18	
1-1/2"	8, 10, 14, 16, 18, 24, 32	
1-9/16"	8, 12, 16, 18	
1-5/8"	5-1/2, 8, 10, 12, 14, 18, 20	
1-11/16"	8, 12, 16, 18	
1-3/4"	6, 8, 10, 14, 16, 20, 24	
1-7/8"	5, 8, 10, 12, 14, 16, 18, 20	
2"	6, 8, 10, 14, 16, 18, 20, 24	
2-1/8"	18	
2-1/4"	8, 12	
2-1/2"	12	

## STC100C, HEXAGON RETHREADING DIES

Material: Alloy Steel. Carbon Steel. HSS. Right Hand

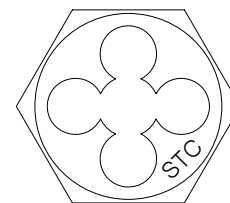

Standard Sizes

Size	Pitch	Outside
1/4"	20	19/32"
1/4"	28	
5/16"	18	11/16"
5/16"	24	
3/8"	16	25/32"
3/8"	24	
7/16"	14	7/8"
7/16"	20	
1/2"	13	1-1/16"
1/2"	20	
9/16"	12	
9/16"	18	
5/8"	11	1-1/4"
5/8"	18	

Size	Pitch	Outside
3/4"	10	1-7/16"
3/4"	16	
7/8"	9	1-5/8"
7/8"	14	
1"	8	1-13/16"
1"	12	
1-1/8"	7	2"
1-1/8"	12	
1-1/4"	7	2-3/16"
1-1/4"	12	
1-3/8"	6	2-3/8"
1-3/8"	12	
1-1/2"	6	2-9/16"
1-1/2"	12	

## STC100C, HEXAGON RETHREADING DIES

Material: Alloy Steel. Carbon Steel. High Speed Steel. Right Hand

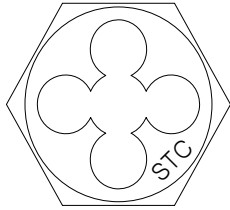

Special Thread

Size	Pitch	Outside
1-1/8"	8	2"
1-1/8"	16	
1-1/8"	18	
1-1/4"	8	2-3/16"
1-1/4"	16	
1-1/4"	18	
1-3/8"	8	2-3/8"
1-3/8"	16	
1-3/8"	18	
1-1/2"	8	2-9/16"
1-1/2"	16	
1-1/2"	18	
1-5/8"	5-1/2	3-1/8"
1-5/8"	8	
1-5/8"	12	
1-5/8"	16	
1-5/8"	18	
1-5/8"	18	
1-3/4"	5	3-1/8"
1-3/4"	8	
1-3/4"	12	
1-3/4"	16	
1-3/4"	18	3-1/8"
1-7/8"	5	
1-7/8"	8	
1-7/8"	12	
1-7/8"	16	3-1/8"
1-7/8"	18	
2"	4-1/2	3-1/2"
2"	8	
2"	12	
2"	16	
2"	18	
2-1/8"	8	3-1/2"

Size	Pitch	Outside
2-1/8"	12	3-1/3"
2-1/4"	4-1/2	3-1/2"
2-1/4"	8	
2-1/4"	12	
2-1/4"	16	
2-1/4"	18	4-1/2"
2-3/8"	8	
2-3/8"	12	
2-1/2"	4	4-1/2"
2-1/2"	8	
2-1/2"	12	
2-5/8"	8	4-1/2"
2-5/8"	12	
2-3/4"	4	4-1/2"
2-3/4"	8	
2-3/4"	12	
2-3/4"	12	
2-7/8"	8	4"
2-7/8"	12	
3"	4	4"
3"	8	
3"	12	4"
3-1/4"	4	
3-1/4"	8	
3-1/4"	12	
3-1/2"	4	4"
3-1/2"	8	
3-1/2"	12	4"
3-3/4"	4	
3-3/4"	8	
3-3/4"	12	4"
4"	4	
4"	8	

## STC100C, HEXAGON RETHREADING DIES

Material: Alloy Steel. Carbon Steel. High Speed Steel.

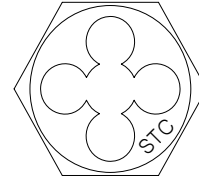

Left Hand

Size	Pitch	Outside
1/4"	20	19/32"
1/4"	28	
5/16"	18	11/16"
5/16"	24	
3/8"	16	25/32"
3/8"	24	
7/16"	14	7/8"
7/16"	20	
1/2"	13	1-1/16"
1/2"	20	
9/16"	12	
9/16"	18	
5/8"	11	1-1/4"
5/8"	18	

Size	Pitch	Outside
3/4"	10	1-7/16"
3/4"	16	
7/8"	9	1-5/8"
7/8"	14	
1"	8	1-13/16"
1"	12	
1-1/8"	7	
1-1/8"	12	2"
1-1/4"	7	
1-1/4"	12	2-3/16"
1-3/8"	6	
1-3/8"	12	2-3/8"
1-1/2"	6	
1-1/2"	12	2-9/16"

## STC102, TAP WRENCH



STC102-1, Metric Size, DIN1814

Size	Length	For Taps
0	125	M1-8
1	180	M1-10
1-1/2	180/200	M1-12
2	280	M4-12

Size	Length	For Taps
3	380	M5-20
4	500	M9-27
5	750	M13-32

STC102-2, Adjustable Tap & Reamer Wrench, Inch Sizes.

Size	Tap Capacity	Screw Capacity	Reamer Capacity	Pipe Capacity	Total Length
0	1/16-1/4"	0-14	1/8-21/64"	--	7"
5	5/32-1/2"	7-14	11/64-7/16"	1/8"-1/4"	11"
6	5/32-3/4"	7-14	11/64-41/64"	1/8-1/4"	15"
7	1/4-1.1/8"	--	9/32-29/32"	1/8-3/4"	19"
8	3/4-1.5/8"	--	37/94-1.11/32"	3/8-1.1/4"	40"

## STC100C, HEXAGON RETHREADING DIES

Material: Alloy Steel. Carbon Steel. High Speed Steel. Right Hand

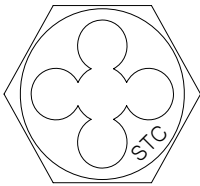

NPT Pipe Thread

Size	Pitch	Outside
1/8"	27	25/32"
1/4"	18	1-1/16"
3/8"	18	1-1/4"

Size	Pitch	Outside
1/2"	14	1-7/16"
3/4"	14	1-13/16"
1"	11-1/2"	2-3/16"

## STC103-1, DIE STOCK, DIN225



Size	Length	For Dies
16x5	160	M1-2.6
20x5	200	M3-4
20x7	200	M4.5-6
25x9	210	M7-9
30x11	280	M10-11

Size	Length	For Dies
38X14	315	M12-14
45X18	450	M16-20
55X22	560	M22-24
65X25	630	M27-36

## STC103-2, DIE STOCK ( INCH SIZE FOR ADJUSTABLE ROUND SPLIT DIES)

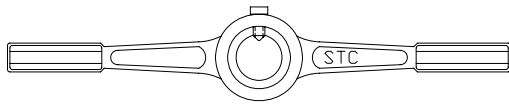

For Adjustable Round Split Dies

Dies Outersize	Length	Dies Outersize	Length\
5/8"	6"	2-1/2"	19"
13/16"	6-1/4"	3"	22"
1"	9"	3-1/2"	24"
1-1/2"	12"	4"	29"
2"	15"		

## STC104, T HANDLE TAP WRENCH

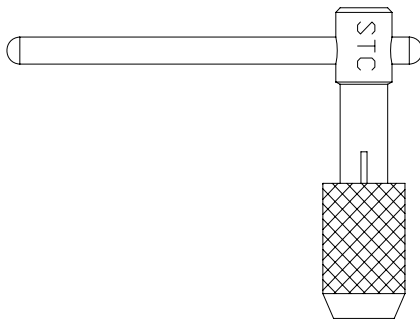

T handle Tap Wrench, Plain Type

For Metric 2 Sizes available: M3 - M6, M6 - M12.
For Inch, 2 sizes available: 1/16" - 1/4", 5/16" - 1/2"

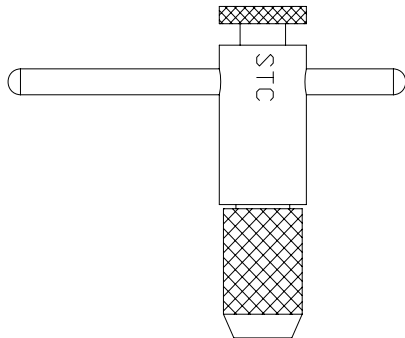

T Handle Tap Wrench, Ratchet Type

Size	Metric	Inch	Pipe	Length
1	M3 - M10	1/8" - 3/8"		85mm
2	M5 - M12	7/32" - 1/2"	G1/8	100mm
10	M 3 - M10	1/8" - 3/8"		250mm
20	M5 - M12	7/32" - 1/2"	G1/8	300mm

## STC106A, SCREW EXTRACTOR

### Heavy Duty

Set Available

5pcs/set	1# - 5#
6pcs/set	1# - 6#
8pcs / set	1# - 8#

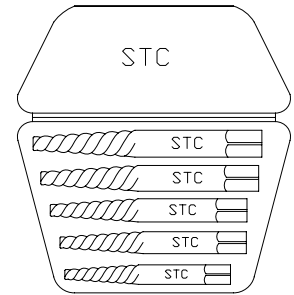

Individual Sizes

Size	Metric	Inch
1#	M3 - M6	1/8" - 1/4"
2#	M6 - M8	1/4" - 5/16"
3#	M8 - M11	5/16" - 7/16"
4#	M11 - M14	7/16" - 9/16"
5#	M14 - M18	9/16" - 3/4"
6#	M18 - M24	3/4" - 1"
7#	M24 - M30	1" - 1.13/16"
8#	M30 - M40	13/16" - 1.37/64"

## STC106B, SCREW EXTRACTOR

### Light Duty

Set Available

5pcs/set	1# - 5#
6pcs/set	1# - 6#
8pcs / set	1# - 8#

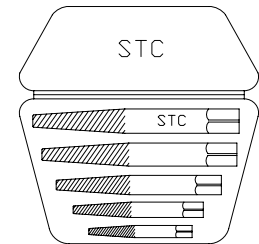

Individual Sizes

Size	Metric	Inch
1#	M3 - M6	1/8" - 1/4"
2#	M6 - M8	1/4" - 5/16"
3#	M8 - M11	5/16" - 7/16"
4#	M11 - M14	7/16" - 9/16"
5#	M14 - M18	9/16" - 3/4"
6#	M18 - M24	3/4" - 1"
7#	M24 - M30	1" - 1.13/16"
8#	M30 - M40	13/16" - 1.37/64"

## STC107 12PCS/SET DRILL & SCREW EXTRACTOR SET

HSS Drill Sizes:

2, 3, 4, 5, 7, 10mm

Extractor Sizes:

1#, 2#, 3#, 4#, 5#, 6#

With Plastic Box

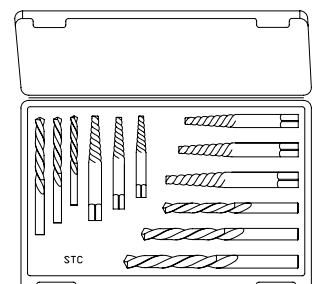

## STC114B, CARBON STEEL 40PCS/SET TAP & DIE, METRIC SIZES

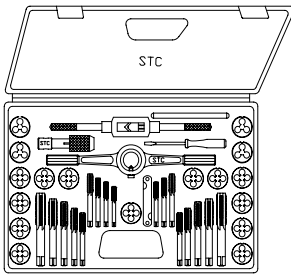

DESCRIPTION
● 8pcs Taps M3-M12 . Standard Thread.
● 8pcs Taps M3-M12 . Fine Thread
● 1PC NPT Tap: 1/8-27.
● 8pcs Dies M3-M12 . Standard Thread.
● 8pcs Dies M3-M12 . Fine Thread
● 1PC NPT Die: 1/8-27.
● 1PC Wrench-American patten 1/2"
● 1PC "T" type Tap Wrench 1/4"
● 1PC Die handle 1" outside.
● 1PC Screwdriver.
● 1PC Screw Pitch Gauge.

Taps		Dies	
3x0.6	3x0.5	3x0.6	3x0.5
4x0.75	4x0.7	4x0.75	4x0.7
5x0.9	5x0.8	5x0.9	5x0.8
6x1	6x0.75	6x1	6x0.75
7x1	7x0.75	7x1	7x0.75
8x1.25	8x1	8x1.25	8x1
10x1.5	10x1	10x1.5	10x1
12x1.75	12x1.5	12x1.75	12x1.5

## STC114A, CARBON STEEL 40PCS/SET TAP & DIE, INCH SIZES

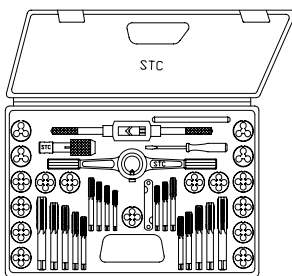

DESCRIPTION
● 10 PCS UNC DIES.
● 6 PCS UNF DIES
● 1PC NPT DIE: 1/8-27
● 10 PCS UNC TAPS
● 6 PCS UNF TAPS
● 1PC NPT TAP: 1/8-27
● 1PC Wrench-American patten 1/2"
● 1PC "T" type Tap Wrench 1/4"
● 1PC Die handle 1" outside.
● 1PC Screwdriver.
● 1PC Screw Pitch Gauge.

UNC Dies	UNF Dies	UNC Taps	UNF Taps
4-40	10-32	4-40	10-32
6-32	1/4"-28	6-32	1/4"-28
8-32	5/16"-24	8-32	5/16"-24
10-24	3/8"-24	10-24	3/8"-24
1/4"-20	7/16"-20	1/4"-20	7/16"-20
5/16"-18	1/2"-20	5/16"-18	1/2"-20
3/8"-16		3/8"-16	
7/16"-14		7/16"-14	
1/2"-13		1/2"-13	

## STC115B, LARGE SIZES 45PCS/SET TAP & DIE SET, METRIC SIZES

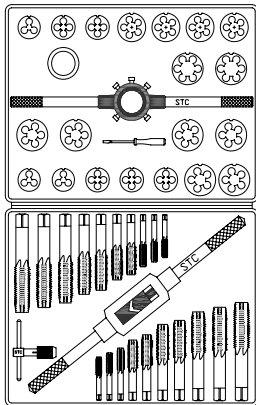

DESCRIPTION
● 10pcs Taps M6 - M24, Standard Thread.
● 10pcs Taps M6 - M24, Fine Thread.
● 10pcs Dies M6 - M24, Standard Thread.
● 10pcs Dies M6 - M24, Fine Thread.
● 1pc Tap Wrench
● 1pc "T" type Tap Wrench
● 1pc Die handle 2" outside with adapter
● 1pc Screwdriver

Taps		Dies	
6x1	6x0.75	6x1	6x0.75
8x1.25	8x1	8x1.25	8x1
10x1.5	10x1.25	10x1.5	10x1.25
12x1.75	12x1.5	12x1.75	12x1.5
14x2	14x1.5	14x2	14x1.5
16x2	16x1.5	16x2	16x1.5
18x2.5	18x1.5	18x2.5	18x1.5
20x2.5	20x1.5	20x2.5	20x1.5
22x2.5	22x1.5	22x2.5	22x1.5
24x3	24x1.5	24x3	24x1.5

☆ Carbon Steel, Cut Thread.  
please Specify when ordering HSS Ground Thread

## STC115A, LARGE SIZES 45PCS/SET TAP & DIE SET, INCH SIZES

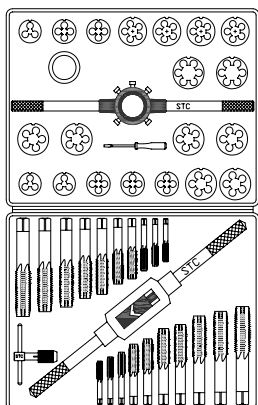

DESCRIPTION
● 10pcs UNC Taps: 1/4"-1".
● 10pcs UNF Taps: 1/4"-1".
● 10pcs UNC Dies: 1/4"-1".
● 10pcs UNF Dies: 1/4"-1".
● 1pc Tap Wrench
● 1pc "T" type Tap Wrench
● 1pc Die handle 2" outside with adapter
● 1pc Screwdriver

Taps		Dies	
UNC	UNF	UNC	UNF
1/4"-20	1/4"-28	1/4"-20	1/4"-28
5/16"-18	5/16"-24	5/16"-18	5/16"-24
3/8"-16	3/8"-24	3/8"-16	3/8"-24
7/16"-14	7/16"-20	7/16"-14	7/16"-20
1/2"-13	1/2"-20	1/2"-13	1/2"-20
9/16"-12	9/16"-18	9/16"-12	9/16"-18
5/8"-11	5/8"-18	5/8"-11	5/8"-18
3/4"-10	3/4"-16	3/4"-10	3/4"-16
7/8"-9	7/8"-14	7/8"-9	7/8"-14
1"-8	1"-12	1"-8	1"-12

☆ Carbon Steel, Cut Thread.  
please Specify when ordering HSS Ground Thread

## STC116-1, CARBON STEEL 60PCS TAP & DIE SETS

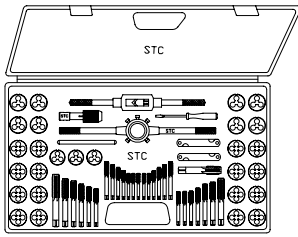

DESCRIPTION
● 10pcs Metric Taps: M3-M12
● 10pcs Metric Dies: M3-M12.
● 10pcs UNC Taps: 4-40 to 1/2"-13
● 10pcs UNC Dies: 40-40 to 1/2"-13
● 6pcs UNF Tpas.
● 6pcs UNF Dies.
● NPT Dies: 1/8-27.
● NPT Taps: 1/8-27.
● 1pc Tap Wrench-American patten 1/2" capacity.
● 1pc "T" Type Tap Wrench 1/4" capacity.
● 1pc Die handle 1" outside.
● 1pc Screwdriver.
● 2pcs Screw Pitch Gauge.

☆ Carbon Steel, Cut Thread.

Metric Taps		Metric Dies	
3x0.5	8x1.25	3x0.5	8x1.25
4x0.7	9x1.25	4x0.7	9x1.25
5x0.8	10x1.5	5x0.8	10x1.5
6x1	10x1	6x1	10x1
7x1	12x1.75	7x1	12x1.75
UNC Taps		UNC Dies	
4-40	1/4"-20	4-40	1/4"-20
6-32	5/16"-18	6-32	5/16"-18
8-28	3/8"-16	8-28	3/8"-16
10-24	7/16"-14	10-24	7/16"-14
12-24	1/2"-13	12-24	1/2"-13
UNF Taps		UNF Dies	
10-32	3/8"-24	10-32	3/8"-24
1/4"-28	7/16"-20	1/4"-28	7/16"-20
5/16"-24	1/2"-20	5/16"-24	1/2"-20

## STC117A, 110PCS/SET TAP & DIE SETS, METRIC SIZE (M2-M18)

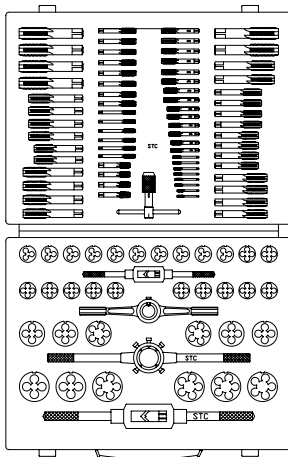

DESCRIPTION
● 35sets Taps: M2-M18, DIN2181 2pc/set.
● 35pcs Dies: M2 - M18, DIN223.
Dies Outside Diameter: 25.4 / 38.1mm.
● 1pcs Tap Wrench 190mm.
● 1pcs Tap Wrench 380mm.
● 1pcs Die Stock for 25.4mm
● 1pcs Die Stock for 38.1mm.
● 1pc T Type Tap Wrench.

☆ Carbon Steel, Cut Steel.  
Please specify when ordering HSS Ground Steel

DIN2181 Taps		DIN223 Dies	
M2x0.4	M11x0.75	M2x0.4	M11x0.75
M3x0.5	M11x1	M3x0.5	M11x1
M4x0.7	M11x1.25	M4x0.7	M11x1.25
M5x0.8	M11x1.5	M5x0.8	M11x1.5
M6x0.75	M12x0.75	M6x0.75	M12x0.75
M6x1	M12x1	M6x1	M12x1
M7x0.75	M12x1.25	M7x0.75	M12x1.25
M7x1	M12x1.5	M7x1	M12x1.5
M8x0.75	M12x1.75	M8x0.75	M12x1.75
M8x1	M14x1	M8x1	M14x1
M8x1.25	M14x1.25	M8x1.25	M14x1.25
M9x0.75	M14x1.5	M9x0.75	M14x1.5
M9x1	M14x2	M9x1	M14x2
M9x1.25	M16x1	M9x1.25	M16x1
M10x0.75	M16x1.5	M10x0.75	M16x1.5
M10x1	M16x2	M10x1	M16x2
M10x1.25	M18x1.5	M10x1.25	M18x1.5
M10x1.5		M10x1.5	

## STC117B, 110PCS/SET TAP & DIE SETS, INCH / METRIC COMBINATION SIZE

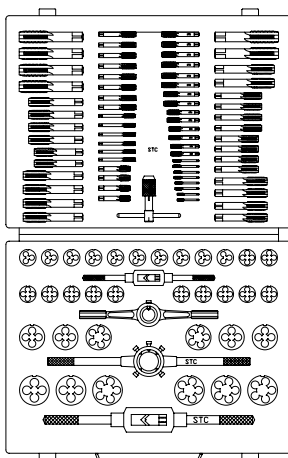

DESCRIPTION
● 35sets Taps, 2pcs each set.
● 35pcs Dies. OD 1" / 2"
● 1pcs Tap Wrench for 1/8"-1/2" ( M3-M12)
● 1pcs Tap Wrench for 3/16"-3/4" ( M5-M20)
● 1pcs Die Stock for 1"
● 1pcs Die Stock for 2".
● 1pc T Type Tap Wrench.

☆ Carbon Steel, Cut Steel.  
Please specify when ordering HSS Ground Steel

TAPS		1" OD Dies	
4-40	9/16"-12	4-40	5/16-24
6-32	9/16"-18	6-32	3/8"-16
8-32	5/8"-11	8-32	3/8"-24
10-24	5/8"-18	10-24	7/16"-14
10-32	3/4"-10	10-32	7/16"-20
12-24	3/4"-16	12-24	M6x1
1/4"-20	1/8"-27NPT	1/4"-20	M8x1.25
1/4"-28	1/4"-18NPT	1/4"-28	M10x1
1/4"-24		1/4"-24	M10x1.5
1/4"-32	M6x1	1/4"-32	M11x1.5
5/16"-18	M8x1.25	5/16"-18	1/8"-27NPT
5/16-24	M10x1	2" OD Dies	
3/8"-16	M10x1.5	1/2"-13	3/4"-16
3/8"-24	M11x1.5	1/2"-20	M12x1.25
7/16"-14	M12x1.25	9/16"-12	M12x1.75
7/16"-20	M12x1.75	9/16"-18	M14x1.25
1/2"-13	M14x1.25	5/8"-11	M18x1.5
1/2"-20	M18x1.5	5/8"-18	1/4"-18NPT
		3/4"-10	



## STC242, T TYPE CUT OFF BLADE

STC242-1, T TYPE CUT OFF BLADE, PARALLEL TYPE

Material: HSS, HSS-Cobalt.

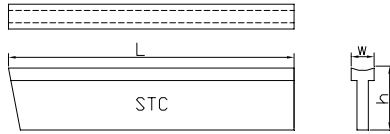

Model	Size w x h x L
P1N	.04" x 1/2" x 3-1/2"
P1	1/16" x 1/2" x 4-1/4"
P2N	5/64" x 1/2" x 4-1/4"
P2	3/32" x 1/2" x 4-1/4"
P3S	1/8" x 1/2" x 4-1/4"
P3N	3/32" x 11/16" x 5"
P3	1/8" x 11/16" x 5"
P4	5/32" x 11/16" x 5"
P5S	3/16" x 11/16" x 5"
P3W	1/8" x 3/4" x 5"
P4W	15/32" x 3/4" x 5"

Model	Size w x h x L
P5W	3/16" x 3/4" x 5"
P5X	1/8" x 7/8" x 6"
P5N	5/32" x 7/8" x 6"
P5	3/16" x 7/8" x 6"
P6	1/4" x 7/8" x 6"
P8	1/8" x 1-1/8" x 6-1/2"
P8X	5/32" x 1-1/8" x 6-1/2"
P8N	3/16" x 1-1/8" x 6-1/2"
P9	1/4" x 1-1/8" x 6-1/2"
P10	5/16" x 1-1/8" x 6-1/2"

## STC241, HSS CUT OFF BLADE

STC241-1, A TYPE HSS CUT OFF BLADE

Material: HSS, HSS-Cobalt.

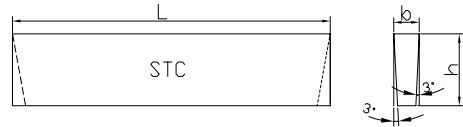

Size b x h x L
1/16" x 1/2" x 4-1/2"
1/16" x 11/16" x 5"
3/32" x 1/2" x 4-1/2"
3/32" x 5/8" x 5"
3/32" x 11/16" x 5"
3/32" x 3/4" x 5"
1/8" x 1/2" x 4-1/2"
1/8" x 5/8" x 5"
1/8" x 11/16" x 5"
1/8" x 3/4" x 5"
1/8" x 7/8" x 6"
1/8" x 1" x 6"

Size b x h x L
5/32" x 5/8" x 6"
5/32" x 3/4" x 6"
5/32" x 7/8" x 6"
5/32" x 1" x 6"
3/16" x 3/4" x 6"
3/16" x 1" x 6"
3/16" x 1-1/8" x 7"
3/16" x 1-1/4" x 7"
1/4" x 1" x 6"
1/4" x 1-1/4" x 7"
1/4" x 1-3/8" x 7"

## STC242-2, T TYPE CUT OFF BLADE, TAPERED TYPE

Material: HSS, HSS-Cobalt

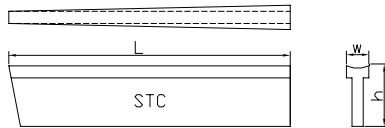

Model	Size w x h x L
T1-N	.04" x 1/2" x 3-1/2"
T-1	1/16" x 1/2" x 4-1/4"
T2-N	5/64" x 1/2" x 4-1/4"
T2	3/32" x 1/2" x 4-1/4"
T3-S	1/8" x 1/2" x 4-1/4"
T3-N	3/32" x 11/16" x 5"
T3	1/8" x 11/16" x 5"
T4	5/32" x 11/16" x 5"
T5-S	3/16" x 11/16" x 5"
T3-W	1/8" x 3/4" x 5"
T4-W	15/32" x 3/4" x 5"

Model	Size w x h x L
T5-W	3/16" x 3/4" x 5"
T5-X	1/8" x 7/8" x 6"
T5-N	5/32" x 7/8" x 6"
T5	3/16" x 7/8" x 6"
T6	1/4" x 7/8" x 6"
T8-X	1/8" x 1-1/8" x 6-1/2"
T8-N	5/32" x 1-1/8" x 6-1/2"
T8	3/16" x 1-1/8" x 6-1/2"
T9	1/4" x 1-1/8" x 6-1/2"
T10	5/16" x 1-1/8" x 6-1/2"

## STC241-2, B TYPE HSS CUT OFF BLADE

Material: HSS, HSS-Cobalt.

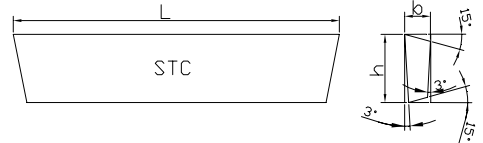

Size b x h x L
1/16" x 1/2" x 4-1/2"
1/16" x 11/16" x 5"
3/32" x 1/2" x 4-1/2"
3/32" x 5/8" x 5"
3/32" x 11/16" x 5"
3/32" x 3/4" x 5"
1/8" x 1/2" x 4-1/2"
1/8" x 5/8" x 5"
1/8" x 11/16" x 5"
1/8" x 3/4" x 5"
1/8" x 7/8" x 6"
1/8" x 1" x 6"

Size b x h x L
5/32"x5/8" x 6"
5/32"x3/4" x 6"
5/32"x7/8" x 6"
5/32"x1" x 6"
3/16"x3/4" x 6"
3/16"x1" x 6"
3/16"x1-1/8" x 7"
3/16"x-1/4" x 7"
1/4"x1" x 6"
1/4"x1-1/4" x 7"
1/4"x1-3/8" x 7"

## STC121, MODULE INVOLUTE GEAR CUTTER

20° Pressure Angle, High Speed Steel.

Cutter List for M1 - M8.		Cutter List for M9 - M16			
cutter Number	Range of Teeth Cut	cutter Number	Range of Teeth Cut	cutter Number	Range of Teeth Cut
# 1	12 - 13	# 1	12	# 9	26 - 29
# 2	14 - 16	# 2	13	# 10	30 - 34
# 3	17 - 20	# 3	14	# 11	35 - 41
# 4	21 - 25	# 4	15 - 16	# 12	42 - 54
# 5	26 - 34	# 5	17 - 18	# 13	55 - 79
# 6	35 - 54	# 6	19 - 20	# 14	80 - 134
# 7	55 - 134	# 7	21 - 22	# 16	135 to rack
# 8	135 to rack	# 8	23 - 25		

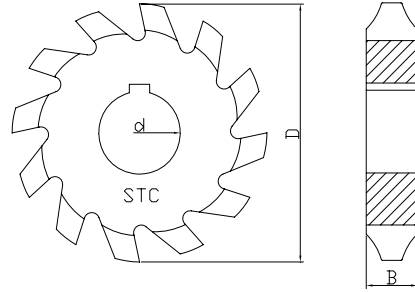

### MODULE INVOLUTE GEAR CUTTER, CUTTER NUMBER #1 - #8.

Module	Cutter Diameter	Arbor Hole	Thickness ( mm )							
			1#	2#	3#	4#	5#	6#	7#	8#
0.3	40	16	4	4	4	4	4	4	4	4
0.35	40	16	4	4	4	4	4	4	4	4
0.4	40	16	4	4	4	4	4	4	4	4
0.5	40	16	4	4	4	4	4	4	4	4
0.6	40	16	4	4	4	4	4	4	4	4
0.7	40	16	4	4	4	4	4	4	4	4
0.8	40	16	4	4	4	4	4	4	4	4
0.9	40	16	4	4	4	4	4	4	4	4
1	50	22	4	4	4	4	4	4	4	4
1.25	50	22	4.8	4.6	4.4	4.2	4.1	4	4	4
1.5	55	22	5.6	5.4	5.2	5.1	4.9	4.7	4.5	4.2
1.75	60	22	6.5	6.3	6	5.8	5.6	5.4	5.2	4.9
2	60	22	7.3	7.1	6.8	6.6	6.3	6.1	5.9	5.5
2.25	60	22	8.2	7.9	7.6	7.3	7.1	6.8	6.5	6.1
2.5	65	22	9	8.7	8.4	8.1	7.8	7.5	7.2	6.8
2.75	70	27	9.9	9.6	9.2	8.8	8.5	8.2	7.9	7.4
3	70	27	10.7	10.4	10	9.6	9.2	8.9	8.5	8.1
3.25	75	27	11.5	11.2	10.7	10.3	9.9	9.6	9.3	8.8
3.5	75	27	12.4	12	11.5	11.1	10.7	10.3	9.9	9.4
3.75	80	27	13.3	12.8	12.3	11.9	11.4	11	10.5	10
4	80	27	14.1	13.7	13.1	12.6	12.2	11.7	11.2	10.7
4.5	80	27	15.3	14.9	14.4	13.9	13.6	13.1	12.6	12
5	90	32	16.8	16.3	15.8	15.4	14.9	14.5	13.9	13.2
5.5	95	32	18.4	17.9	17.3	16.7	16.3	15.8	15.3	14.5
6	100	32	19.9	19.4	18.8	18.1	17.6	17.1	16.4	15.7
6.5	105	32	21.4	20.8	20.2	19.4	19	18.4	17.8	17
7	105	32	22.9	22.3	21.6	20.9	20.3	19.7	19	18.2
8	110	32	26.1	25.3	24.4	23.7	23	22.3	21.5	20.7
9	115	32	29.2	28.7	28.3	28.1	27.6	27	26.6	26.1
10	120	40	32.2	31.7	31.2	31	30.4	29.8	29.3	28.7
11	135	40	35.3	34.8	34.3	34	33.3	32.7	31.2	31.5
12	145	40	38.3	37.7	37.2	36.9	36.1	35.5	35	34.3
14	160	40	44.7	44	43.4	43	42.1	41.3	40.6	39.8
16	170	40	50.7	49.9	49.3	48.7	47.8	46.8	46.1	45.1

### MODULE 9 - 16 INVOLUTE GEAR CUTTER, CUTTER NUMBER #9 - #15.

Module	Cutter Diameter	Arbor Hole	Thickness							In set
			9#	10#	11#	12#	13#	14#	15#	
9	115	32	25.9	25.4	25.1	24.7	24.3	23.9	23.3	1#-15#
10	120	40	28.5	28	27.6	27.2	26.7	26.3	25.7	1#-15#
11	135	40	31.3	30.7	30.3	29.9	29.3	28.9	28.2	1#-15#
12	145	40	34	33.4	33	32.4	31.7	31.3	30.6	1#-15#
14	160	40	39.5	38.8	38.4	37.7	37	36.3	35.5	1#-15#
16	170	40	44.8	43.5	43.5	42.8	41.9	41.3	40.3	1#-15#

## STC122, GEAR HOBS, DIN8002

20° Pressure Angle, HSS, Bright & Tin-coated.

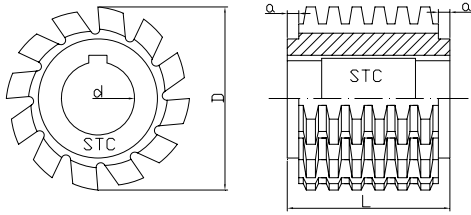

Module	Diameter	Arbor Hole	Length	a
1	50	22	32	4
1.25	50	22	40	4
1.5	63	27	50	4
1.75	63	27	50	4
2	63	27	50	4
2.25	71	27	56	4
2.5	71	27	63	4
2.75	71	27	63	4
3	80	32	71	4
3.25	80	32	71	4
3.5	80	32	71	4
3.75	90	32	80	4
4	90	32	80	4
4.5	90	32	90	4
5	100	32	100	4
5.5	112	40	112	4
6	112	40	112	4
6.5	118	40	118	4
7	118	40	125	5
8	125	40	132	5
9	140	40	150	5
10	150	50	170	5

## STC131, HEXAGON PUSH BROACHES

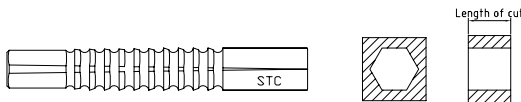

Hex Size	Overall Length	Pilot Size	Drill Size	Length of Cut
1/8"	4-1/8"	1/8"	1/8"	3/16" - 3/8"
5/32"	4-15/16"	5/32"	5/32"	1/4" - 1/2"
3/16"	5-1/16"	3/16"	3/16"	1/4" - 5/8"
7/32"	5-3/8"	7/32"	7/32"	1/4" - 3/4"
1/4"	6"	1/8"	1/8"	5/16" - 3/4"
9/32"	7-1/4"	9/32"	9/32"	3/8" - 1"
5/16"	7-3/4"	5/16"	5/16"	3/8" - 1"
11/32"	7-3/4"	11/32"	11/32"	3/8" - 1-1/4"
3/8"	8-1/2"	3/8"	3/8"	1/2" - 1-1/4"
13/32"	9-5/8"	13/32"	13/32"	1/2" - 1-3/8"
7/16"	10-5/8"	7/16"	7/16"	1/2" - 1-3/8"
15/32"	11-7/8"	15/32"	15/32"	1/2" - 1-3/8"
1/2"	11-7/8"	1/2"	1/2"	1/2" - 1-3/8"
9/16"	13-3/4"	9/16"	9/16"	5/8" - 1-5/8"
5/8"	16-1/4"	5/8"	5/8"	5/8" - 2"
11/16"	16-3/4"	11/16"	11/16"	5/8" - 2"
3/4"	17-1/4"	3/4"	3/4"	5/8" - 2"
7/8"	18-1/2"	7/8"	7/8"	5/8" - 2"
1"	19-3/4"	1"	1"	5/8" - 2"

## STC132, HEXAGON PUSH BROACHES

Hex Size	Length Overall	Pilot Size	Drill Size	Length of Cut
4 mm	140 mm	4 mm	4 mm	6.3 - 13 mm
5 mm	152 mm	5 mm	5 mm	6.3 - 19 mm
6 mm	162 mm	6 mm	6 mm	6.3 - 19 mm
7 mm	197 mm	7 mm	7 mm	9.5 - 25 mm
8 mm	210 mm	8 mm	8 mm	9.5 - 25 mm
10 mm	254 mm	10 mm	10 mm	12.7 - 35 mm
12 mm	314 mm	12 mm	12 mm	12.7 - 35 mm
14 mm	362 mm	14 mm	14 mm	12.7 - 38 mm
16 mm	428 mm	16 mm	16 mm	16.0 - 41 mm
18 mm	432 mm	18 mm	18 mm	16.0 - 41 mm
20 mm	454 mm	20 mm	20 mm	16.0 - 41 mm
22 mm	479 mm	22 mm	22 mm	16.0 - 41 mm
24 mm	505 mm	24 mm	24 mm	16.0 - 41 mm
25 mm	505 mm	25 mm	25 mm	16.0 - 41 mm

## STC133, SQUARE PUSH BROACHES

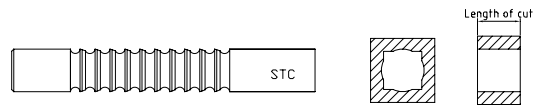

Square Size	Overall Length	Pilot Size	Drill Size	Length of Cut
1/8"	4-1/8"	0.1285"	30#	3/16" - 1/2"
5/32"	5-1/8"	0.159	21#	1/4" - 1/2"
3/16"	5-9/16"	0.1935	10#	1/4" - 5/8"
7/32"	6-3/8"	0.228	1#	1/4" - 3/4"
1/4"	6-1/2"	17/64"	17/64"	1/4" - 3/4"
9/32"	7-3/4"	19/64"	19/64"	5/16" - 1"
5/16"	7-7/8"	21/64"	21/64"	5/16" - 1"
11/32"	9-3/8"	23/64"	23/64"	3/8" - 1-1/4"
3/8"	9-3/8"	25/64"	25/64"	3/8" - 1-1/4"
13/32"	105/8"	27/64"	27/64"	1/2" - 1-3/8"
7/16"	107/8"	29/64"	29/64"	1/2" - 1-3/8"
15/32"	12"	1/2"	1/2"	1/2" - 1-3/8"
1/2"	12"	17/32"	17/32"	1/2" - 1-3/8"
9/16"	14-3/4"	19/32"	19/32"	1/2" - 1-1/2"
5/8"	16-5/16"	21/32"	21/32"	5/8" - 1-5/8"
11/16"	17-3/4"	3/4"	3/4"	5/8" - 1-5/8"
3/4"	17-3/4"	13/16"	13/16"	5/8" - 1-5/8"
7/8"	22-3/4"	15/16"	15/16"	1/2" - 2"
1"	24-1/8"	1-3/32"	1-3/32"	1/2" - 2"

Square Size	Overall Length	Pilot Size	Drill Size	Length of Cut
4 mm	141 mm	4.2 mm	4.2 mm	8.0 - 16 mm
5 mm	175 mm	5.2 mm	5.2 mm	9.5 - 19 mm
6 mm	178 mm	6.3 mm	6.3 mm	9.5 - 19 mm
8 mm	208 mm	8.3 mm	8.3 mm	11.0 - 22 mm
10 mm	276 mm	10.3 mm	10.3 mm	12.5 - 25 mm
12 mm	318 mm	12.5 mm	12.5 mm	16.0 - 32 mm
14 mm	378 mm	15 mm	15 mm	19.0 - 38 mm
16 mm	427 mm	17 mm	17 mm	22.0 - 41 mm
18 mm	470 mm	20 mm	20 mm	22.0 - 41 mm
20 mm	480 mm	22 mm	22 mm	22.0 - 41 mm
22 mm	590 mm	24 mm	24 mm	22.0 - 41 mm
24 mm	624 mm	26 mm	26 mm	22.0 - 41 mm
25 mm	624 mm	27 mm	27 mm	22.0 - 41 mm

## STC134, KEYWAY BROACHES

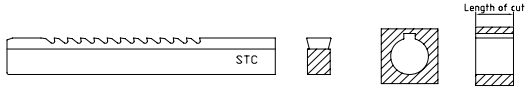

Broach Size	Type	Broach Dimension	Shim	Length of Cut
1/16"	A	1/8x5"	0	13/64" - 1-1/8"
3/32"	A	1/8x5"	0	13/64" - 1-1/8"
1/8"	A	1/8x5"	1	13/64" - 1-1/8"
t3/32"	B	3/16x6-3/4"	0	19/64" - 1-11/16"
1/8"	B	3/16x6-3/4"	1	19/64" - 1-11/16"
5/32"	B	3/16x6-3/4"	1	19/64" - 1-11/16"
3/16"	B	3/16x6-3/4"	1	19/64" - 1-11/16"
3/16"	C	3/8x11-3/4"	1	25/64" - 2-1/2"
1/4"	C	3/8x11-3/4"	1	25/64" - 2-1/2"
5/16"	C	3/8x11-3/4"	2	25/64" - 2-1/2"
3/8"	C	3/8x11-3/4"	2	25/64" - 2-1/2"
5/16"	D	9/16x13-7/8"	2	1" - 6"
3/8"	D	9/16x13-7/8"	2	1" - 6"
7/16"	D	9/16x13-7/8"	3	1" - 6"
1/2"	D	9/16x13-7/8"	3	1" - 6"

Broach Size	Type	Broach Dimension	Shim	Length of Cut
2	A	1/8X5"	0	13/64" - 1-1/8"
3	A	1/8x5"	1	13/64" - 1-1/8"
4	B1	1/4x6-3/4"	1	19/64" - 1-11/16"
5	B1	1/4x6-3/4"	1	19/64" - 1-11/16"
5	C	3/4x11-3/4"	1	25/64" - 2-1/2"
6	C1	3/4x11-3/4"	1	25/64" - 2-1/2"
8	C1	3/4x11-3/4"	2	25/64" - 2-1/2"
10	D1	9/16x13-7/8"	2	1" - 6"
12	D1	9/16x13-7/8"	2	1" - 6"
14	D1	9/16x13-7/8"	2	1" - 6"

## STC134-S, KEYWAY BROACHES SHIMS

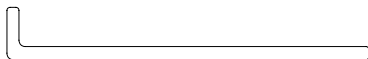

Inch Sizes	Metric Sizes
A 1/8"	A 3mm
B1/8", B5/32", B3/16"	B-1 4mm, B-1 5mm
C3/16", C1/4", C3/8", C5/16"	C 5mm, C1 6mm, C1 8mm
D5/16", D3/8", D1/2", D7/16"	D1 14mm, D1 10 & 12mm
E5/8", E3/4",	E1 16 & 18mm
F7/8", F1"	F1 20 - 25mm

## STC134-B, KEYWAY BROACHES BUSHING

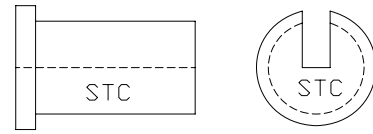

Type	Diameter	Type	Diameter	Type	Diameter
A	1/4"	C	3/4"	C	1-1/2"
A	5/16"	C	13/16"	C	1-9/16"
A	3/8"	C	7/8"	D	1-7/16"
A	7/16"	C	15/16"	D	1-1/2"
A	1/2"	C	1"	D	1-9/16"
B	1/2"	C	1-1/16"	D	1-5/8"
B	9/16"	C	1-1/8"	D	1-11/16"
B	5/8"	C	1-3/16"	D	1-3/4"
B	11/16"	C	1-1/4"	D	1-13/16"
B	3/4"	C	1-5/16"	D	1-7/8"
B	13/16"	C	1-3/8"	D	1-15/16"
B	7/8"	C	1-7/16"	D	2"

### METRIC SIZES

Type	Diameter	Type	Diameter	Type	Diameter
A	6mm	C	18mm	C	36mm
A	8mm	C	19mm	D	32 mm
A	10mm	C	20mm	D	34mm
A	12mm	C	22mm	D	35mm
A	15mm	C	24mm	D	36mm
B1	12mm	C	25mm	D	38mm
B1	14mm	C	26mm	D	40mm
B1	15mm	C	28mm	D	42mm
B1	16mm	C	30mm	D	44mm
B1	17mm	C	32mm	D	45mm
B1	18mm	C	34mm	D	48mm
B1	19mm	C	35mm	D	50mm

## STCDY091-1, MASONRY DRILL, Regular Length

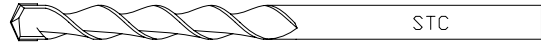

### Metric Sizes, As per DIN8039

Size	Flute Length	Overall Length	Shank Diameter
3	30	60	3
4	40	75	4
5	50	85	5
6	60	100	6
7	70	100	7
8	70	120	8
9	70	120	9
10	80	120	10

Size	Length Flute	Length Overall	Diameter Shank
11	80	150	10
12	80	150	10
13	100	150	10
14	100	150	10
15	100	150	10
16	100	160	13
17	100	160	13
18	100	160	13

Size	Length Flute	Length Overall	Diameter Shank
19	100	160	13
20	100	160	13
21	100	160	13
22	100	160	13
23	100	160	13
24	100	160	13
25	100	160	13
26	100	160	13

### Inch sizes

Size	Flute Length	Overall Length	Shank Diameter
1/8"	1-1/2"	3"	1/8"
5/32"	1-1/2"	3"	5/32"
3/16"	2-1/8"	4"	3/16"
3/16"	4"	6"	3/16"
1/4"	2"	4"	1/4"
1/4"	4"	6"	1/4"
5/16"	2"	4"	1/4"

Size	Length Flute	Length Overall	Diameter Shank
5/16"	4"	6"	1/4"
3/8"	2"	4"	1/4"
3/8"	4"	6"	3/8"
7/16"	2"	4"	1/4"
7/16"	4"	6"	3/8"
1/2"	2"	4"	1/4"
1/2"	2"	6"	1/2"

Size	Length Flute	Length Overall	Diameter Shank
9/16"	4"	6"	3/8"
5/8"	2"	4"	1/4"
5/8"	4"	6"	3/8"
11/16"	4"	6"	1/2"
3/4"	4"	6"	1/2"
7/8"	4"	6"	1/2"
1"	4"	6"	1/2"

## STCDY091-2, MASONRY DRILL, Extra Long Length



### Metric Sizes, mm

Size	Flute Length	Overall Length	Shank Diameter
6	350	400	6
7	350	400	7
8	350	400	8
9	350	400	9
10	350	400	10
11	350	400	10
12	350	400	10
13	350	400	10
14	350	400	10
15	350	400	10
16	350	400	13
17	350	400	13
18	350	400	13
19	350	400	13
20	350	400	13
21	350	400	13
22	350	400	13
23	350	400	13
24	350	400	13
25	350	400	13
26	350	400	13

### Metric Sizes, mm

Size	Length Flute	Length Overall	Diameter Shank
6	350	600	6
7	350	600	7
8	350	600	8
9	350	600	9
10	350	600	10
11	350	600	10
12	350	600	10
13	350	600	10
14	350	600	10
15	350	600	10
16	350	600	13
17	350	600	13
18	350	600	13
19	350	600	13
20	350	600	13
21	350	600	13
22	350	600	13
23	350	600	13
24	350	600	13
25	350	600	13
26	350	600	13

### Inch Sizes

Size	Length Flute	Length Overall	Diameter Shank
1/4"	8"	12"	1/4"
5/16"	8"	12"	1/4"
3/8"	8"	12"	3/8"
7/16"	8"	12"	3/8"
1/2"	8"	12"	3/8"
9/16"	8"	12"	3/8"
5/8"	8"	12"	3/8"
3/4"	8"	12"	1/2"
7/8"	8"	12"	1/2"
1"	8"	12"	1/2"

Size	Length Flute	Length Overall	Diameter Shank
1/4"	8"	18"	1/4"
5/16"	8"	18"	1/4"
3/8"	8"	18"	3/8"
7/16"	8"	18"	3/8"
1/2"	8"	18"	3/8"
9/16"	8"	18"	3/8"
5/8"	8"	18"	3/8"
3/4"	8"	18"	1/2"
7/8"	8"	18"	1/2"
1"	8"	18"	1/2"

## STCDY095, HAMMER DRILL, SDS-Plus Shank



Size	Overall Length	Size	Overall Length	Size	Overall Length	Size	Overall Length	Size	Overall Length	Size	Overall Length
5	110	8	210	12	160	14	160	18	200	20	350
5	160	8	260	12	210	14	210	18	260	20	450
5.5	110	9	160	12	260	14	260	18	300	22	260
5.5	160	9	210	12	310	14	310	18	350	22	350
6	110	10	110	12	350	14	350	18	450	22	450
6	160	10	160	12	450	14	450	19	200	24	260
6.5	110	10	210	13	160	16	160	19	260	24	450
6.5	160	10	260	13	260	16	210	19	300	25	260
7	110	10	310	13	260	16	260	19	450	25	350
7	160	10	350	13	310	16	310	20	200	25	450
8	110	11	160	13	350	16	350	20	260	26	260
8	160	11	210	13	450	16	450	20	300	26	450

## STCDY199, HAMMER DRILL, SDS-Max Shank



Size	Overall Length	Size	Overall Length	Size	Overall Length	Size	Overall Length	Size	Overall Length	Size	Overall Length
10	280	16	400	18	505	22	280	25	400	30	505
12	280	16	505	20	280	22	400	25	505	32	505
14	280	18	280	20	400	22	505	28	400	35	505
16	280	18	400	20	505	25	280	28	505	38	505

## STCDY200, HAMMER DRILL, Hex Shank



Metric Sizes, mm			Inch Sizes								
Size	Overall Length	Size	Overall Length	Size	Overall Length	Size	Overall Length	Size	Overall Length		
12	400	22	400	30	505	1/2"	12"	7/8"	12"	1-1/4"	16"
13	400	23	505	30	680	1/2"	16"	7/8"	16"	1-1/4"	22"
14	400	24	400	32	400	1/2"	22"	7/8"	22"	1-1/4"	36"
16	400	25	505	32	505	5/8"	12"	7/8"	36"	1-3/8"	16"
18	400	25	680	35	400	5/8"	16"	1"	12"	1-3/8"	22"
18	505	26	400	35	505	5/8"	22"	1"	16"	1-3/8"	36"
19	505	26	505	38	400	5/8"	36"	1"	22"	1-1/2"	16"
20	400	26	700	38	505	3/4"	12"	1"	36"	1-1/2"	22"
20	505	28	400			3/4"	16"	1-1/8"	16"	1-1/2"	36"
						3/4"	22"	1-1/8"	22"		
						3/4"	36"	1-1/8"	36"		

## STCDY201, HAMMER DRILL, Spline Shank.



Size	Overall Length	Size	Overall Length	Size	Overall Length	Size	Overall Length	Size	Overall Length	Size	Overall Length
10	280	16	400	18	505	22	280	25	400	30	505
12	280	16	505	20	280	22	400	25	505	32	505
14	280	18	280	20	400	22	505	28	400	35	505
16	280	18	400	20	505	25	280	28	505	38	505

## STCDY097, CARBIDE TIPPED CORE DRILL.

Metric Sizes		
30	65	100
35	70	105
40	75	110
45	80	115
50	85	120
55	90	125
60	95	150

Inch Sizes		
1-1/8"	1-3/4"	4"
1-1/4"	2"	4-1/2"
1-3/8"	2-1/2"	5"
1-1/2"	3"	6"
1-5/8"	3-1/2"	

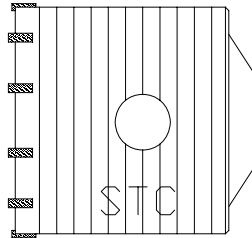

## STCDY097B, CARBIDE TIPPED CORE DRILL ACCESSORY

Hex Shank Arbor, Length: 90, 100, 110, 120, 300

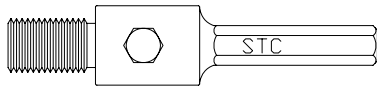

SDS-Plus Shank Arbor, Length: 110, 160, 200, 250, 300, 350, 400, 450, 500, 600mm

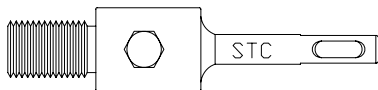

Carbide Tipped Pilot Drill.



## STCDY202, 2PCS/SET CARBIDE TIPPED CORE DRILLS

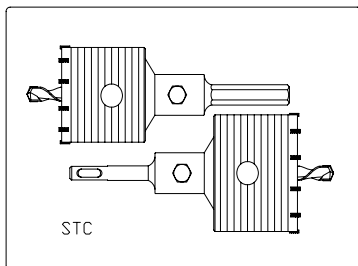

Note: Each set include 1pc each of hole saw: 65mm and 80mm. with two Arbor: Hex shank and SDS-plus shank ( interchangeable) in foam box packing with colour sleeve.

## STCDY099, CHISELS



STCDY099-1: 250mm Pointed Chisel with SDS-Plus Shank

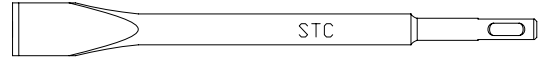

STCDY099-2: 20x295mm Small Flat Chisel with SDS-Plus Shank



STCDY099-3: 40x250mm Big Flat Chisel with SDS-Plus Shank

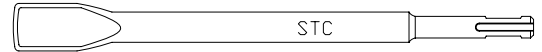

STCDY099-4: 250mm Groove Chisel with SDS-Plus Shank



STCDY099-5: Mortar Chisel with SDS-Plus Shank

## STCDY205, 4PCS SDS-PLUS CHISEL SET

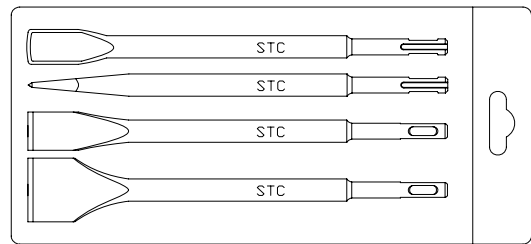

Each set Include, Flat Chisel: 22x250, 40x250mm. pointed chisel: 250mm Length, Groove chisel: 250mm. Packing: plastic bag.

## STCDY206, 12PCS/SET SDS-PLUS DRILL & CHISEL SET

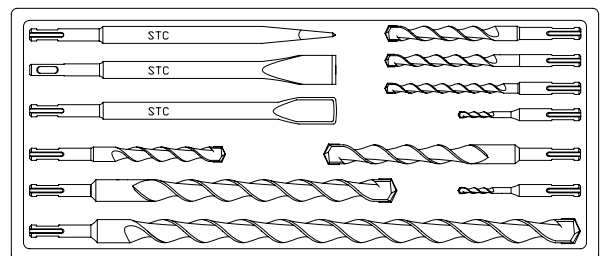

Each set include:

SDS-Plus Drill: 5x110, 6x110, 8x160 10x160  
12x160 14x200 16x210 18x300 20x450

SDS-Plus Point chisel: 250mm

SDS-Plus Flat Chisel: 22x250mm.

SDS-Plus Groove chisel: 250mm.

Package: Wood case / Blow case.

## STCDY060-1, CARBIDE TIPPED HOLE SAW

For Stainless steel & Aluminum  
Shank diameter: 10mm.  
Pilot drill: 6mm.

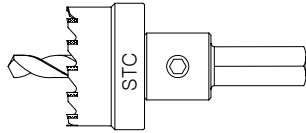

Sizes ( Metric )					
15	26	37	48	59	70
16	27	38	49	60	75
17	28	39	50	61	80
18	29	40	52	62	85
19	30	41	52	63	90
20	31	42	53	64	95
21	32	43	54	65	100
22	33	44	55	66	
23	34	45	56	67	
24	35	46	57	68	
25	36	47	58	69	

Sizes ( Inch )					
5/8"	15/16"	1-1/2"	2-1/8"	2-3/4"	3-1/2"
11/16"	1"	1-5/8"	2-1/4"	3"	3-5/8"
3/4"	1-1/8"	1-3/4"	2-3/8"	3-1/8"	3-3/4"
13/16"	1-1/4"	1-7/8"	2-1/2"	3-1/4"	4"
7/8"	1-3/8"	2"	2-5/8"	3-3/8"	

## STC268, HSS HOLE SAW

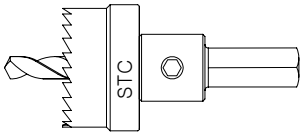

Sizes ( metric )					
12	23	34	45	56	67
13	24	35	46	57	68
14	25	36	47	58	69
15	26	37	48	59	70
16	27	38	49	60	75
17	28	39	50	61	80
18	29	40	52	62	85
19	30	41	52	63	90
20	31	42	53	64	95
21	32	43	54	65	100
22	33	44	55	66	

Sizes ( Inch )					
1/2"	13/16"	1-1/4"	1-7/8"	2-1/2"	3-1/4"
9/16"	7/8"	1-3/8"	2"	2-5/8"	3-1/2"
5/8"	15/16"	1-1/2"	2-1/8"	2-3/4"	3-3/4"
11/16"	1"	1-5/8"	2-1/4"	2-7/8"	4"
3/4"	1-1/8"	1-3/4"	2-3/8"	3"	

Fully Ground HSS hole saw also available.

## STC268AS, HSS HOLE SAW SET

8pcs	16, 20, 22, 25, 28, 30, 32, 35mm
8pcs	18, 20, 22, 25, 30, 32,35, 40mm
5pcs	18, 20, 22, 25, 30mm
8pcs	5/8", 3/4", 7/8", 1", 1-1/8", 1-1/4", 1-3/8", 1-1/2"

packed in wooden case.

## STCDY054, BI-METAL HOLE SAW

M3 Bi-Metal Material.  
1-3/8" (35mm) depth of cut.  
Variable tooth design

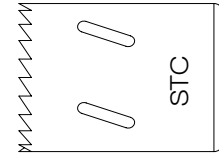

Diameter		Diameter		Diameter	
Metric	Inch	Metric	Inch	Metric	Inch
14	9/16"	41	1-5/8"	79	3-1/8"
16	5/8"	43	1-11/16"	83	3-1/4"
17	11/16"	44	1-3/4"	86	3-3/8"
19	3/4"	46	1-13/16"	89	3-1/2"
20	25/32"	48	1-7/8"	92	3-5/8"
21	13/16"	51	2"	95	3-3/4"
22	7/8"	52	2-1/16"	98	3-7/8"
24	15/16"	54	2-1/8"	102	4"
25	1"	57	2-1/4"	105	4-1/8"
27	1-1/16"	59	2-5/16"	108	4-1/4"
29	1-1/8"	60	2-3/8"	111	4-3/8"
30	1-3/16"	64	2-1/2"	114	4-1/2"
32	1-1/4"	65	2-9/16"	121	4-3/4"
33	1-5/16"	67	2-5/8"	127	5"
35	1-3/8"	68	2-11/16"	133	5-1/4"
37	1-7/16"	70	2-3/4"	140	5-1/2"
38	1-1/2"	73	2-7/8"	146	5-3/4"
40	1-9/16"	76	3"	152	6"

## STCDY054L, DEEP CUT BI-METAL HOLE SAW

cutting depth up to 1-7/8"(47mm)  
Size available: Ø9/16" - 6"

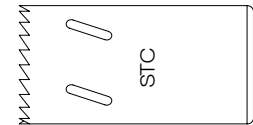

## STCDY057: BI-METAL HOLE SAW KITS

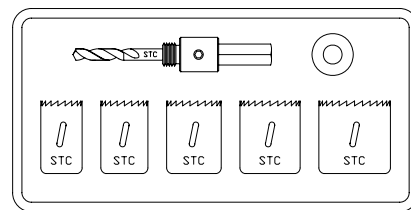

7pcs/set mechanics' kit - 1ea. 7/8", 1", 1-1/8", 1-1/4", 1-1/2". 1pc arbor, 1pc screw.
9pcs/set electrician's kit -ea. 7/8", 1-1/8", 1-3/8", 1-3/4", 2", 2-1/2" 2pcs arbor, 1pc screw.
9pcs/set Plumber's kits - 1ea. 3/4", 7/8", 1-1/8", 1-1/2", 1-3/4", 2-1/4" 2pcs arbor, 1pc screw.
13pcs/set journeyman,s kits - ea. 3/4", 7/8", 1-1/8", 1-3/8", 1-1/2", 1-3/4", 2", 2-1/4", 2-1/2". 2pcs arbors, 1pcs screw, 1pc pilot drill 1/4"x4".
15pcs/set industrial kits - ea. 3/4", 7/8", 1", 1-1/4", 1-3/8", 1-1/2", 1-3/4", 2", 2-1/4", 2-1/2", 3". 2pcs arbors, 1pc extension bar, 1pc ejector spring.
17pcs/set: hole saw-ea: 19mm, 20mm, 22mm, 25mm, 29mm, 32mm, 35mm, 38mm, 44mm, 51mm, 57mm, 67mm, 76mm. 2pcs arbors, 1pc pilot drill, 1pc 12" extension rod.

## STCDY055, Bi-METAL HOLE SAW ARBOR & ACCESSORIES

ILLUSTRATION	ORDER NO.	SHANK SIZE	CHUCK SIZE	THREAD SIZES	APPLICATION
	STCDY055-1	1/4" Round	1/4"	1/2"-20 UNF	9/16" - 1.3/16"
	STCDY055-2	3/8" Hex	3/8"	1/2"-20 UNF	9/16" - 1.3/16"
	STCDY055-3	7/16" Hex	1/2"	1/2"-20 UNF	9/16" - 1.3/16"
	STCDY055-4	7/16" Hex	1/2"	5/8"-18 UNF	1.3/4" - 3"
	STCDY055-5	7/16" Hex	1/2"	5/8"-18 UNF Quick change	1.1/4" - 6"
	STCDY055-6	3/8"	3/8"	5/8"-18 UNF	1.1/4" - 6"
	STCDY055-7	7/16" Hex	1/2"	5/8"-18 UNF	1.1/4" - 6"
	STCDY055-8	5/8"	3/4"	5/8"-18 UNF	1.1/4" - 6"
	STCDY055-9	Quick change 1/4" Hex	Quick chang Chuck 1/4"	1/2"-20 UNF	9/16" - 1.3/16"
	STCDY055-10	Quick change 1/4" Hex	Quick chang Chuck 1/4"	5/8"-18 UNF	1.3/4" - 3"
	STCDY055-11	SDS-Plus		1/2"-20 UNF	9/16" - 1.3/16"
	STCDY055-12	SDS-Plus		5/8"-18 UNF	1.1/4" -- 6"
	STCDY055-14	1/4" X 3" HSS Pilot Drill Fit Arbor			
	STCDY055-15	1/4" X 4" HSS Pilot Drill Fit Arbor			
	STCDY055-16-1	Extension Shank: 5-1/2" ( 140mm)			
	STCDY055-16-2	Extension Shank: 10" ( 250mm)			
	STCDY055-16-3	Extension Shank: 12" (300mm)			
	STCDY055-16-4	Extension Shank: 18" (450mm)			
<p>Adapter Arbors ( screw ) 1/2"-20UNF thread to Hole saw 5/8"-18UNF</p>	STCDY055-17	<p>Ejected Spring STCDY055-18</p>	<p>Hex Wrench STCDY055-19</p>		

## STCDY155, CARBIDE TIPPED GLASS DRILL

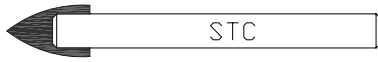

Size	Total Length
3	55
4	55
5	55
6	65
6.5	65
8	75
10	90
12	90
13	90

Size	Total Length
1/8"	2-3/16"
5/32"	2-3/16"
3/16"	2-3/16"
1/4"	2-3/16"
5/16"	2-15/16"
3/8"	3-9/16"
7/16"	3-9/16"
1/2"	3-9/16"

## STCDY155S, GLASS DRILL SET

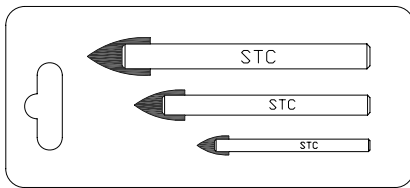

ORDER NO.	Pcs/set	Description		
STC155S-1	3pcs	3mm	6mm	8mm
STC155S-2	5pcs	3mm	5mm	6mm
		8mm	10mm	
STC155S-3	5pcs	1/8"	3/16"	1/4"
		5/16"	3/8"	

## STCDY061, DIAMOND COATED HOLE SAW, for Glass

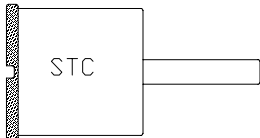

Outside Diameter					
4	15	30	55	85	130
5	18	32	60	90	140
6	20	35	65	95	150
8	22	40	70	100	160
10	25	45	75	110	
12	27	50	80	120	

## STCDY062, 3PCS DIAMOND HOLE SAW, For Glass, Marble & Tile

Specification
1/4" ( 6mm)
5/16" ( 8mm)
3/8" ( 10mm)

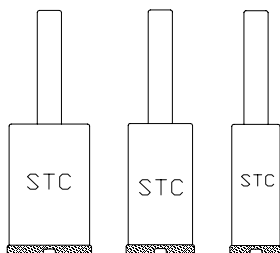

## STCDY045, 16PCS/SET CARBON STEEL HOLE SAW SET

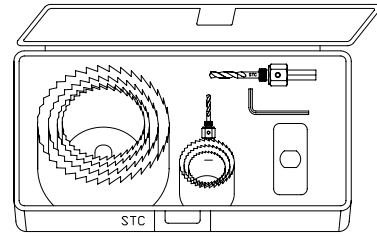

Each include 14pcs CS hole saw: 3/4", 7/8", 1-1/8", 1-1/4", 1-1/2", 1-3/4", 2", 2-1/2", 3", 3-1/2", 4", 5"  
2pcs arbors, 1pcs reinforce metal plate, 1pcs hex wrench.

## STCDY046, 2PCS/SET LOCKING INSTALLATION KIT

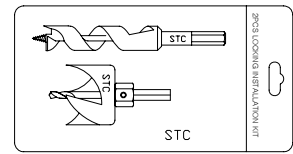

1pc CS hole saw: 2-1/2".  
1pc auger bits: 7/8"  
in blister card packing.

## STCDY047, 3PCS/SET LOCKING INSTALLATION KIT

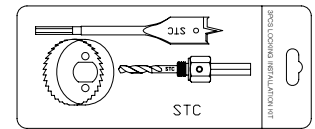

1pcs CS hole saw: 2-1/8"  
1pcs wood spade drill: 7/8".  
1pcs CS hole saw arbor.

## STCDY048, 11PCS/SET CARBON STEEL HOLE SAW SET

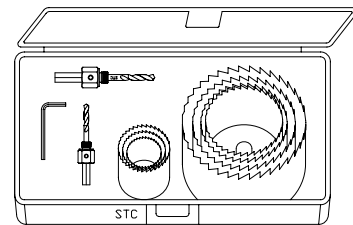

Each include:  
8pcs CS hole saw: 3/4", 7/8", 1-1/8", 1-3/8", 1-1/2", 1-3/4", 2", 2-1/2".  
2pcs arobrs, 1pc hex wrench.

## STCDY048, 7PCS/SET CARBON STEEL HOLE SAW SET

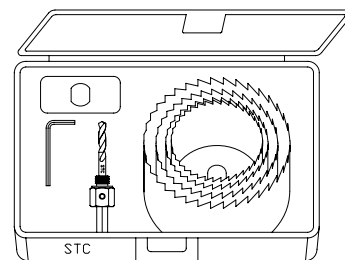

Each include 4pcs Carbon Steel hole saw: 3", 3-1/2", 4", 5"  
1pc Hex wrench, 1pc arbor, 1pc reinforce steel plate.

## STCDY311, BRAD POINT DRILL



Size	overall Length	Size	overall Length	Size	overall Length
3	60	20	160	10	250
4	75	21	160	4	300
5	85	22	160	5	300
6	90	23	160	6	300
7	105	24	160	7	300
8	115	25	160	8	300
9	120	26	160	9	300
10	120	28	160	10	300
11	150			12	300
12	150	6	200	13	300
13	150	8	200	14	300
14	150	10	200		
15	150	12	200	6	400
16	160			8	400
18	160	6	250	10	400
19	160	8	250	12	400

Overall Length 600mm also available on request.

Inch Sizes, Special Sizes also available on request.

Size	overall Length	Size	overall Length	Size	overall Length
1/8"	2-3/8"	3/8"	4-3/4"	3/4"	6-3/8"
5/32"	3"	7/16"	6"	13/16"	6-3/8"
3/16"	3-3/8"	15/32"	6"	7/8"	6-3/8"
1/4"	3-5/8"	1/2"	6"	15/16"	6-3/8"
9/32"	4"	9/16"	6"	1"	6-3/8"
5/16"	4-3/8"	5/8"	6-3/8"	1-1/8"	6-3/8"
11/32"	4-3/4"	11/16"	6-3/8"	1-1/4"	6-3/8"

## STCDY321, WOOD SPADE DRILL

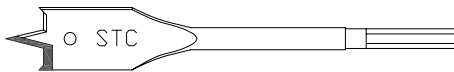

Size	Overall Length	Size	Overall Length
6	152	20	152
8	152	22	152
10	152	24	152
11	152	25	152
12	152	26	152
13	152	28	152
14	152	30	152
15	152	32	152
16	152	35	152
17	152	38	152
18	152	40	152
19	152	305	305

metric

Size	Overall Length	Size	Overall Length
1/4"	6"	3/4"	6"
5/16"	6"	15/16"	6"
3/8"	6"	7/8"	6"
7/16"	6"	1"	6"
1/2"	6"	1-1/8"	6"
9/16"	6"	1-1/4"	6"
5/8"	6"	1-3/8"	6"
11/16"	6"	1-1/2"	6"

Inch

## STCDY331, WOOD AUGER BITS



Size	Overall Length	Size	Overall Length
6	230	21	230
8	230	22	230
10	230	23	230
11	230	24	230
12	230	25	230
13	230	26	230
14	230	28	230
15	230	30	230
16	230	32	230
17	230	35	230
18	230	38	230
19	230	40	230
20	230	460	460

Size	Overall Length	Size	Overall Length
1/4"	9"	18"	13/16"
5/16"	9"	18"	7/8"
3/8"	9"	18"	15/16"
7/16"	9"	18"	1"
1/2"	9"	18"	1-1/8"
9/16"	9"	18"	1-1/4"
5/8"	9"	18"	1-3/8"
11/16"	9"	18"	1-1/2"
3/4"	9"	18"	

## STCDY341, FORSTNER BITS

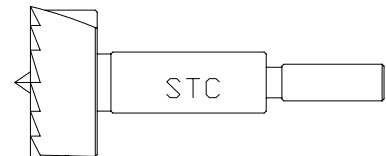

Length: 90mm

Size	shank	Size	shank	Size	shank
6	6	20	8	35	10
8	6	22	8	36	10
10	8	24	8	38	10
11	8	25	8	40	10
12	8	26	8	42	10
14	8	28	8	45	10
15	8	30	8	50	10
16	8	32	10	55	10
18	8	34	10		

Size	overall Length	Size	overall Length	Size	overall Length
1/4"	3-5/32"	1-3/4"	3-5/32"	3-1/4"	6-1/4"
3/8"	3-5/32"	1-7/8"	3-5/32"	3-3/8"	6-1/4"
1/2"	3-5/32"	2"	3-5/32"	3-1/2"	6-1/4"
5/8"	3-5/32"	2-1/8"	3-5/32"	3-5/8"	6-1/4"
3/4"	3-5/32"	2-1/4"	6-1/4"	3-3/4"	6-1/4"
7/8"	3-5/32"	2-3/8"	6-1/4"	3-7/8"	6-1/4"
1"	3-5/32"	2-1/2"	6-1/4"	4"	6-1/4"
1-1/8"	3-5/32"	2-5/8"	6-1/4"	4-1/8"	6-1/4"
1-1/4"	3-5/32"	2-3/4"	6-1/4"	4-1/4"	6-1/4"
1-3/8"	3-5/32"	2-7/8"	6-1/4"	4-3/8"	6-1/4"
1-1/2"	3-5/32"	3"	6-1/4"	4-1/2"	6-1/4"
1-5/8"	3-5/32"	3-1/8"	6-1/4"		

## STCDY063, JIG SAW BLADE



overall length	T.P.I	Material	Teeth	Fitting Shaft	
75	3"	24	HSS	Fine	Bosch, Aeg, Peugeot
75	3"	14	HSS	Medium	Bosch, Aeg, Peugeot
75	3"	10	HSS	Coarse	Bosch, Aeg, Peugeot
75	3"	24	Bi-metal	Fine	Bosch, Aeg, Peugeot
75	3"	14	Bi-metal	Medium	Bosch, Aeg, Peugeot
75	3"	10	Bi-metal	Coarse	Bosch, Aeg, Peugeot
75	3"	24	HCS	Fine	Bosch, Aeg, Peugeot
75	3"	14	HCS	Medium	Bosch, Aeg, Peugeot
75	3"	10	HCS	Coarse	Bosch, Aeg, Peugeot
100	4"	8	HCS	Medium	Bosch, Aeg, Peugeot
100	4"	6	HCS	Coarse	Bosch, Aeg, Peugeot
100	4"	8	Alloy	Medium	Bosch, Aeg, Peugeot
100	4"	6	Alloy	Coarse	Bosch, Aeg, Peugeot
100	4"	8	HCS	Medium	Bosch, Aeg, Peugeot
100	4"	6	HCS	Coarse	Bosch, Aeg, Peugeot
70	2-3/4"	24	HSS	Fine	B&D, Skill, Ryobi
70	2-3/4"	18	HSS	Medium	B&D, Skill, Ryobi
75	3"	14	HSS	Coarse	B&D, Skill, Ryobi
70	2-3/4"	24	Bi-metal	Fine	B&D, Skill, Ryobi
70	2-3/4"	18	Bi-metal	Medium	B&D, Skill, Ryobi
75	3"	14	Bi-metal	Coarse	B&D, Skill, Ryobi
70	2-3/4"	24	HCS	Fine	B&D, Skill, Ryobi
70	2-3/4"	18	HCS	Medium	B&D, Skill, Ryobi
75	3"	14	HCS	Coarse	B&D, Skill, Ryobi
89	3-1/2"	10	HSS	Fine	B&D, Skill, Ryobi
89	3-1/2"	8	HSS	Medium	B&D, Skill, Ryobi
89	3-1/2"	6	HSS	Coarse	B&D, Skill, Ryobi
75	3"	24	HSS	Fine	B&D, Skill, Ryobi
75	3"	14	HSS	Medium	B&D, Skill, Ryobi

overall length	T.P.I	Material	Teeth	Fitting Shaft	
75	3"	10	HSS	Coarse	B&D, Skill, Ryobi
75	3"	24	Bi-metal	Fine	B&D, Skill, Ryobi
75	3"	14	Bi-metal	Medium	B&D, Skill, Ryobi
75	3"	10	Bi-metal	Coarse	B&D, Skill, Ryobi
87	3-3/8"	14	Alloy	Fine	B&D, Skill, Ryobi
87	3-3/8"	10	Alloy	Medium	B&D, Skill, Ryobi
87	3-3/8"	6	Alloy	Coarse	B&D, Skill, Ryobi
85	3-11/32"	24	HSS	Fine	Makita
85	3-11/32"	18	HSS	Medium	Makita
85	3-11/32"	9	HSS	Coarse	Makita
82	3-7/32"	24	HSS	Fine	Makita
82	3-7/32"	14	HSS	Medium	Makita
82	3-7/32"	9	HSS	Coarse	Makita
97	3-3/4"	24	Alloy	Fine	Peugeot
97	3-3/4"	14	Alloy	Medium	Peugeot
97	3-3/4"	6	Alloy	Coarse	Peugeot
75	3"	24	HSS	Fine	B&D, Skill, Ryobi
75	3"	18	HSS	Medium	B&D, Skill, Ryobi
87	3-3/8"	7	HSS	Coarse	B&D, Skill, Ryobi
87	3-3/8"	6	HSS	Coarse	B&D, Skill, Ryobi
75	3"	7	HSS	Curve	B&D, Skill, Bosch
70	2-3/4"	14	HSS	Curve	B&D, Skill, Bosch
75	3"	14	HSS	Curve	B&D, Skill, Bosch
75	3"	12	HSS	Curve	B&D, Skill, Bosch
75	3"	7	HSS	T.Caribde	B&D, Skill, Bosch
70	2-3/4"	14	HSS	T.Caribde	B&D, Skill, Bosch
75	3"	14	HSS	T.Caribde	B&D, Skill, Bosch
75	3"	12	HSS	T.Caribde	B&D, Skill, Bosch

## STCDY156, BI-METAL RECIPROCATING SAW BLADE, (1/2" Shank)

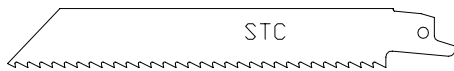

Inch Size	Metric Size	T.P.I	Teeth	Cutting
4x3/4x0.035"	100x20x0.9mm	14	straight	wood & metal
4x3/4x0.035"	100x20x0.9mm	18	straight	wood & metal
4x3/4x0.035"	100x20x0.9mm	24	straight	metal
6x3/4x0.05"	150x20x1.3mm	6	tapered	wood with nail
6x3/4x0.035	150x20x0.9mm	6	tapered	wood with nail
6x3/4x0.035	150x20x0.9mm	6	tapered	wood with nail
6x3/4x0.035	150x20x0.9mm	10/14	straight	wood & metal
6x3/4x0.035	150x20x0.9mm	10/14	straight	wood & metal
6x3/4x0.035	150x20x0.9mm	14	straight	metal
6x3/4x0.035	150x20x0.9mm	18	straight	metal
6x3/4x0.035	150x20x0.9mm	24	straight	metal
8"x3/4x0.035	200x20x0.9mm	10/14	straight	wood w/nail & metal
8x3/4x0.050"	200x20x1.3mm	10/14	straight	metal
8x3/4x0.035"	200x20x0.9mm	14	straight	wood & metal
8x3/4x0.035"	200x20x0.9mm	18	straight	metal
12x3/4x0.035"	300x20x0.9mm	6	tapered	wood with nail
12x3/4x0.05"	300x20x1.3mm	6	tapered	wood with nail
12x3/4x0.035"	300x20x0.9mm	10/14	tapered	wood with nail
12x3/4x0.05"	300x20x1.3mm	10/14	tapered	wood with nail
12x3/4x0.035"	300x20x0.9mm	14	straight	metal
12x3/4x0.035"	300x20x0.9mm	18	straight	metal

## STCDY065-1, HAND HACK SAW BLADE

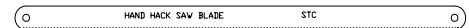

Length x Width x Thickness	T.P.I
10"x1/2"x0.025" (250x13x0.65mm)	18,24,32
12"x1/2"x0.025" (300x13x0.65mm)	14,18,24,32

Material: HCS, HSS, Bi-Metal.

## STCDY065-2, POWER HACK SAW BLADE

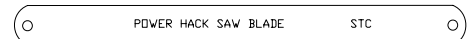

Length x Width x Thickness	T.P.I
12"x 1" x0.05" (300x25x1.25mm)	10, 14
14" x 1" x 0.05" (350x25x1.25mm)	10, 14
14"x1-1/4"x0.063" (350x32x1.6mm)	6, 10
16"x1-1/4"x0.063" (400x32x1.6mm)	6, 10
16"x1-1/2"x0.071" (400x38x1.8mm)	4, 6
16"x1-9/16"x0.079" (400x40x2.0mm)	4, 6
18"x1-1/4"x0.063" (450x32x1.6mm)	6, 10
18"x1-1/2"x0.071" (450x38x1.8mm)	4, 6
18"x1-9/16"x0.079" (450x40x2.0mm)	4, 6
20"x1-9/16"x0.079" (500x40x2.0mm)	4, 6, 10
24"x2"x0.10" (600x50x2.5mm)	4, 6

Material: HSS, Bi-metal.

## STEEL FILES

MATERIAL: T12,

STANDARD AVAILABLE: GOST1465-80, QB/T2569.1-2002, AMERICAN PATTERN, SWISS PATTERN.

### STCSF0100A, STEEL FILES, Flat

Cut: Bastard, Second, Smooth ( Coarse, Medium, Fine )



Length	Inch	4", 5", 6", 8", 10", 12", 14", 16", 18"
	mm	100, 125, 150, 200, 250, 300, 350, 400, 450mm

### STCSF0100B, STEEL FILES, Flat - Point

Cut: Bastard, Second, Smooth ( Coarse, Medium, Fine )



Length	Inch	4", 5", 6", 8", 10", 12", 14", 16", 18"
	mm	100, 125, 150, 200, 250, 300, 350, 400, 450mm

### STCSF0200, STEEL FILES, Triangular

Cut: Bastard, Second, Smooth ( Coarse, Medium, Fine )



Length	Inch	4", 5", 6", 8", 10", 12", 14", 16", 18"
	mm	100, 125, 150, 200, 250, 300, 350, 400, 450mm

### STCSF0300, STEEL FILES, Half - round

Cut: Bastard, Second, Smooth ( Coarse, Medium, Fine )



Length	Inch	4", 5", 6", 8", 10", 12", 14", 16", 18"
	mm	100, 125, 150, 200, 250, 300, 350, 400, 450mm

### STCSF0400, STEEL FILES, Round

Cut: Bastard, Second, Smooth ( Coarse, Medium, Fine )



Length	Inch	4", 5", 6", 8", 10", 12", 14", 16", 18"
	mm	100, 125, 150, 200, 250, 300, 350, 400, 450mm

### STCSF0500, STEEL FILES, Square

Cut: Bastard, Second, Smooth ( Coarse, Medium, Fine )



Length	Inch	4", 5", 6", 8", 10", 12", 14", 16", 18"
	mm	100, 125, 150, 200, 250, 300, 350, 400, 450mm

### STCSF0600, STEEL FILES, Feather Edge

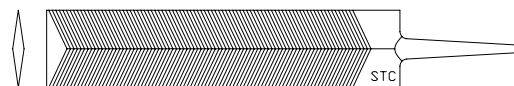

Length	Inch	3", 3.5", 4", 5", 6", 8", 10"
	mm	75, 90, 100, 125, 150, 200, 250mm

### STCSF0700, MILL FILES



Length	Inch	6", 8", 10", 12", 14"
	mm	150, 200, 250, 300, 350mm

### STCSF0800, MILL SAW, Round Edge



Length	Inch	6", 8", 10", 12", 14"
	mm	150, 200, 250, 300, 350mm

### STCSF1000, HALF ROUND CURVED TEETH FILES

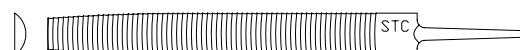

Length	Inch	6", 8", 10", 12", 14"
	mm	150, 200, 250, 300, 350mm

### STCSF1100, CURVED TEETH FILES



Length	Inch	8", 10", 12", 14", 16", 18"
	mm	200, 250, 300, 350, 400, 450mm

### STCSF1200, DOUBLE HOLE CURVED TEETH FILE



Length	14" / 350mm	
Teeth per Inch	6, 7, 8, 9, 10, 11, 12	

### STCSF1300, FARMER'S OWN FILES



Length	Inch	8", 10", 12"
	mm	200, 250, 300mm

## STCSF1400, SLIM TAPER FILES



Length	Inch	3", 4", 5", 6", 7", 8"
	mm	75, 100, 125, 150, 175, 200mm

## STCSF2100, FLAT WOOD RASP



Length	Inch	6", 8", 10", 12"
	mm	150, 200, 250, 300mm

## STCSF1500, EXTRA SLIM TAPER FILES



Length	Inch	3", 4", 5", 6", 7", 8"
	mm	75, 100, 125, 150, 175, 200mm

## STCSF2200, ROUND WOOD RASP



Length	Inch	6", 8", 10", 12"
	mm	150, 200, 250, 300mm

## STCSF1600, HEAVY TAPER FILES



Length	Inch	4", 5", 6", 7", 8"
	mm	100, 125, 150, 175, 200mm

## STCSF2300, HALF ROUND WOOD RASP



Length	Inch	6", 8", 10", 12"
	mm	150, 200, 250, 300mm

## STCSF1700, BAND SAW BLUNT FILES



Length	Inch	4", 5", 6", 7", 8"
	mm	100, 125, 150, 175, 200mm

## STCSF2400, HALF ROUND CARPENTER'S FILES



Length:	8" / 200mm
---------	------------

## STCSF1800, DOUBLE END FILES



Length	Inch	4", 5", 6", 7", 8"
	mm	100, 125, 150, 175, 200mm

## STCSF2500, KNIFE FILES



Length	Inch	8", 10", 12", 14"
	mm	200, 250, 300, 350mm

## STCSF1900, HALF ROUND WOOD RASP



Length	Inch	6", 8", 10", 12"
	mm	150, 200, 250, 300mm

## STCSF2600, CHAIN SAW FILES



Length	Inch	6", 6", 8", 8", 8", 8", 10", 10", 10", 12"
	mm	150, 150, 200, 200, 200, 200, 250, 250, 250, 300mm
Diameter		3.6, 4.8, 4.0 4.5, 4.8, 5.5 4.0, 4.8, 5.5, 5.5mm

## STCSF2000, FLAT-POINT WOOD RASP



Length	Inch	6", 8", 10", 12"
	mm	150, 200, 250, 300mm

## STCSF2700, HORSE HOOF FILES



Length	Inch	12", 14", 16", 18"
	mm	300, 350, 400, 450mm

## STCSF 2900, NEEDLE FILES

MATERIAL: Alloy Steel. GCr15,

STANDARD AVAILABLE: GOST1513, QB/T2569.3-2002, AMERICAN PATTERN, SWISS PATTERN.

SPECIAL SPECIFICATIONS AVAILABLE ON REQUEST.

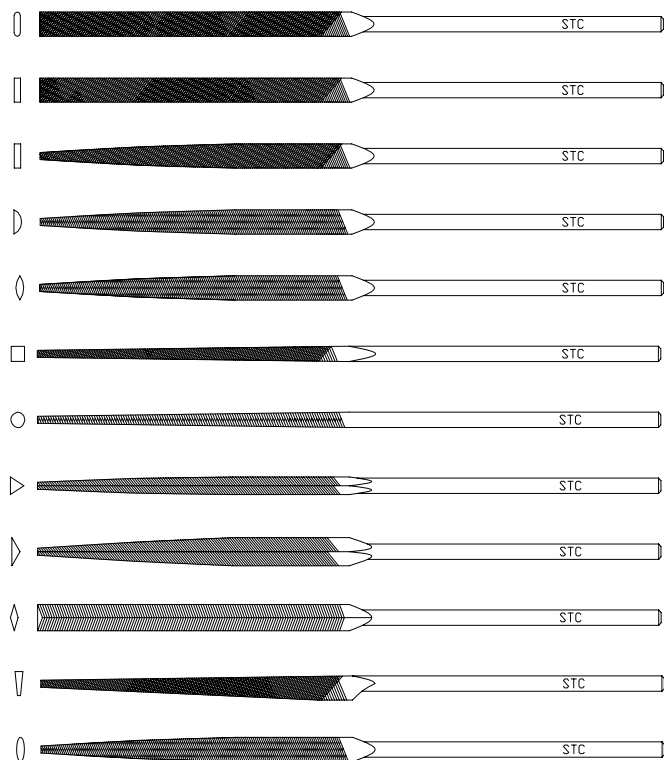

SIZE	12PCS	10PCS	8PCS	7PCS	5PCS
JointRound edge	X				
Flat	X	X	X	X	X
Flat-point	X	X	X	X	
Half Round	X	X	X	X	X
Crossing	X	X			
Square	X	X	X	X	X
Round	X	X	X	X	X
Triangular	X	X	X	X	X
Barrette	X	X	X		
Feather Edge	X				
Knife	X	X	X	X	
Ovel	X	X			

## STCSF2901, DIE SINKER RIFFLERS

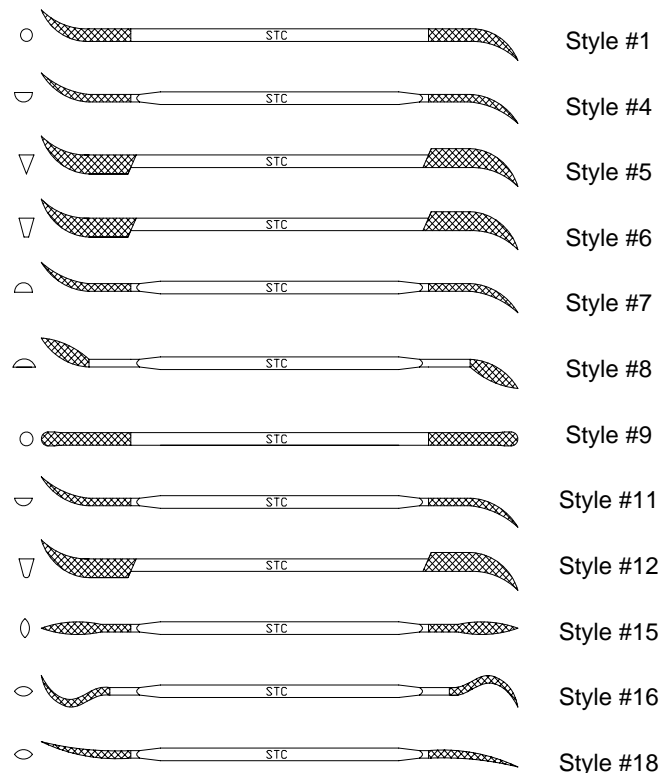

## STCSF2902, SILVERSMITH AND DIE MAKER'S RIFFLERS

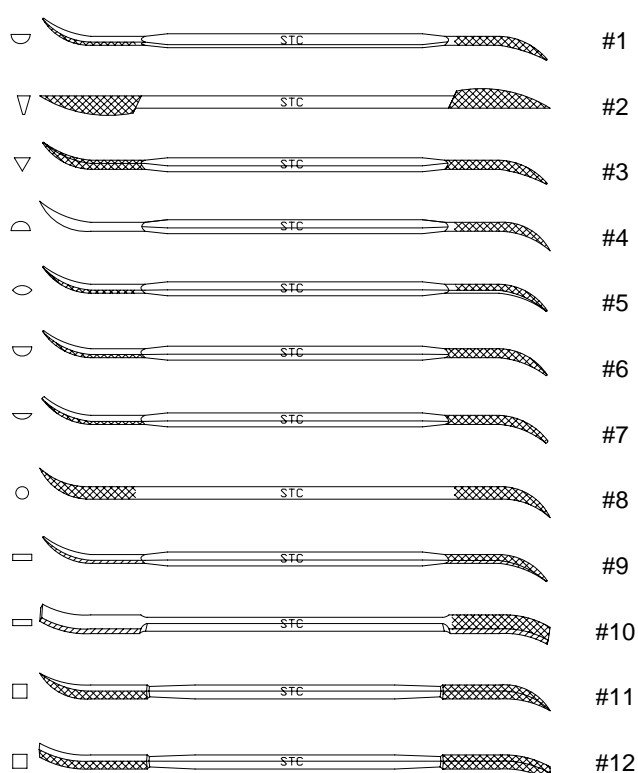

## STCSF 2800, DIAMOND NEEDLE FILES SET.

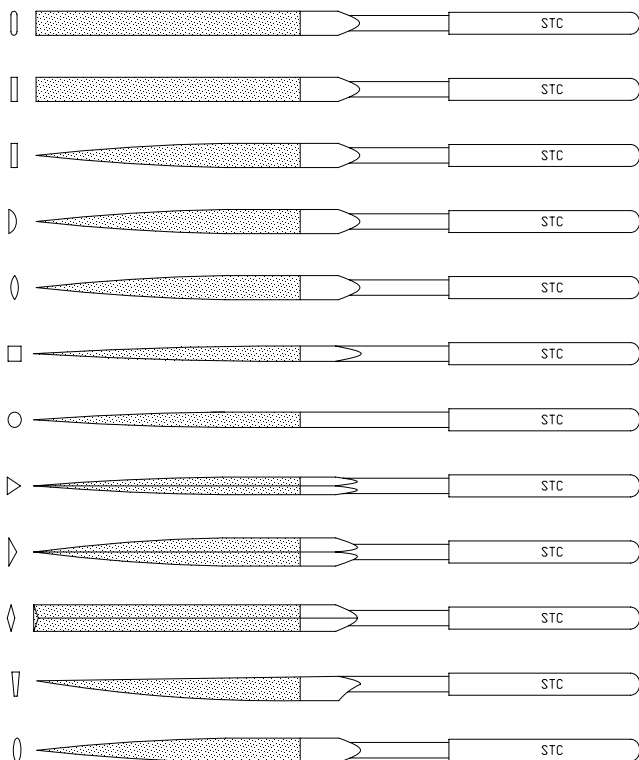

SIZE	12PCS	10PCS	8PCS	7PCS	5PCS
Joint Round edge	X				
Flat	X	X	X	X	X
Flat-point	X	X	X	X	
Half Round	X	X	X	X	X
Crossing	X	X			
Square	X	X	X	X	X
Round	X	X	X	X	X
Triangular	X	X	X	X	X
Barrette	X	X	X		
Feather Edge	X				
Knife	X	X	X	X	
Ovel	X	X			

2X100X40, 3X140X50/70, 3X160X50/70, 4X160/50/70, 4X180X50/70, 5X180X50/70, 5X200X50/70.

## STCDY087, DIEMAKER'S DIAMOND RIFFLER FILE SET

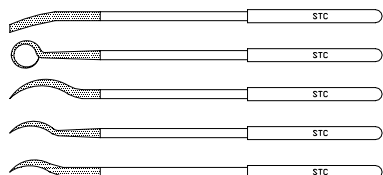

ORDER NO.	PCS / SET	DESCRIPTION (mm)
STCDY087-1	5	3X140X30
STCDY087-2	10	3X140X30

## STCDY083, DIAMOND POINTER SET

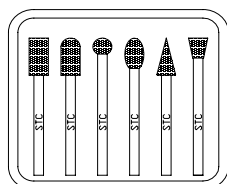

STCDY087 - 5

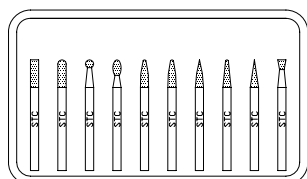

STC087 - 6

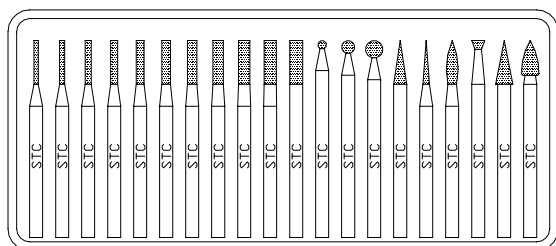

STCDY087 - 1

ORDER NO.	Shank Diameter	Overall Length	Pcs/set	Grid
STCDY087 - 1	1/8"	45	20	100 / 150
STCDY087 - 2	3/32"	45	30	100 / 150
STCDY087 - 3	1/8"	45	50	100 / 150
STCDY087 - 4	1/8", 3mm	45	50	100 / 150
STCDY087 - 5	1/4"	60	6	80
STCDY087 - 6	1/4"	60	5	50
STCDY087 - 7	1/4"	60	10	150
STCDY087 - 8	3/32"	45	10	100 / 150
STCDY087 - 9	3/32"	45	8	50 / 100 / 150
STCDY087 - 10	3mm	45	8	150
STCDY087 - 11	3mm	45	20	150
STCDY087 - 12	3mm	45	30	150
STCDY087 - 13	1/8"	45	30	100 / 150
STCDY087 - 14	6mm	45	10	150
STCDY087 - 15	6mm	60	5	150
STCDY087 - 16	6mm	60	20	150

STCDY067A, CARBIDE BURR, with 1/4" shank

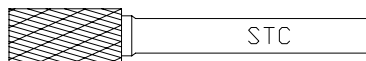

### Cylindrical Shape

Order No.	Size
SA-14	3/16"X5/8"
SA - 1	1/4"x5/8"
SA - 2	5/16"x3/4"
SA - 3	3/8"x3/4"
SA - 4	7/16"x1"
SA - 5	1/2"x1"
SA - 6	5/8"x1"
SA - 7	3/4"x1"
SA - 9	1"x1"

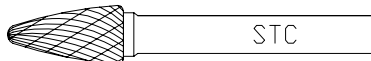

### Tree Shape Radius End

Order No.	Size
SF-1	1/4"X5/8"
SF-3	3/8"X3/4"
SF-4	7/16"X1"
SF-13	1/2"X3/4"
SF-5	1/2"X1"
SF-6	5/8"X1"
SF-7	3/4"X1"

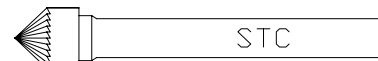

### 90° Taper Shape

Order No.	Size
SK-1	1/4"X1/8"
SK-3	3/8"X3/16"
SK-5	1/2"X1/4"
SK-6	5/8"X5/16"
SK-7	3/4"X3/8"

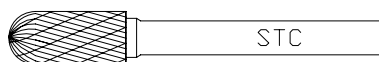

### Cylindrical Radius End

Order No.	Size
SC-14	3/16"X5/8"
SC - 1	1/4"X5/8"
SC - 2	5/16"X3/4"
SC - 3	3/8"X3/4"
SC - 4	7/16"X1"
SC - 5	1/2"X1"
SC - 6	5/8"X1"
SC - 7	3/4"X1"

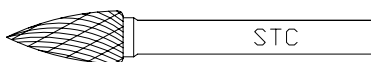

### Tree Shape Sharp End

Order No.	Size
SG-1	1/4"X5/8"
SG-2	5/16"X3/4"
SG-13	1/2"X3/4"
SG-5	1/2"X1"
SG-6	5/8"X1"
SG-7	3/4"X1"

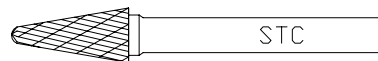

### Taper with Ball End

Order No.	Size	Taper
SL-1	1/4"X5/8"	14°
SL-2	5/16"X7/8"	14°
SL-3	3/8"X1-1/6"	14°
SL-4	1/2"X1-1/8"	14°
SL-6	5/8"X1-5/16"	14°
SL-7	3/4"X1-1/2"	14°

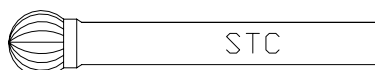

### Ball Shape

Order No.	Size
SD-11	1/8"
SD-14	3/16"
SD - 1	1/4"
SD - 2	5/16"
SD - 3	3/8"
SD - 5	1/2"
SD - 6	5/8"
SD - 7	3/4"
SD - 9	1"

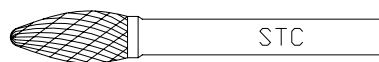

### Torch Shape

Order No.	Size
SH-1	1/4"X5/8"
SH-2	5/16"X3/4"
SH-5	1/2"X1-1/4"
SH-6	5/8"X1-7/16"
SH-7	3/4"X1-5/8"

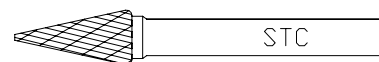

### Taper

Order No.	Size	Taper
SM-1	1/4"X1/2"	22°
SM-2	1/4"X3/4"	14°
SM-3	1/4"X1"	10°
SM-4	3/8"X5/8"	28°
SM-5	1/2"X7/8"	28°
SM-6	5/8"X1"	31°

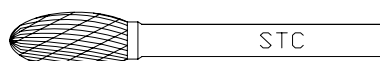

### Oval Shape

Order No.	Size
SE-1	1/4"X3/8"
SE-3	3/8"X5/8"
SE-5	1/2"X7/8"
SE-6	5/8"X1"
SE-7	3/4"X1"

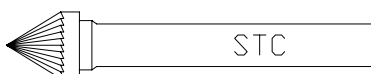

### 60° Taper Shape

Order No.	Size
SJ-1	1/4"X3/16"
SJ-3	3/8"X1/4"
SJ-5	1/2"X7/16"
SJ-6	5/8"X1/2"
SJ-7	3/4"X5/8"



### Opposite Taper

Order No.	Size	Taper
SN-1	1/4"X5/16"	10°
SN-4	1/2"X1/2"	16°
SN-6	5/8"X3/4"	18°

Inch Sizes Carbide burr with 1/8" shank also available.

Inch Sizes Carbide burr with 3/32" shank also available.

Metric Sizes Carbide burr with 6mm shank also available.

Metric Sizes Carbide burr with 3mm shank also available.

Special Specification available on request.

## STC067B, CARBIDE BURR SET

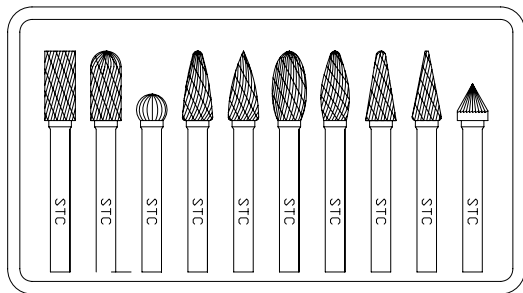

STCDY067B-2A

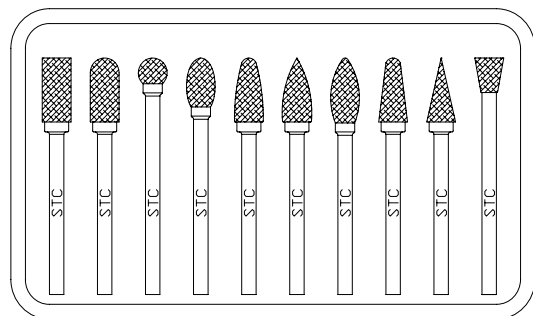

STCDY067-2

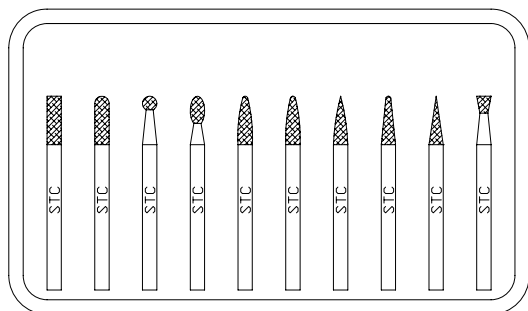

STCDY067B-3

## STCDY069-1, HSS BURR

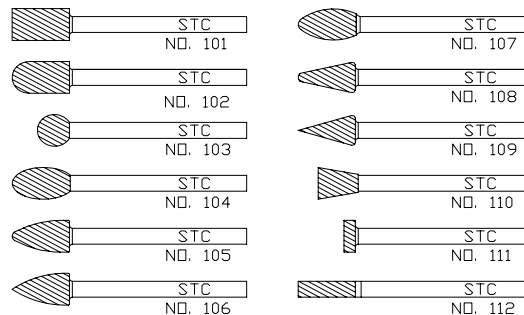

Code No.	Head Diameter	Head Length	Shank Diameter	Shank Length
NO.101	6mm	10	3mm, 1/8"	30
NO.102	6	10	3mm, 1/8"	30
NO.103	6		3mm, 1/8"	30
NO.104	6	10	3mm, 1/8"	30
NO.105	6	10	3mm, 1/8"	30
NO.106	6	10	3mm, 1/8"	30
NO.107	6	10	3mm, 1/8"	30
NO.108	6	10	3mm, 1/8"	30
NO.109	6	10	3mm, 1/8"	30
NO.110	6		3mm, 1/8"	30
NO.111	6		3mm, 1/8"	30
NO.112	3	10	3mm, 1/8"	30

## STCDY072-A, 10PCS HSS MINI ROTARY BURR SET

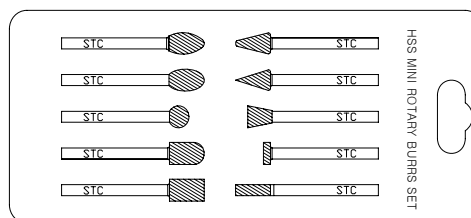

Note: Pls specify 1/8" shank or 3mm shank when ordering.  
Packed in plastic case / blister card.

## STCDY069-2, ROTARY FILES

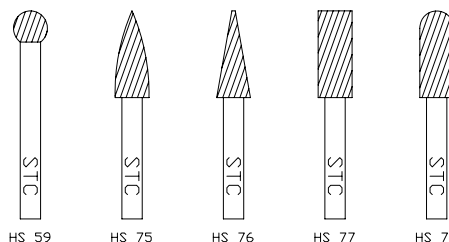

Code No.	Head Diameter	Head Length	Shank Diameter	Shank Length
HS-59	10		6mm, 1/4"	35
HS-75	10	25	6mm, 1/4"	35
HS-76	10	25	6mm, 1/4"	35
HS-77	10	25	6mm, 1/4"	35
HS-78	10	25	6mm, 1/4"	35

Order No.	Pcs/Set	Shank	Description
STCDY067B-1	12	6mm 1/4"	12pcs most popular used carbide burr
STCDY067B-1A	8	1/4"	8pcs carbide burr for general pupose and aluminum
STCDY067B-2	10	1/8", 3mm	10pcs most popular used carbide burr
STCDY067B-2A	10	1/4", 6mm	10pcs most popular used carbide burr
STCDY067B-3	10	1/8", 3mm	10pcs most popular used carbide burr ( solid carbide)
STCDY067B-4	8	1/4", 6mm	8pcs most popular used carbide burr
STCDY067B-5	5	1/8", 3mm	5pcs most popular used carbide burr
STCDY067B-6	5	1/4", 6mm	5pcs most popular used carbide burr
STCDY067B-6	12	1/8", 3mm	12pcs carbide burrs with Tin-coated.

3/32" Shank Carbide Burr also available.

## STCDY069-2, ROTARY FILES

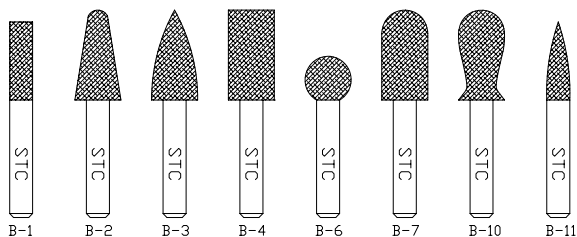

Code No.	Head Diameter	Head Length	Shank Diameter	Shank Length
B-1	6mm	20mm	6mm, 1/4"	30
B-2	12	23	6mm, 1/4"	30
B-3	12	23	6mm, 1/4"	30
B-4	12	23	6mm, 1/4"	30
B-6	12	12	6mm, 1/4"	30
B-7	12	23	6mm, 1/4"	30
B-10	12	20	6mm, 1/4"	30
B-11	6	20	6mm, 1/4"	30

## STCDY072-E, 6PCS/SET HSS ROTARY FILE SET

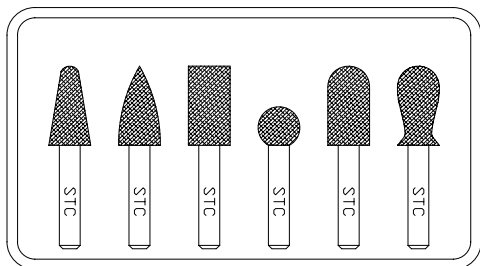

NOTE: Most popular used rotary files in HSS for wood / metal working. With 6mm or 1/4" shank.

## STCDY158, HSS ENLARGING CUTTER

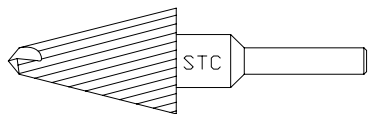

ORDER NO.	CUT SIZE	SHANK
STCDY158-1	0 - 25 mm	8 mm
STCDY158-2	32 - 50 mm	10 mm
STCDY158-3	45 - 60 mm	10 mm

## STCDY070-1, 5PCS ROTARY RASP SET IN POUCH PACKING

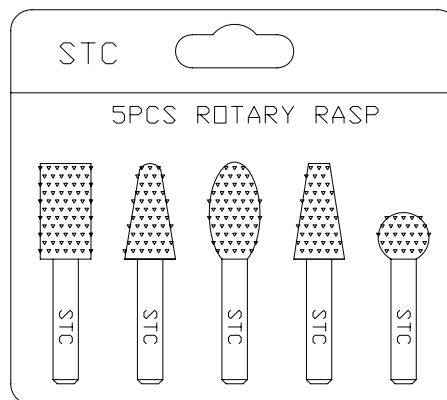

Metric Sizes: 6mm Shank, Inch Sizes: 1/4" Shank.

## STCDY070-2, 6PCS ROTARY RASP SET IN BLISTER CARD

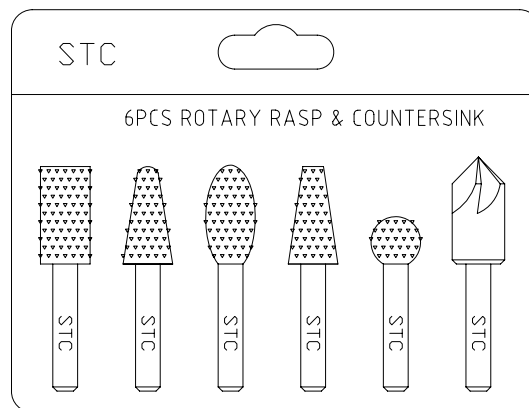

Metric Sizes: 6mm Shank, Inch Sizes: 1/4" Shank.

## STCDY159, DRUM RASP

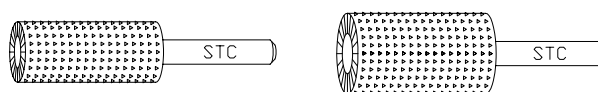

Code No.	Head Diameter	Head Length	Shank Diameter	Overall length	Thickness
D-1	15	36	6	56	3.5
D-2	20	36	6	56	5

## STC511, R8 COLLETS

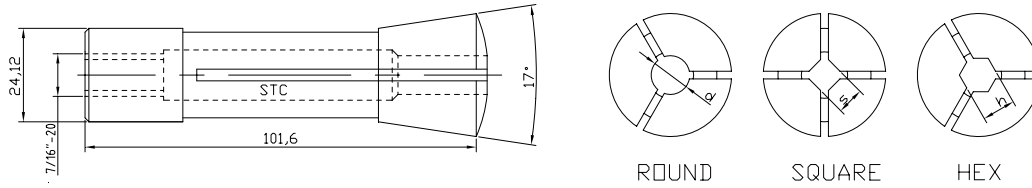

- Material: 65Mn.
- Hardness: Clamping Part HRC55-60, Elastic Part HRC40-45.

ORDER NO.	TYPE	CLAMPING RANGE	weight	High Accuracy	General Accuracy
STC511-R8-01d	Round	1 - 20mm 1/16" - 7/8"	0.24kg	0.0005" 0.013mm	0.001" 0.025mm
STC511-R8-02s	Square	3 - 13 mm 1/8" - 1/2"	0.24kg	0.0005" 0.013mm	0.001" 0.025mm
STC511-R8-03h	Hex	3 - 16mm 1/8" - 5/8"	0.24kg	0.0005" 0.013mm	0.001" 0.025mm

## STC512, 5C COLLETS

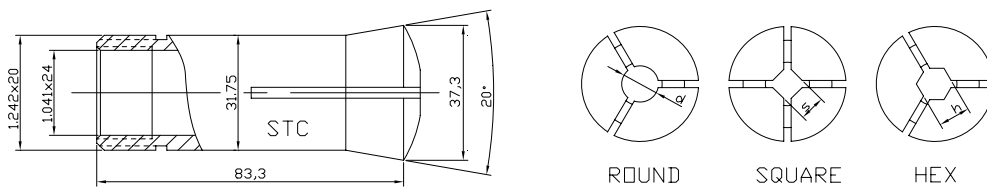

- Material: 65Mn.
- Hardness: Clamping Part HRC55-60, Elastic Part HRC40-45.

ORDER NO.	TYPE	CLAMPING RANGE	Weight	High Accuracy	General Accuracy
STC511-5C-01d	Round	1 - 28mm 1/32" - 1.1/8"	0.24	0.0005" 0.013mm	0.001" 0.025mm
STC511-5C-02s	Square	3 - 19 mm 1/8" - 3/4"	0.24	0.0005" 0.013mm	0.001" 0.025mm
STC511-5C-03h	Hex	3 - 22mm 1/8" - 7/8"	0.24	0.0005" 0.013mm	0.001" 0.025mm

## STC513, MORSE TAPER COLLETS

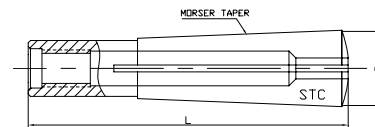

- Material: 65Mn.
- Hardness: Clamping Part HRC55-60, Elastic Part HRC40-45.

ORDER NO.	TAPER	d Hole Diameter	D	L	Weight
JMS1-d	MS1	2 - 8 mm 1/16" - 5/16"	12.2 mm	57 mm	0.05kg
JMS2-d	MS2	2 - 12 mm 1/8" - 1/2"	18.0 mm	68 mm	0.08kg
JMS3-d	MS3	3 - 20 mm 1/8" - 3/4"	24.1 mm	86 mm	0.10kg
JMS4-d	MS4	3 - 25 mm 1/8" - 1"	31.5 mm	108 mm	0.38kg
J7B&S-d	B&S7	2 - 12 mm 1/8" - 1/2"	18.4 mm	79.4 mm	0.096kg
J9B&S-d	B & S9	3 - 20 mm 1/8" - 3/4"	27.08 mm	105 mm	0.32kg

## STC514, DIN6341 COLLETS

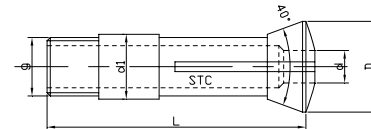

- Material: 65Mn.
- Hardness: Clamping Part HRC55-60, Elastic Part HRC40-45.

ORDER NO.	d1 (mm)	D (mm)	L (mm)	d max (mm)	g	Weight
k8-d	8	12	45	5	M8x0.75	0.06kg
k10-d	10	15	52	6	Tr10 x 1	0.09
k12-d	12	18	60	8	Tr12 x 1	0.11
k16-d	16	24	70	11	Tr16 x 1.5	0.12
k20-d	20	28	80	15	Tr20 x 1.5	0.15
k23-d	23	32	90	18	Tr23 x 1.5	0.21
k28-d	28	38	100	22	Tr28 x 1.5	0.23
k32-d	32	45	110	27	Tr32 x 1.5	0.27
k45-d	45	60	140	36	Tr40 x 2.0	0.32

## STC521, ER COLLETS, DIN6499B

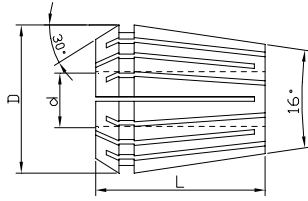

Made of Special Elastic Steel.

Power Clamping Ability. High Accuracy.

TYPE	D (mm)	L	d (mm)	Collapsibility
ER8	8.45	13.5	1.0 - 5.0	0.5 mm
ER11	11.5	18	1.0 - 7.0	0.5 mm
ER16	17	27.5	1.0 - 2.5	0.5 mm
	17	27.5	>2.5 - 10.0	1.0 mm
ER20	21	31.5	1.0 - 2.5	0.5 mm
	21	31.5	>2.5 - 13.0	1.0 mm
ER25	25	34	1.0 - 2.5	0.5 mm
	25	34	>2.5 - 16.0	1.0 mm
ER32	33	40	2.0 - 2.5	0.5 mm
	33	40	>2.5 - 20.0	1.0 mm
ER40	41	46	3.0 - 26.0	1.0 mm
ER50	52	60	6.0 - 10.0	1.0 mm
	52	60	>10.0 - 34.0	2.0 mm

Inch Series

TYPE	D (mm)	L (mm)	d	Collapsibility
ER11	11.5	18	1/32" - 9/32"	0.02"
ER16	17	27.5	1/32" - 3/8"	0.02" - 0.04"
ER20	21	31.5	1/16" - 1/2"	0.02" - 0.04"
ER25	25	34	1/16" - 5/8"	0.02" - 0.04"
ER32	33	40	1/8" - 3/4"	0.02" - 0.04"
ER40	41	46	1/8" - 1"	0.04"

## STC521S, ER COLLET SETS

TYPE	PCS/SET	Description
ER11	12	1.5 - 7.0mm by 0.5mm
	13	1.0 - 7.0mm by 0.5mm
ER16	9	2.0 - 10.0mm by 1mm
	10	1.0 - 10.0mm by 1mm
ER20	12	3.0 - 13.0mm by 1mm
	13	2.0 - 13.0mm by 1mm
ER25	14	3.0 - 16.0mm by 1mm
	15	2.0 - 16.0mm by 1mm
ER32	18	3.0 - 20.0mm by 1mm
	19	2.0 - 20.0mm by 1mm
ER40	21	6.0 - 26.0mm by 1mm
	24	3.0 - 26.0mm by 1mm
ER50	12	12.0 - 34.0mm by 2mm

Inch Sizes

TYPE	Pcs/set	Description
ER11	10	1/32" - 3/8" by 1/32"
ER20	12	1/16", 3/32", 1/8", 3/16", 7/32", 1/4", 5/16", 11/32", 3/8", 13/32", 7/16", 1/2"
ER25	15	1/16", 3/32", 1/8", 3/16", 7/32", 1/4", 5/16", 11/32", 3/8", 13/32", 7/16", 1/2", 17/32", 9/16", 5/8"
ER32	18	3/32", 1/8", 3/16", 7/32", 1/4", 5/16", 11/32", 3/8", 13/32", 7/16", 1/2", 17/32", 9/16", 5/8", 21/32", 11/16", 23/32", 3/4"
ER40	23	1/8", 3/16", 7/32", 1/4", 5/16", 11/32", 3/8", 13/32", 7/16", 1/2", 17/32", 9/16", 5/8", 21/32", 11/16", 23/32", 3/4", 25/32", 13/16", 27/32", 7/8", 15/16", 31/32", 1"

## STC522, EOC COLLETS

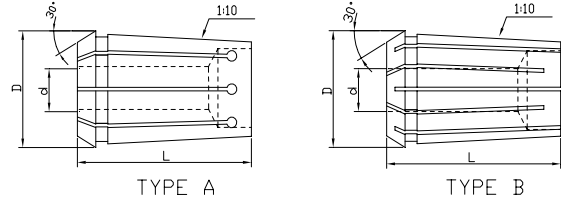

DIN6388A

TYPE	D	L	d
EOC 6A	11.5	21	1 - 6mm
EOC 8A	14.5	26	1 - 8mm
EOC 10A	17.2	30	1 - 10mm
EOC 12A	19.8	34	1 - 12mm
EOC 16A	25.5	40	2 - 16mm
EOC 20A	29.8	45	2 - 20mm
EOC 25A	35.05	52	2 - 25mm
EOC 32A	43.7	60	4 - 32mm
EOC 40A	52.2	68	6 - 40mm
EOC 50A	63.8	80	8 - 50mm

DIN6388B

TYPE	D	L	d
EOC 16B	25.5	40	2 - 16mm
EOC 20B	29.8	45	2 - 20mm
EOC 25B	35.05	52	2 - 25mm
EOC 32B	43.7	60	4 - 32mm
EOC 40B	52.2	68	6 - 40mm
EOC 50B	63.8	80	8 - 50mm

## STC523, TG SINGLE ANGLE COLLETS

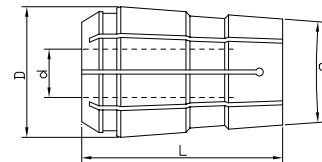

Inch Series

TYPE	D	L	d
TG75	1.063"	1.845"	1/16" - 25/32"
TG100	1.378"	2.381"	1/16" - 1"
TG150	2"	3"	3/32" - 1.9/16"
TG200	2.671"	3.250"	1" - 2"

Metric Series

TYPE	D	L	d
TG75	27mm	46.9mm	1.0 - 20.0mm
TG100	35mm	60.5mm	1.0 - 2.0mm
TG150	50.8mm	76.2mm	2.0 - 40.0mm
TG200	67.8mm	82.55mm	25.0 - 50.0mm

## STC530, ER COLLETS CHUCKS

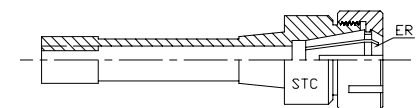

R8 SHANK

TYPE	Shank	ER Type	Drawbar Thread
R8 - ER16	R8	ER16	7/16" - 20
R8 - ER20	R8	ER20	7/16" - 20
R8 - ER25	R8	ER25	7/16" - 20
R8 - ER32	R8	ER32	7/16" - 20
R8 - ER40	R8	ER40	7/16" - 20

## STC530, ER COLLETS CHUCKS

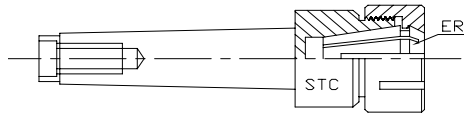

### MORSE TAPER SHANK

TYPE	Shank Type	Collets Type	Drawbar Thread	
			Metric	Inch
MT2 - ER20	MT2	ER20	M10x1.5	3/8"-16
MT2 - ER25	MT2	ER25	M10x1.5	3/8"-16
MT2 - ER32	MT2	ER32	M10x1.5	3/8"-16
MT3 - ER25	MT3	ER25	M12x1.75	1/2"-13
MT3 - ER32	MT3	ER32	M12x1.75	1/2"-13
MT3 - ER40	MT3	ER40	M12x1.75	1/2"-13
MT4 - ER32	MT4	ER32	M16x2.0	5/8"-11
MT4 - ER40	MT4	ER40	M16x2.0	5/8"-11
MT4 - ER50	MT4	ER50	M16x2.0	5/8"-11
MT5 - ER40	MT5	ER40	M20x2.5	3/4"-10
MT5 - ER50	MT5	ER50	M20x2.5	3/4"-10

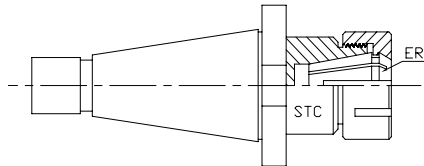

### NT30, NT40, and NT50 TAPER SHANK.

TYPE	Shank Type	Collets Type	Drawbar Thread	
			Metric	Inch
NT30 - ER16	NT30	ER16	M12x1.75	1/2"-13
NT30 - ER20	NT30	ER20	M12x1.75	1/2"-13
NT30 - ER32	NT30	ER25	M12x1.75	1/2"-13
NT30 - ER40	NT30	ER32	M12x1.75	1/2"-13
NT40 - ER16	NT40	ER16	M16x2.0	5/8"-11
NT40 - ER20	NT40	ER20	M16x2.0	5/8"-11
NT40 - ER25	NT40	ER25	M16x2.0	5/8"-11
NT40 - ER32	NT40	ER32	M16x2.0	5/8"-11
NT40 - ER40	NT40	ER40	M16x2.0	5/8"-11
NT40 - ER50	NT40	ER50	M16x2.0	5/8"-11
NT50 - ER32	NT50	ER32	M24x3	1"-8
NT50 - ER40	NT50	ER40	M24x3	1"-8
NT50 - ER50	NT50	ER50	M24x3	1"-8



### STRAIGHT SHANK

Order No.	Shank	ER Type	Shank Length
16 - ER11	16 mm	ER11	50,100, 120, 150mm
16 - ER16	16	ER16	50, 100, 150mm
20 - ER16	20	ER16	50, 100, 150mm
20 - ER20	20	ER20	50, 100, 150, 200mm
20 - ER25	20	ER25	100, 150mm
20 - ER32	20	ER32	50, 100mm
25 - ER25	25	ER25	50, 100,150, 200mm
25 - ER32	25	ER32	50, 100, 150mm
25 - ER40	25	ER40	50mm
32 - ER32	32	ER32	60mm
32 - ER40	32	ER40	50mm

Shank in Inch Sizes also available.

## STC531-S, ER COLLETS CHUCK SET

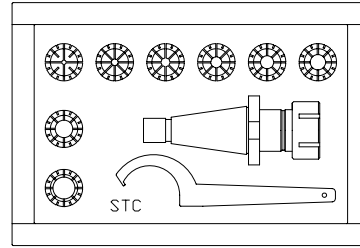

Each set included: 1 collet chuck, 1 spanner & a set of collets.

### ER16-8M

8-pc Collets:  
2, 3, 4, 5, 6, 7, 8, 10mm

Shank		
R8	ISO30	ISO40
ISO50	MT2	MT3
MT4	1/2"	3/4"

### ER16-8IN

8-pc Collets: 3/32, 1/8, 3/16,  
7/32, 1/4, 5/16,11/32, 3/8".

Shank		
R8	ISO30	ISO40
ISO50	MT2	MT3
MT4	1/2"	3/4"

### ER25-6M

6pc Collets:  
4, 6, 8, 10,12, 16mm

Shank		
R8	ISO30	ISO40
ISO50	MT2	MT3
MT4	3/4"	1"

### ER25-6IN

6pc Collets:  
3/16, 1/4, 5/16, 3/8, 1/2, 5/8"

Shank		
R8	ISO30	ISO40
ISO50	MT2	MT3
MT4	3/4"	1"

### ER25-10M

10pc Collets:  
3, 4, 5, 6, 8, 10, 12, 14, 15, 16

Shank		
R8	ISO30	ISO40
ISO50	MT2	MT3
MT4	3/4"	1"

### ER25-10IN

10pc Collets:3/32,1/8,3/16,1/4,  
5/16,3/8,7/16,1/2,9/16,5/8"

Shank		
R8	ISO30	ISO40
ISO50	MT2	MT3
MT4	3/4"	1"

### ER32-6M

6pc Collets:  
6, 8, 10, 12, 16, 20mm.

Shank		
R8	ISO30	ISO40
ISO50	MT3	MT4
MT5	3/4"	1"

### ER32-6IN

6pc Collets:  
1/4, 5/16, 3/8, 1/2, 5/8, 3/4"

Shank		
R8	ISO30	ISO40
ISO50	MT3	MT4
MT5	3/4"	1"

### ER32-12M

12pc Collets:  
3, 4, 5, 6, 8, 10, 12, 14, 15, 16,  
18, 20mm

Shank		
R8	ISO30	ISO40
ISO50	MT3	MT4
MT5	3/4"	1"

### ER32-12IN

12pc Collets:  
1/16, 3/32, 1/8, 3/16, 1/4, 5/16,  
3/8, 7/16, 1/2, 9/16, 5/8, 3/4"

Shank		
R8	ISO30	ISO40
ISO50	MT3	MT4
MT5	3/4"	1"

### ER40-8M

8pc Collets:  
4, 6, 8, 10, 12, 16, 20, 25mm

Shank		
R8	ISO30	ISO40
ISO50	MT3	MT4
MT5	1"	1.1/4"

### ER40-8 IN

8pc Collets:  
1/8,1/4,3/8,1/2,5/8, 3/4,7/8,1"

Shank		
R8	ISO30	ISO40
ISO50	MT3	MT4
MT5	1"	1.1/4"

## ER40-15M

15pc Collets:

4, 5, 6, 8, 10, 12, 14, 15, 16, 18, 20, 22, 24, 25, 26mm

Shank		
R8	ISO30	ISO40
ISO50	MT3	MT4
MT5	1"	1.1/4"

## ER40-15IN

15pc Collets:

1/8, 3/16, 1/4, 5/16, 3/8, 7/16, 1/2, 9/16, 5/8, 11/16, 3/4, 13/16, 7/8, 15/16, 1"

Shank		
R8	ISO30	ISO40
ISO50	MT3	MT4
MT5	1"	1.1/4"

## STC532-S, EOC CHUCK SET

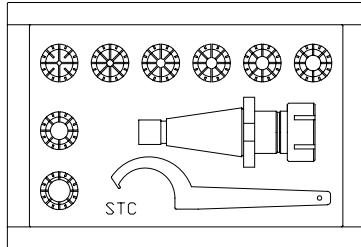

Each set include: 1 collet chuck, a spanner & a set of collets.

## EOC25-7M

8pc Collets:

6, 8, 10, 12, 16, 20, 25mm

Shank		
R8	ISO30	ISO40
ISO50	MT3	MT4
MT5	1"	1.1/4"

## EOC25-7IN

8pc Collets:

1/4", 5/16, 3/8, 1/2, 5/8, 3/4, 1"

Shank		
R8	ISO30	ISO40
ISO50	MT3	MT4
MT5	1"	1.1/4"

## EOC25-8M

8pc Collets:

3, 5, 8, 10, 12, 18, 22, 25mm

Shank		
R8	ISO30	ISO40
ISO50	MT3	MT4
MT5	1"	1.1/4"

## EOC25-8IN

8pc Collets:

1/8, 1/4, 3/8, 1/2, 5/8, 3/4, 7/8, 1"

Shank		
R8	ISO30	ISO40
ISO50	MT3	MT4
MT5	1"	1.1/4"

## EOC25-15M

15pc Collets:

3, 4, 5, 6, 8, 10, 12, 14, 15, 16, 18, 20, 22, 24, 25mm

Shank		
R8	ISO30	ISO40
ISO50	MT3	MT4
MT5	1"	1.1/4"

## EOC25-15IN

15pc Collets:

1/8, 3/16, 1/4, 5/16, 3/8, 7/16, 1/2, 9/16, 5/8, 11/16, 3/4, 13/16, 7/8, 15/16, 1"

Shank		
R8	ISO30	ISO40
ISO50	MT3	MT4
MT5	1"	1.1/4"

## EOC32-8M

8pc Collets:

6, 8, 10, 12, 16, 20, 25, 32mm

Shank		
R8	ISO30	ISO40
ISO50	MT3	MT4
MT5	1"	1.1/4"

## EOC32-8IN

8pc Collets:

1/4, 5/16, 3/8, 1/2, 5/8, 3/4, 1", 1-1/4"

Shank		
R8	ISO30	ISO40
ISO50	MT3	MT4
MT5	1"	1.1/4"

## EOC25-16M

16pc Collets:

5, 6, 7, 8, 9, 10, 11, 12, 13, 14, 15, 16, 18, 20, 25, 32mm

Shank		
R8	ISO30	ISO40
ISO50	MT3	MT4
MT5	1"	1.1/4"

## EOC25-16IN

16pc Collets:

3/16, 1/4, 9/32, 5/16, 3/8, 7/16, 1/2, 9/16, 5/8, 11/16, 3/4, 13/16, 7/8, 15/16, 1", 1-1/4"

Shank		
R8	ISO30	ISO40
ISO50	MT3	MT4
MT5	1"	1.1/4"

## STC541, MORSE TAPER END MILL ADAPTERS WITH DRAWBAR

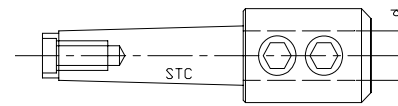

Metric

Shank	Hole Size d (mm)
MS1	4, 6, 8, 10, 12mm
MS2	4, 6, 8, 10, 12, 14, 16, 18, 20mm
MS3	4, 6, 8, 10, 12, 14, 16, 18, 20mm
MS4	4, 6, 8, 10, 12, 14, 16, 18, 20, 22, 25, 32, 40mm
MS5	4, 6, 8, 10, 12, 14, 16, 18, 20, 22, 25, 32, 40, 50, 63mm
MS6	4, 6, 8, 10, 12, 14, 16, 18, 20, 22, 25, 32, 40, 50, 63mm

Inch

Shank	Hole Size d ( inch)
MS1	3/16, 1/4, 5/16, 3/8, 1/2, 5/8, 3/4.
MS2	3/16, 1/4, 5/16, 3/8, 1/2, 5/8, 3/4.
MS3	3/16, 1/4, 5/16, 3/8, 1/2, 5/8, 3/4, 7/8, 1"
MS4	3/16, 1/4, 5/16, 3/8, 1/2, 5/8, 3/4, 7/8, 1", 1-1/4, 1-1/2".
MS5	3/16, 1/4, 5/16, 3/8, 1/2, 5/8, 3/4, 7/8, 1", 1-1/4, 1-1/2, 2", 2-1/2".
MS6	7/8, 1", 1-1/4, 1-1/2, 2", 2-1/2".

## STC542, R8 END MILL ADAPTERS

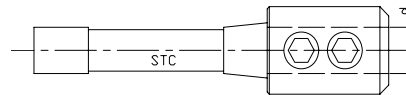

Shank	Hole Size d
R8	4, 5, 6, 7, 8, 9, 10, 12, 14, 16, 18, 20, 22, 25, 27, 32, 40mm.
R8	3/16, 1/4, 5/16, 3/8, 7/16, 9/16, 5/8, 11/16, 3/4, 7/8, 1", 1-1/8, 1-1/4, 1-1/2, 2", 2-1/2"

## STC543, NT END MILL ADAPTERS

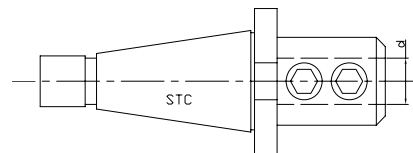

Shank	Hole Size d (mm)
NT30	4, 6, 8, 10, 12, 14, 16, 18, 20, 22, 25, 32mm
NT40	4, 6, 8, 10, 12, 14, 16, 18, 20, 22, 25, 32, 40mm
NT50	4, 6, 8, 10, 12, 14, 16, 18, 20, 22, 25, 32, 40, 50, 63mm

INCH SIZES

Shank	Hole Size d ( inch)
NT30	3/16, 1/4, 5/16, 3/8, 1/2, 5/8, 3/4, 7/8, 1, 1-1/4".
NT40	3/16, 1/4, 5/16, 3/8, 1/2, 5/8, 3/4, 7/8, 1", 1-1/4, 1-1/2, 2", 2-1/2".
NT50	3/16, 1/4, 5/16, 3/8, 1/2, 5/8, 3/4, 7/8, 1", 1-1/4, 1-1/2, 2", 2-1/2".

## STC544, R8 SHELL END MILL ARBORS

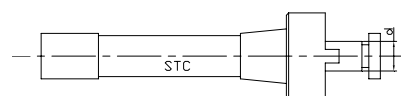

Shank	Arbor Size d
R8	16, 22, 27, 32, 40mm
R8	1/2", 3/4", 7/8", 1", 1-1/4", 1-1/2"

## STC545, STRAIGHT SHANK SHELL END MILL ARBORS

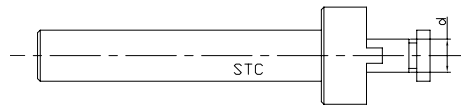

### METRIC SIZES

Shank	Arbor Size d (mm)
12	13, 16, 22mm
16	13, 16, 22, 27mm
20	13, 16, 22, 27, 32, 40mm
25	13, 16, 22, 27, 32, 40, 50mm
32	13, 16, 22, 27, 32, 40, 50, 60mm
40	16, 22, 27, 32, 40, 50, 60mm
50	22, 27, 32, 40, 50, 60mm
63	27, 32, 40, 50, 60mm

### INCH SIZES

Shank	Arbor Size d
1/2"	1/2, 5/8, 3/4, 1", 1-1/4, 1-1/2,
3/4"	3/16, 1/4, 5/16, 3/8, 1/2, 5/8, 3/4.

## STC546, NT END MILL ARBORS

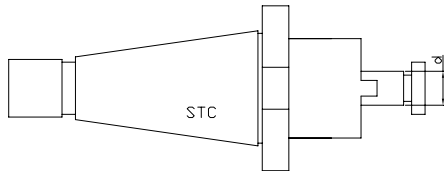

### METRIC SIZES

Shank	Arbor Size d (mm)
NT30	13, 16, 22, 27, 32, 40, 50mm
NT40	16, 22, 27, 32, 40, 50, 60mm
NT50	16, 22, 27, 32, 40, 50, 60mm

### INCH SIZES

Shank	Arbor Size d
NT30	1/2, 5/8, 3/4, 7/8, 1", 1-1/4, 1-1/2, 2"
NT40	1/2, 5/8, 3/4, 7/8, 1", 1-1/4, 1-1/2, 2"
NT50	1/2, 5/8, 3/4, 7/8, 1", 1-1/4, 1-1/2, 2"

## STC547, MORSE TAPER SHELL END MILL ARBORS

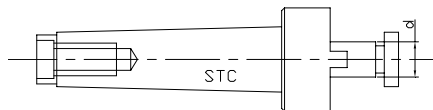

### METRIC SIZES

Shank	Arbor Size d (mm)
MS2	13, 16, 22, 27mm
MS3	13, 16, 22, 27, 32, 40mm
MS4	13, 16, 22, 27, 32, 40, 50mm
MS5	16, 22, 27, 32, 40, 50, 60mm

### INCH SIZES

Shank	Arbor Size d
MS2	1/2, 5/8, 3/4, 7/8".
MS3	1/2, 5/8, 3/4, 7/8, 1", 1-1/4"
MS4	1/2, 5/8, 3/4, 7/8, 1", 1-1/4, 1-1/2"
MS5	1/2, 5/8, 3/4, 7/8, 1", 1-1/4, 1-1/2, 2"

## STC551, BT MILLING CHUCK ARBORS

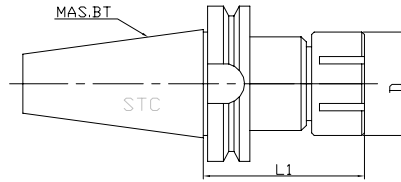

BT x ER x L1	D
BT30 x ER16 x 70	28
BT30 x ER20 x 70	34
BT30 x ER25 x 70	42
BT30 x ER32 x 70	50
BT30 x ER40 x 80	63
BT40 x ER16 x 70	28
BT40 x ER20 x 70	34
BT40 x ER20 x 100	34
BT40 x ER20 x 150	34
BT40 x ER25 x 60	42
BT40 x ER25 x 70	42
BT40 x ER25 x 90	42
BT40 x ER25 x 100	42
BT40 x ER25 x 150	42
BT40 x ER32 x 70	50
BT40 x ER32 x 100	50
BT40 x ER32 x 150	50
BT40 x ER40 x 70	63
BT40 x ER40 x 80	63
BT40 x ER40 x 120	63
BT40 x ER40 x 150	63
BT45 x ER16 x 70	28
BT45 x ER20 x 70	34
BT45 x ER20 x 100	34
BT45 x ER25 x 70	42
BT45 x ER25 x 90	42
BT45 x ER25 x 100	42

BT x ER x L1	D
BT45 x ER32 x 70	50
BT45 x ER32 x 100	50
BT45 x ER32 x 120	50
BT45 x ER40 x 80	63
BT45 x ER40 x 100	63
BT45 x ER40 x 120	63
BT50 x ER16 x 70	34
BT50 x ER16 x 90	34
BT50 x ER16 x 135	34
BT50 x ER20 x 70	42
BT50 x ER20 x 90	42
BT50 x ER20 x 135	42
BT50 x ER20 x 150	42
BT50 x ER20 x 165	42
BT50 x ER25 x 70	50
BT50 x ER25 x 135	50
BT50 x ER25 x 165	50
BT50 x ER32 x 70	63
BT50 x ER32 x 80	63
BT50 x ER32 x 100	63
BT50 x ER32 x 120	63
BT50 x ER40 x 80	28
BT50 x ER40 x 100	34
BT50 x ER40 x 120	34
BT50 x ER40 x 135	42
BT50 x ER50 x 90	42
BT50 x ER50 x 120	42

## STC552, DIN69871.A MILLING CHUCK ARBORS

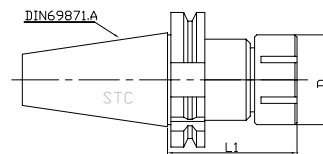

DIN69871.A x ER x L1	D
DIN69871.A30 x ER11x 80	19
DIN69871.A30 x ER16 x 63	28
DIN69871.A30 x ER20 x 63	34
DIN69871.A30 x ER25 x 63	42
DIN69871.A40 x ER11x 80	19
DIN69871.A40 x ER16 x 63	28
DIN69871.A40 x ER16 x 70	28
DIN69871.A40 x ER16 x 100	28
DIN69871.A40 x ER16 x 120	28
DIN69871.A40 x ER20 x 70	34
DIN69871.A40 x ER20 x 100	34
DIN69871.A40 x ER20 x 160	34
DIN69871.A40 x ER25 x 60	42
DIN69871.A40 x ER25 x 70	42

DIN69871.A x ER x L1	D
DIN69871.A40 x ER25 x 100	42
DIN69871.A40 x ER25 x 150	42
DIN69871.A40 x ER32 x 70	50
DIN69871.A40 x ER32 x 80	50
DIN69871.A40 x ER32 x 100	50
DIN69871.A40 x ER32 x 120	50
DIN69871.A40 x ER32 x 150	50
DIN69871.A40 x ER40 x 80	63
DIN69871.A40 x ER40 x 100	63
DIN69871.A40 x ER40 x 120	63
DIN69871.A40 x ER40 x 150	63
DIN69871.A50 x ER16 x 70	28
DIN69871.A50 x ER16 x 100	28
DIN69871.A50 x ER16 x 160	28

## STC552, DIN69871.A MILLING CHUCK ARBORS

DIN69871.A x ER x L1	D	DIN69871.A x ER x L1	D
DIN69871.A50 x ER20x 80	34	DIN69871.A50 x ER32 x 120	50
DIN69871.A50 x ER20 x 63	34	DIN69871.A50 x ER32 x 150	50
DIN69871.A50 x ER20 x 63	34	DIN69871.A50 x ER40 x 80	63
DIN69871.A50 x ER20 x 63	34	DIN69871.A50 x ER40 x 120	63
DIN69871.A50 x ER25 x 70	42	DIN69871.A50 x ER40 x 160	63
DIN69871.A50 x ER25 x 100	42	DIN69871.A50 x ER50 x 90	63
DIN69871.A50 x ER25 x 150	42	DIN69871.A50 x ER50 x 120	78
DIN69871.A50 x ER32 x 80	50	DIN69871.A50 x ER50 x 150	78
DIN69871.A50 x ER32 x 100	50	DIN69871.A50 x ER50 x 200	78

## STC553, CT MILLING CHUCK ARBORS

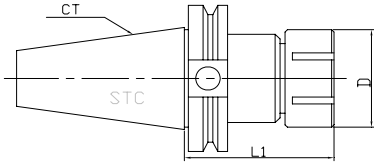

CT x ER x L1	D	CT x ER x L1	D
CT40 x ER16 x 63	28	CT40 x ER50 x 80	78
CT40 x ER16 x 70	28	CT40 x ER50 x 100	78
CT40 x ER16 x 100	28	CT50 x ER16 x 70	28
CT40 x ER16 x 120	28	CT50 x ER16 x 90	28
CT40 x ER16 x 125	28	CT50 x ER16 x 105	28
CT40 x ER16 x 150	28	CT50 x ER16 x 135	28
CT40 x ER20 x 70	34	CT50 x ER20 x 70	34
CT40 x ER20 x 90	34	CT50 x ER20 x 90	34
CT40 x ER20 x 100	34	CT50 x ER20 x 105	34
CT40 x ER20 x 105	34	CT50 x ER20 x 135	34
CT40 x ER20 x 135	34	CT50 x ER20 x 150	34
CT40 x ER20 x 150	34	CT50 x ER20 x 165	34
CT40 x ER25 x 70	42	CT50 x ER25 x 70	42
CT40 x ER25 x 90	42	CT50 x ER25 x 135	42
CT40 x ER25 x 100	42	CT50 x ER25 x 165	42
CT40 x ER25 x 120	42	CT50 x ER25 x 70	42
CT40 x ER25 x 150	42	CT50 x ER32 x 80	50
CT40 x ER32 x 70	50	CT50 x ER32 x 100	50
CT40 x ER32 x 100	50	CT50 x ER32 x 120	50
CT40 x ER32 x 120	50	CT50 x ER32 x 120	50
CT40 x ER32 x 150	50	CT50 x ER40 x 80	63
CT40 x ER40 x 70	63	CT50 x ER40 x 100	63
CT40 x ER40 x 80	63	CT50 x ER40 x 120	63
CT40 x ER40 x 100	63	CT50 x ER40 x 150	63
CT40 x ER40 x 120	63	CT50 x ER50 x 90	78
CT40 x ER40 x 150	63	CT50 x ER50 x 120	78

## STC561, MORSE TAPER DRILL CHUCK ARBORS

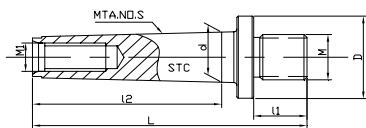

Model	MS.NO.	D	L	M	M1	L2
MS2 - 3/8"-24	MS2	24	88	3/8"-24	M10	13.5
MS2 - 1/2"-20	MS2	27	91	1/2"-20	M10	15.5
MS3 - 3/8"-24	MS3	24	105	3/8"-24	M12	13.5
MS3 - 1/2"-20	MS3	27	108	1/2"-20	M12	15.5

## STC562, MORSE TAPER DRILL CHUCK ARBORS

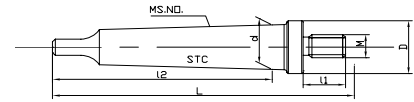

Model	MS.NO	M	D	L
MS1 - 3/8"-24UNF	MS1	3/8"-24	24	83
MS1 - 1/2"-20UNF		1/2"-20	27	85
MS1 - M12 x 1.25		M12x1.25		
MS1 - 5/8"-16UNF		5/8"-16	29	88
MS2 - M10 x 1.0	MS2	M10x1.0	24	97
MS2 - 3/8"-24UNF		3/8"-24		
MS2 - M12 x 1.25		M12x1.25	27	100
MS2 - 1/2"-20UNF		1/2"-20		
MS2 - M16 x 1.5		M16x1.5	29	103
MS2 - 5/8"-16UNF	5/8"-16			
MS2 - 5/8"-20UNF	5/8"-20			
MS3 - M10 x 1.0	MS3	M10x1.0	24	116
MS3 - 3/8"-24UNF		3/8"-24		
MS3 - M12 x 1.25		M12x1.25	27	119
MS3 - 1/2"-20UNF		1/2"-20		
MS3 - M16 x 1.5	M16x1.5	29	122	
MS3 - 5/8"-16UNF	5/8"-16			
MS4 - M12 x 1.25	MS4	M12x1.25	31.6	145

## STC563, MORSE TAPER DRILL CHUCK ARBORS

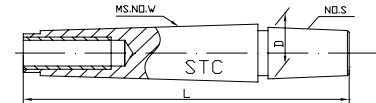

Model	L (mm)	D (mm)	Model	L (mm)	D (mm)
MS1-B10	78	10.094	MS3-B24	145	23.825
MS1-B12	82	12.065	MS3-JT1	105	9.754
MS1-B16	89	15.733	MS3-JT2	111	14.199
MS1-B18	97	17.78	MS3-JT3	120	20.599
MS1-JT0	71	6.35	MS3-JT4	131	28.55
MS1-JT1	76	9.754	MS3-JT5	136	35.89
MS1-JT2	82	14.199	MS3-JT6	114	17.17
MS1-JT3	91	20.599	MS3-JT33	114	15.85
MS1-JT6	85	17.17	MS4-B16	141	15.733
MS1-JT33	85	15.85	MS4-B18	149	17.78
MS2-B10	90	10.094	MS4-B22	158	21.793
MS2-B12	94	12.065	MS4-B24	168	23.825
MS2-B16	101	15.733	MS4-JT2	134	14.199
MS2-B18	109	17.78	MS4-JT3	143	20.599
MS2-B22	117	21.793	MS4-JT4	154	28.55
MS2-JT0	83	6.35	MS4-JT5	159	35.89
MS2-JT1	88	9.754	MS4-JT6	137	17.17
MS2-JT2	94	14.199	MS5-JT33	137	15.85
MS2-JT3	103	20.599	MS5-B16	168	15.733
MS2-JT4	114	28.55	MS5-B18	176	17.78
MS2-JT5	119	35.89	MS5-B22	185	21.793
MS2-JT6	97	17.17	MS5-B24	195	23.825
MS2-JT33	97	15.85	MS5-JT2	161	14.199
MS3-B10	107	10.094	MS5-JT3	170	20.599
MS3-B12	111	12.065	MS5-JT4	181	28.55
MS3-B16	118	15.733	MS5-JT5	186	35.89
MS3-B18	126	17.78	MS5-JT6	164	17.17
MS3-B22	135	21.793	MS5-JT33	164	15.85

## STC564, MORSE TAPER DRILL CHUCK ARBORS

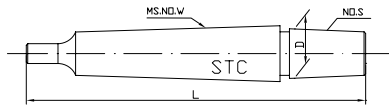

Model	L (mm)	D (mm)
MS1-B10	84	10.094
MS1-B12	88	12.065
MS1-B16	94	15.733
MS1-B18	100	17.78
MS1-JT0	80	6.35
MS1-JT1	85	9.754
MS1-JT2	91	14.199
MS1-JT3	99	20.599
MS1-JT6	94	17.17
MS1-JT33	94	15.85
MS2-B10	97	10.094
MS2-B12	101	12.065
MS2-B16	107	15.733
MS2-B18	115	17.78
MS2-B22	124	21.793
MS2-JT0	93	6.35
MS2-JT1	98	9.754
MS2-JT2	104	14.199
MS2-JT3	112	20.599
MS2-JT4	124	28.55
MS2-JT6	107	17.17
MS2-JT33	107	15.85
MS3-B10	116	6.35
MS3-B12	120	9.754
MS3-B16	126	14.199
MS3-B18	134	20.599
MS3-B22	143	21.793
MS3-B24	153	23.825
MS3-JT0	112	6.35

Model	L (mm)	D (mm)
MS3-JT1	117	9.754
MS3-JT2	123	14.199
MS3-JT3	132	20.599
MS3-JT4	143	28.55
MS3-JT5	148	35.89
MS3-JT6	126	17.17
MS3-JT33	126	15.85
MS4-B12	145	9.754
MS4-B16	151	14.199
MS4-B18	159	20.599
MS4-B22	167	21.793
MS4-B24	177	23.825
MS4-JT2	148	14.199
MS4-JT3	157	20.599
MS4-JT4	168	28.55
MS4-JT5	173	35.89
MS4-JT6	151	17.17
MS4-JT33	151	15.85
MS5-B16	184	14.199
MS5-B18	192	20.599
MS5-B22	200	21.793
MS5-B24	210	23.825
MS5-JT3	190	20.599
MS5-JT4	201	28.55
MS5-JT5	206	35.89
MS5-JT6	184	17.17
MS5-JT33	184	15.85
MS6-JT6	246	17.17

## STC566, 7:24 DRILL CHUCK ARBORS

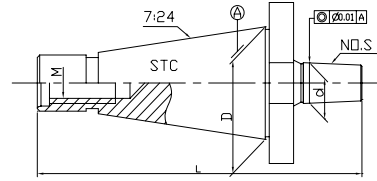

Model	D mm	d mm	L mm	M	Weight kg		
ISO30 - J0	31.75	6.35	99	M12	0.313		
ISO30 - J1		9.754	106		0.326		
ISO30 - J2S		13.94	109		0.341		
ISO30 - J2		14.199	113		0.349		
ISO30 - J33		15.85	122		0.377		
ISO30 - J6		17.17	122		0.388		
ISO30 - J3		20.599	123		0.426		
ISO30 - J4		28.55	136		0.602		
ISO30 - J5		35.89	145		0.827		
ISO40 - J0		44.45	6.35		126	M16	0.789
ISO40 - J1	9.754		133	0.797			
ISO40 - J2S	13.94		136	0.817			
ISO40 - J2	14.199		141	0.829			
ISO40 - J33	15.85		145	0.853			
ISO40 - J6	17.17		145	0.864			
ISO40 - J3	20.599		150	0.902			
ISO40 - J4	28.55		165	1.028			
ISO40 - J5	35.89		170	1.303			
ISO50 - J1	69.85		9.754	175	M24		2.672
ISO50 - J2S		13.94	177	2.692			
ISO50 - J2		14.199	180	2.704			
ISO50 - J33		15.85	184	2.728			
ISO50 - J6		17.17	184	2.739			
ISO50 - J3		20.599	191	2.777			
ISO50 - J4		28.55	202	2.953			
ISO50 - J5		35.89	208	3.178			
ISO30 - B10		31.75	10.094	104		M12	0.325
ISO30 - B12			12.065	108			0.33
ISO30 - B16	15.733		116	0.372			
ISO30 - B18	17.78		124	0.393			
ISO30 - B22	21.793		133	0.46			
ISO30 - B24	23.825		143	0.518			
ISO40 - B10	44.45	10.094	132	M16	0.801		
ISO40 - B12		12.065	136		0.809		
ISO40 - B16		15.733	143		0.848		
ISO40 - B18		17.78	151		0.869		
ISO40 - B22	21.793	160	0.936				
ISO40 - B24	23.825	169	0.994				
ISO50 - B10	69.85	10.094	170	M24	2.684		
ISO50 - B12		12.065	174		2.676		
ISO50 - B16		15.733	182		2.723		
ISO50 - B18		17.78	195		2.744		
ISO50 - B22		21.793	200		2.811		
ISO50 - B24		23.825	215		2.869		

## STC565, R8 DRILL CHUCK ARBORS

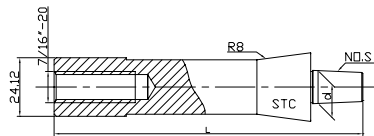

Type	L mm	Weight kg	D mm	NO.S
R8-J0	117	0.393	6.35	J0
R8-J1	122	0.409	9.754	J1
R8-J2S	125	0.4	13.94	J2S
R8-J2	128	0.414	14.199	J2S
R8-J33	132	0.418	15.85	J33
R8-J6	132	0.418	17.17	J6
R8-J3	137	0.465	20.599	J3
R8-J4	148	0.6	28.55	J4
R8-J5	154	0.742	35.89	J5
R8-B6	118.5	0.25	6.35	B6
R8-B10	124	0.386	10.094	B10
R8-B12	128	0.408	12.065	B12
R8-B16	135	0.44	15.733	B16
R8-B18	143	0.454	17.78	B18
R8-B22	152	0.514	21.793	B22
R8-B24	162	0.567	23.825	B24

## STC567, BT DRILL CHUCK ARBORS

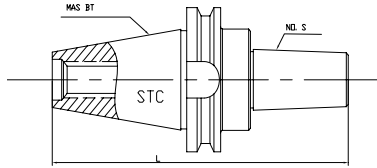

Model MAS.BT to NO.S	L mm
BT30 to JT1-45	110
BT30 to JT2-45	115.6
BT30 to JT2S-45	112.4
BT30 to JT3-45	124.4
BT30 to JT4-45	135.4
BT30 to JT5-45	141
BT30 to JT6-45	118.8
BT30 to JT33-40	113.8
BT30 to JT33-45	118.8
BT30 to B10-45	107.9
BT30 to B12-45	111.9
BT30 to B16-45	117.9
BT30 to B18-45	125.4
BT40 to JT1-45	127.1
BT40 to JT2-45	132.6
BT40 to JT2S-45	129.4
BT40 to JT3-45	141.4
BT40 to JT4-45	152.5
BT40 to JT5-45	158
BT40 to JT6-45	135.8
BT40 to JT33-45	135.8
BT40 to B10-45	124.9
BT40 to B10-120	199.9
BT40 to B12-45	128.9

Model MAS.BT to NO.S	L mm
BT40 to B16-32	121.4
BT40 to B16-45	134.4
BT40 to B16-75	164.4
BT40 to B16-90	179.4
BT40 to B18-45	142.4
BT40 to B18-75	172.4
BT45 to B16-90	196.8
BT45 to B16-100	206.8
BT50 to JT1-45	163.5
BT50 to JT2-45	169
BT50 to JT2S-45	165.9
BT50 to JT3-45	177.8
BT50 to JT4-45	188.9
BT50 to JT5-45	194.4
BT50 to JT6-45	172.2
BT50 to JT33-45	172.2
BT50 to B10-45	161.3
BT50 to B10-100	216.3
BT50 to B12-45	165.3
BT50 to B16-45	170.8
BT50 to B16-60	185.3
BT50 to B16-75	200.8
BT50 to B16-90	215.8
BT50 to B18-45	178.8

## STC569, CAT DRILL CHUCK ARBORS

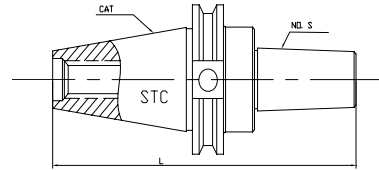

Model	L
CAT40 to JT2-45	135.5
CAT40 to JT3-45	144.2
CAT40 to JT4-45	155.3
CAT40 to JT6-45	138.65
CAT40 to JT33-45	138.65
CAT45 to JT1-45	144.2
CAT45 to JT2-45	150
CAT45 to JT3-45	158.5
CAT45 to JT4-45	196.8
CAT45 to JT5-45	175.2
CAT45 to JT6-45	153
CAT45 to JT33-45	153

Model	L
CAT50 to JT2-45	168.85
CAT50 to JT3-45	177.56
CAT50 to JT4-45	188.67
CAT50 to JT5-45	194.23
CAT50 to JT6-45	172
CAT50 to JT33-45	172
CAT45 to B10-45	142
CAT45 to B12-45	146
CAT45 to B16-32	138.6
CAT45 to B16-45	151.6
CAT45 to B18-32	159.6

## STC571, DIN2185 MORSE TAPER SLEEVES

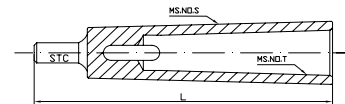

Model MS.NO.S-MS.NO.T	L mm
R51 1 - 0	80
R51 2 - 1	92
R51 3 - 1	99
R51 3 - 2	112
R51 4 - 1	124
R51 4 - 2	124
R51 4 - 3	140
R51 5 - 1	156

Model MS.NO.S-MS.NO.T	L mm
R51 5-2	156
R51 5-3	156
R51 5-4	171
R51 6-1	218
R51 6-2	218
R51 6-3	218
R51 6-4	218
R51 6-5	218

## STC568, DIN69871.A DRILL CHUCK ARBORS

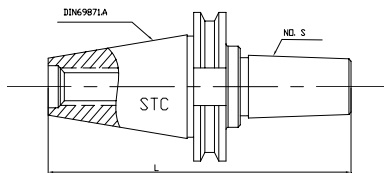

Model	Total Length
DIN69871.A40 to J0-32	111.5
DIN69871.A40 to J1-32	117
DIN69871.A40 to J2-32	122.6
DIN69871.A40 to J2S-32	119.5
DIN69871.A40 to J3-32	131.4
DIN69871.A40 to J4-32	142.5
DIN69871.A40 to J5-32	148
DIN69871.A40 to J6-32	125.8
DIN69871.A40 to J33-32	125.8
DIN69871.A40 to B6-32	110.4
DIN69871.A40 to B10-32	114.9
DIN69871.A40 to B10-45	127.9
DIN69871.A40 to B12-32	118.9
DIN69871.A40 to B12-45	166.9
DIN69871.A40 to B16-26	118.4

## STC572, DIN2187 EXTENSION SOCKET

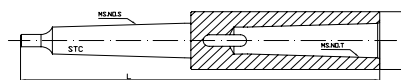

Model	L
R52 1-1	145
R52 1-2	160
R52 1-3	181
R52 2-1	160
R52 2-2	175
R52 2-3	196
R52 2-4	221
R52 3-1	175
R52 3-2	194
R52 3-3	215
R52 3-3A	215
R52 3-4	240
R52 3-5	275
R52 4-1	200
R52 4-2	215

Model	L
R52 4-3	240
R52 4-4	265
R52 4-5	300
R52 4-6	368
R52 5-1	232
R52 5-2	247
R52 5-3	268
R52 5-4	300
R52 5-5	335
R52 5-6	403
R52 6-1	294
R52 6-2	309
R52 6-3	330
R52 6-4	355
R52 6-5	390

## STC573, 273 MORSE CENTER SLEEVES

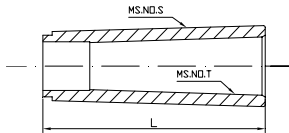

Model MS.NO.S-MS.NO.T	L mm
R54 2 x 1	45
R54 3 x 1	55
R54 3 x 2	65
R54 4 x 2	70
R54 4 x 3	75

Model MS.NO.S-MS.NO.T	L mm
R54 5 x 3	80
R54 5 x 4	100
R54 6 x 4	105
R54 6 x 5	120

## STC574, MORSE TAPER SLEEVE

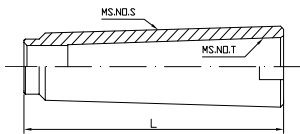

Model MS.NO.S-MS.NO.T	L mm
R43 2-1	74
R43 3-1	80
R43 3-2	80
R43 4-1	90
R43 4-2	90
R43 4-3	90

Model MS.NO.S-MS.NO.T	L mm
R43 5-2	110
R43 5-3	110
R43 5-4	110
R43 6-3	130
R43 6-4	130
R43 6-5	130

## STC575, R8 to MS SLEEVES

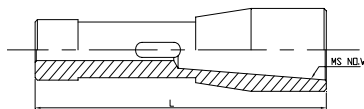

Model R8 - MS.NO.W	L mm
BR8 - 1W	102
BR8 - 2W	105
BR8 - 3W	135
BR8 - 4W	218

Model R8 - MS.NO.	L mm
BR8 - 1	114
BR8 - 2	127
BR8 - 3	153
BR8 - 4	240

## STC576W, BT to MT ADAPTOR WITH DRAWBAR

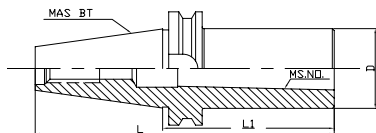

Model BT- NO.S-L1	L mm
BT40 - MT1W-45	110.4
BT40 - MT2W-60	125.4
BT40 - MT3W-75	140.4
BT40 - MT3W-90	155.4
BT40 - MT4W-95	160.4
BT40 - MT4W-100	165.4
BT50 - MT1W-45	146.8
BT50 - MT2W-45	146.8

Model BT- NO.S-L1	L mm
BT50 - MT2W-60	161.8
BT50 - MT3W-60	161.8
BT50 - MT3W-75	176.8
BT50 - MT4W-80	181.8
BT50 - MT4W-100	201.8
BT50 - MT5W-100	201.8
BT50 - MT4W-120	221.8

## STC576, BT to MT ADAPTOR WITH TANG

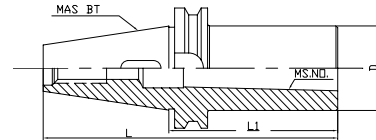

Model BT- NO.S-L1	L mm
BT30 - MT1-45	93.5
BT30 - MT1-50	98.4
BT30 - MT2-60	108.4
BT30 - MT3-80	128.4
BT40 - MT1-45	110.4
BT40 - MT1-50	115.4
BT40 - MT1-120	185.4
BT40 - MT2-50	115.4
BT40 - MT2-60	125.4
BT40 - MT2-120	185.4
BT40 - MT3-70	135.4
BT40 - MT3-75	140.4
BT40 - MT4-90	155.4
BT40 - MT4-95	160.4
BT40 - MT4-135	200.4
BT40 - MT4-165	230.4
BT45 - MT1-120	202.8
BT45 - MT2-120	202.8

Model BT- NO.S-L1	L mm
BT45 - MT3-120	202.8
BT45 - MT3-140	222.8
BT45 - MT4-98	180.8
BT50 - MT1-45	146.8
BT50 - MT2-50	151.8
BT50 - MT2-60	161.8
BT50 - MT2-120	221.8
BT50 - MT2-135	236.8
BT50 - MT3-65	166.8
BT50 - MT3-75	176.8
BT50 - MT3-120	221.8
BT50 - MT3-135	236.8
BT50 - MT3-150	251.8
BT50 - MT4-85	186.8
BT50 - MT4-95	196.8
BT50 - MT4-180	281.8
BT50 - MT5-105	206.8
BT50 - MT5-108	209.8

## STC577W, CT to MT ADAPTOR WITH DRAWBAR

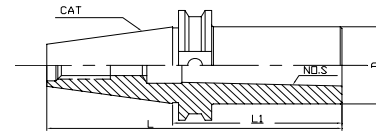

Model CT- NO.S-L1	L mm
CT40 - MT1W-45	113.25
CT40 - MT2W-60	128.25
CT40 - MT3W-75	143.25
CT40 - MT3W-90	158.25
CT40 - MT4W-100	168.25

Model CT- NO.S-L1	L mm
CT40 - MT4W-120	168.25
CT50 - MT2W-60	161.6
CT50 - MT3W-60	161.6
CT50 - MT4W-90	191.6
CT50 - MT5W-100	201.6

## STC577, CT to MT ADAPTOR WITH TANG

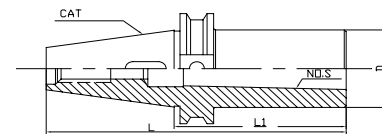

Model CT- NO.S-L1	L mm
CT40 - MT1-45	113.25
CT40 - MT2-63	131.25
CT40 - MT3-75	143.25
CT40 - MT4-100	168.25
CT45 - MT1-40	122.25
CT45 - MT2-50	132.25
CT45 - MT3-73	155.25
CT45 - MT4-95	177.25
CT45 - MT4-125	207.25

Model CT- NO.S-L1	L mm
CT50 - MT1-40	141.6
CT50 - MT2-50	151.6
CT50 - MT2-135	236.6
CT50 - MT3-63	164.6
CT50 - MT3-150	251.6
CT50 - MT4-65	166.6
CT50 - MT4-85	186.6
CT50 - MT5-105	206.6

## STC581-D11, DEAD CENTER.

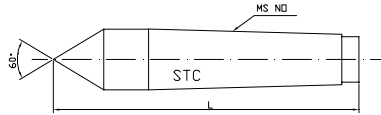

Model	MS.NO	L	Accuracy
D111	1	80	0.01
D112	2	100	0.01
D113	3	125	0.01

Model	MS.NO	L	Accuracy
D114	4	160	0.01
D115	5	200	0.01
D116	6	280	0.01

## STC581-D12, CARBIDE DEAD CENTER

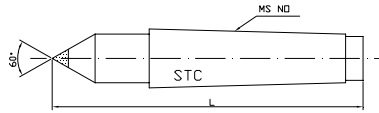

Model	MS.NO	L	Accuracy
D121	1	80	0.01
D122	2	100	0.01
D123	3	125	0.01

Model	MS.NO	L	Accuracy
D124	4	160	0.01
D125	5	200	0.01
D126	6	280	0.01

## STC581-D13, HALF NOTCHED CENTER

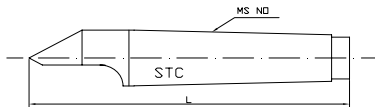

Model	MS.NO	L	Accuracy
D131	1	80	0.01
D132	2	100	0.01
D133	3	125	0.01

Model	MS.NO	L	Accuracy
D134	4	160	0.01
D135	5	200	0.01
D136	6	280	0.01

## STC581-D14, HALF NOTCHED CARBIDE CENTER

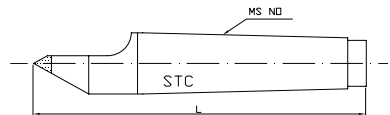

Model	MS.NO	L	Accuracy
D141	1	60	0.01
D142	2	100	0.01
D143	3	125	0.01

Model	MS.NO	L	Accuracy
D144	4	160	0.01
D145	5	200	0.01
D146	6	280	0.01

## STC582-DL, EXTENDED LIVE CENTER

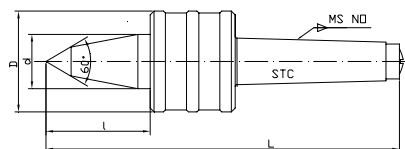

Model	I	L	Accuracy	D	d	MS.NO.
DL412	28.5	141	0.01	40	18	2
DL413	36.5	168	0.01	45	22	3
DL414	36.5	190	0.01	45	22	4
DL415	62	267.5	0.015	78	40	5
DL416	75	346.5	0.015	102	50	6

## STC581-D42, BULL NOSE CENTER

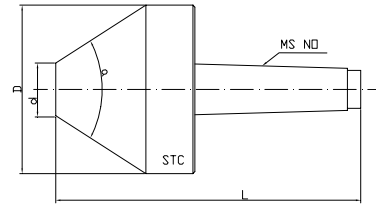

Model	MS.NO	d (mm)	L (mm)	$\alpha$	D (mm)
D422x85	2	12	126	75°	85
D422x60	2	20	137	60°	60
D422x70	2	20	137	60°	70
D423x80	3	25	166	60°	80
D423x90	3	32	169	60°	90
D423x100	3	30	160	75°	100
D424x100	4	32	206	60°	100
D424x110	4	35	184	75°	110
D424x160	4	12	210	75°	160
D424x80	4	32	167	75°	80
D425x200	4	40	225	75°	200
D425x80	5	12	199	75°	80
D425x100	5	32	206	75°	100
D425x120	5	40	251	75°	120
D425x200	5	40	252	60°	200
D425x250	5	56	281	75°	250
D426x250	6	56	335	75°	250

## STC582-DA, PRECISION LIGHT-DUTY LIVE CENTER

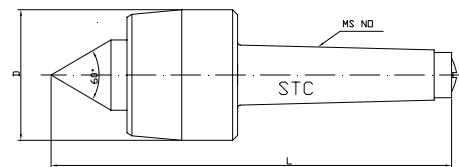

Model	MS.NO	D	L	Accuracy
DA312	2	45	135	0.005
DA313	3	60	167	0.006
DA314	4	69	195	0.006
DA315	5	90	253	0.006

## STC582-DH, LIVE CENTER

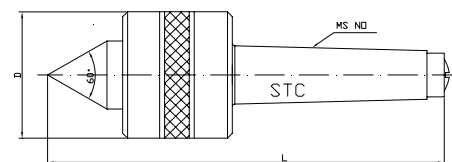

Model	MS.NO	D	L	Accuracy
DH2	2	45	135	0.01
DH3	3	60	167	0.01
DH4	4	69	195	0.01
DH5	5	78	244	0.01
DH6	6	110	358	0.015

## STC582-D4, MEDIUM-DUTY LIVE CENTER

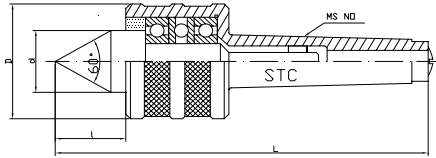

Model	MS.NO	D	L	Accuracy
D412	2	42	136	0.01
D413	3	58	168	0.01
D414	4	69	195	0.01
D415	5	90	253	0.015
D416	6	107	254	0.015

## STC582-D4, HEAVY-DUTY LIVE CENTER

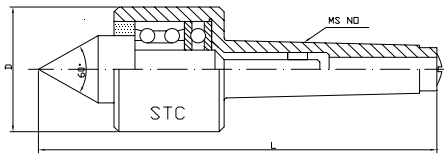

Model	MS.NO	D	L	Accuracy
DM511	MS1	38	109.6	0.008
DM512	MS2	48	128.5	0.01
DM513	MS3	58	156	0.01
DM514	MS4	68	192.5	0.01
DM515	MS5	90	245	0.012
DM516	MS6	130	342.5	0.015

## STC585, KEY TYPE DRILL CHUCK

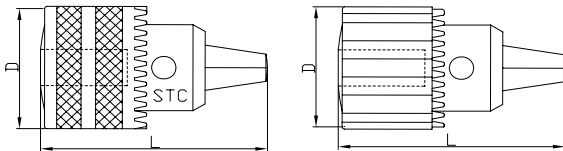

Model	Capacity		Mount	D mm	L mm
	mm	Inch			
J2506	0.6 - 6	1/64" - 1/4"	B10	30.3	49
J2510	1.5 - 10	1/16" - 3/8"	B12	34	58.5
J2513	1.5 - 13	1/16" - 1/2"	B16	42	71.5
J2516	3.0 - 16	1/8" - 5/8"	B16	52	86
J2516B	1.0 - 16	1/8" - 5/8"	B18	52	86
J2608	0.6 - 6	1/64" - 1/4"	JT11	30.3	49
J2610	1.5 - 10	1/16" - 3/8"	JT2	34	58.5
J2613	1.5 - 13	1/16" - 1/2"	JT33	42	71.5
J3506	0.6 - 6	1/64" - 1/4"	3/8"-24	30.3	49
J3510	1.5 - 10	1/16" - 3/8"	3/8"-24	34	58.5
J3510	1.5 - 10	1/16" - 3/8"	1/2"-20	34	58.5
J3510	1.5 - 10	1/16" - 3/8"	M10x1.0	34	58.5
J3510	1.5 - 10	1/16" - 3/8"	M12x1.25	34	58.5
J3513	1.5 - 13	1/16" - 1/2"	3/8"-24	42	71.5
J3513	1.5 - 13	1/16" - 1/2"	1/2"-20	42	71.5
J3513	1.5 - 13	1/16" - 1/2"	M12x1.0	42	71.5
J3513	1.5 - 13	1/16" - 1/2"	M12x1.25	42	71.5
J3513	1.5 - 13	1/16" - 1/2"	M14x1.0	42	71.5
J3516	3.0 - 16	1/8" - 5/8"	3/8"-24	52	86
J3516	3.0 - 16	1/8" - 5/8"	1/2"-20	52	86
J3516	3.0 - 16	1/8" - 5/8"	5/8"-16	52	86
J3516	3.0 - 16	1/8" - 5/8"	M12x1.25	52	86

## STC585A, KEYLESS DRILL CHUCK

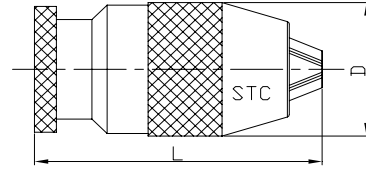

Model	Capacity		Mount	D mm	L mm
	mm	Inch			
J0106	0,5 - 6,0		B10	34	72
J0206		1/64"-1/4"	JT1		
J0108	0,5 - 8,0		B12	42	82
J0208		1/64"-5/16"	JT12		
J0110	1,0 - 10,0		B12	44	88
J0210		1/32"-3/8"	JT2		
J0210A			JT33	44	97
J0113	1,0 - 13,0		B16		
J0113A				49	100
J0213		1/32"-1/2"	JT33		
J0213A			JT6	54	110
J0116A	3,0 - 16,0		B16		
J0116			B18	60	125
J0216		1/8"-5/8"	JT6		
J0216A			JT3	60	125
J0120	5,0 - 20,0		B22		
J0220		3/16"-3/4"	JT3	34	64
J0306	0,5 - 6,0		M10x1		
J0306A		1/64"-1/4"	3/8"-24	40	80
J0308	0,5 - 8,0		M10x1		
J0308A		1/64"-5/16"	3/8"-24	42	86
J0308B	0,5 - 8,0		M12x1.25		
J0308C		1/64"-5/16"	1/2"-20	44	97
J310	1,0 - 10,0		M10x1		
J310A		1/32"-3/8"	3/8"-24	48	107
J310B	1,0 - 10,0		M12x1.25		
J310C		1/32"-3/8"	1/2"-20	44	97
J0313	1,0 - 13,0		M10x1		
J0313A		1/32"-1/2"	3/8"-24	44	97
J0313B	1,0 - 13,0		M12x1.25		
J0313C		1/32"-1/2"	1/2"-20	48	107
J0316	3,0 - 16,0		M12x1.25		
J0316A		1/8"-5/8"	1/2"-20	48	107
J0316B	3,0 - 16,0		M16x1.5		
J0316C		1/8"-5/8"	5/8"-16		

## STC516, J41 TAP CHUCK

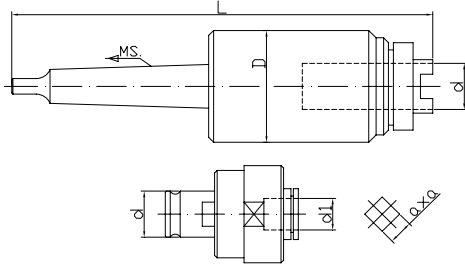

This device is consisted of a tap chuck & tap collets.  
The chuck has compensating device for thread pitch.  
Collect chuck has overload torque protection device.

Model	MS.	Tap Range	D	d	L
J4112-MS2	MS2	M3-M12	46	19	171.5
J4112-MS3	MS3				191
J4112-MS4	MS4				216
J4116-R8	R8	M3-M16			193.6
J4116-MS2	MS2				171.5
J4116-MS3	MS3				191
J4116-MS4	MS4	216			
J4124-MS3	MS3	M12-M24	66	30	227
J4124-MS4	MS4				252
J4124-MS5	MS5				284

## STC517-A, J45 TAP COLLETS

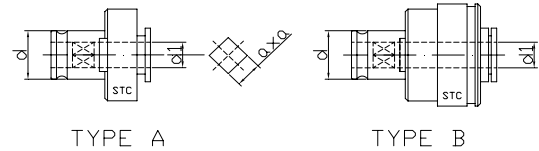

Model d1 x a	d (mm)	DIN371	DIN374	DIN376	
3.5 x 2.7	19	M3	M5	M5	
4 x 3		M3.5			
4.5 x 3.4		M4	M6		
6 x 4.9		M5, M6	M8	M8	
7 x 5.5			M10	M10	
8 x 6.2		M8			
9 x 7			M12	M12	
10 x 8		31	M10		
11 x 9				M14	M14
12 x 9				M16	M16
14 x 11			M18	M18	
16 x 12			M20	M20	
18 x 14.5	48			M22, M24	M22, M24
20 x 16			M27	M27	
22 x 18			M30	M30	
25 x 20			M33	M33	
28 x 22			M36	M36	

## STC517, J45 TAP CHUCK

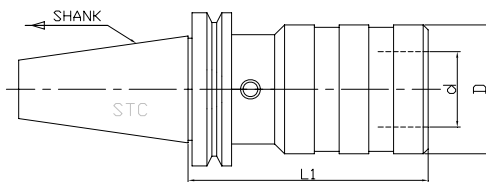

This unit is consisted of chuck and tap collet  
The chuck has installed compensating device for thread pitch.

Model	Shank	Tap Range	D	d	L1
A30 - 12	DIN69871.A30	M3-M12	36	19	59
A40 - 12	DIN69871.A40				62
A50 - 12	DIN69871.A50				59
BT30 - 12	BT30				64
BT50 - 12	BT50				75
A30 - 20	DIN69871.A30	M7-M20	53	31	97
A40 - 20	DIN69871.A40				
A50 - 20	DIN69871.A50				
BT30 - 20	BT30				
BT50 - 20	BT50				
A30 - 36	DIN69871.A30	M14-M36	78	48	149
A40 - 36	DIN69871.A40				
A50 - 36	DIN69871.A50				
BT30 - 36	BT30				
BT50 - 36	BT50				

## STC518, J52 TAP CHUCK

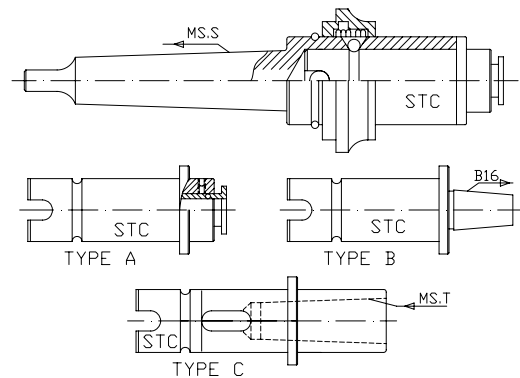

This unit consists of chuck shank and three adaptors ( drill chuck adaptor, Morse Taper Adaptor and Tap Adaptor).

Model	D mm	d mm	MS,S	Tap Range	MS.T
J5212-MS3	57	25	MS3	M3-M16	MS2
J5216-MS4			MS4		MS2
J5216-MS5			MS5		MS2
J5224-MS4	82	40	MS4	M8-M24	MS2,MS3
J5224-MS5			MS5		MS2,MS3

## STC519, J46 REVERSIBLE TAPPING CHUCK

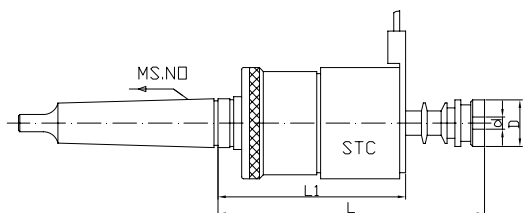

Model	Tapping Range	d	D	L	MS.NO
		mm	mm	mm	
J467	M2-M7	2,5-6,5	23	135	MS1-JT33
					MS3-JT33
J4612	M5-M12	3,5-10	28	164	MS3-M16
					MS4-M16
J4620	M8-M20	6,3-14	38	205	MS3-M16
					MS4-M16

## STC593, ZXQGG PRECISION SINE TOOL VISE

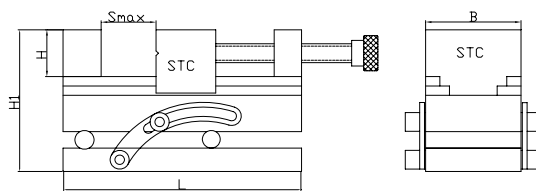

Model	B	H	S max	L	H1
ZXQGG 50	50	25	60	140	86.6
ZXQGG 63	63	32	85	175	94.6
ZXQGG 73	73	35	90	190	111
ZXQGG 80	80	40	95	200	121
ZXQGG 88	88	40	120	235	125
ZXQGG 100	100	45	125	245	139.2
ZXQGG 125	125	50	160	285	154.2
ZXQGG 150	150	50	190	330	160.9

Angle adjust rang: 0 - 45°.

## STC591, QGG PRECISION TOOL VISE

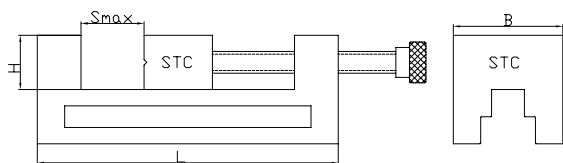

Model	B (mm)	H (mm)	S max	L (mm)	WT(kg)
QGG 50	50	25	65	155	3.2
QGG 60	60	25	55	110	2.4
QGG 63	63	32	85	190	3.8
QGG 73	73	35	100	210	5.0
QGG 80	80	40	100	220	6.5
QGG 88	88	40	125	250	11.0
QGG 100	100	45	125	260	13.0
QGG 125	125	50	160	300	19.5
QGG 125A	125	50	210	350	23.0
GQQ 150	150	50	175	315	23.8

## STC595, CHM UNIVERSAL VISE

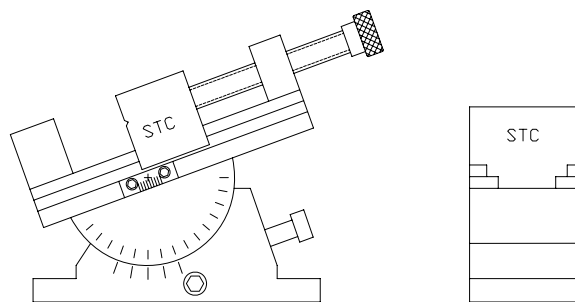

Model	Jaw Width	Jaw Depth	Max Opening	Dimension L x W x L mm
CHM80	70	30	85	195 x 110 x 137
CH120	120	40	155	400 x 180 x 210

## STC592, QKG PRECISION TOOL VISE

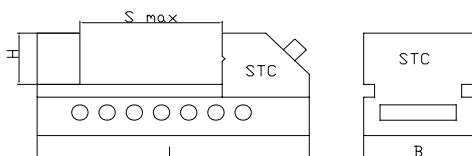

Model	B (mm)	H (mm)	S max	L (mm)	WT(kg)
QKG 25	26	9.15	22	65.4	0.5
QKG 36	36	20	40	100	1.2
QKG 38	38	20	44	105	1.3
QKG 50	50	25	65	140	2.0
QKG 63	63	32	85	175	3.0
QKG 73	73	35	100	190	4.1
QKG 80	80	40	100	200	5.5
QKG 88	88	40	125	235	7.3
QKG 100	100	45	125	245	10.0
QKG 125	125	50	160	285	18.0
QKG 150	150	50	200	330	21.5
QKG 150A	150	50	250	380	23.0
QKG 150B	150	50	300	430	24.0

## STC601, K11 SERIES THREE-JAWS SELF CENTER CHUCKS

K11 Series Three-jaw Self Centering Chuck is subdivided into three types: K11, K11A and K11C. Type K11 provides two set of clutches in different directions which can be used respectively. Type K11A provides ISO3442 standard clutches. Soft Clutches are to be provided on request. Higher centering accuracy can be achieved after being rubbed on the machine, so as to satisfy the need for holding.

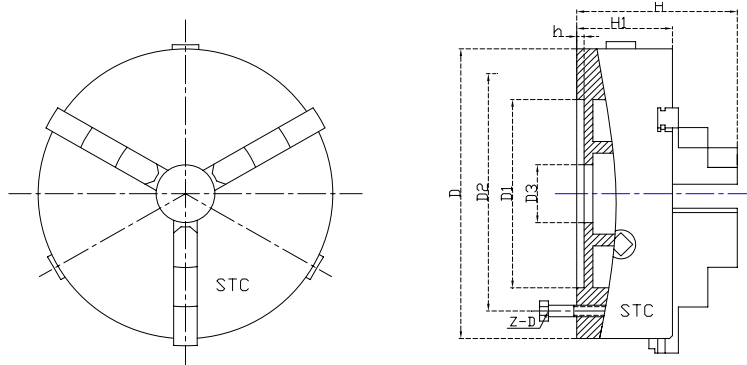

Model	D mm	D1 mm	D2 mm	D3 mm	H mm	H1 mm	h mm	Z-D
K1180	80	55	66	16	66	50	3.5	3-M6
K11100	100	72	84	22	74.5	55	3.5	3-M8
K11125	125	95	108	30	84	58	4	3-M8
K11130	130	100	115	30	86	60	3.5	3-M8
K11160	160	130	142	40	95	65	5	3-M8
K11160A	160	130	142	40	109	65	5	3-M8
K11165	165	130	145	40	96.5	66.5	4.5	3-M8
K11165A	165	130	145	40	110.5	66.5	4.5	3-M8
K11200	200	165	180	65	109	75	5	3-M10
K11200A	200	165	180	65	122	75	5	3-M10
K11200C	200	165	180	65	122	75	5	3-M10
K11240	240	195	215	70	120	80	8	3-M12
K11240A	240	195	215	70	136	80	8	3-M12
K11240C	240	195	215	70	130	80	8	3-M12
K11250	250	206	226	80	120	80	5	3-M12
K11250A	250	206	226	80	136	80	5	3-M12
K11250C	250	206	226	80	130	80	5	3-M12
K11315	315	260	285	100	142.5	90	6	3-M16
K11315A	315	260	285	100	155.5	90	6	3-M16
K11315C	315	260	285	100	155.5	90	6	3-M16
K11320	320	270	290	100	142.5	90	6	3-M16
K11320A	320	270	290	100	155.5	90	6	3-M16
K11320C	320	270	290	100	155.5	90	6	3-M16
K11325	325	272	296	100	142.5	90	6	3-M16
K11325A	325	272	296	100	155.5	90	6	3-M16
K11325C	325	272	296	100	155.5	90	6	3-M16
K11380	380	325	350	130	155.5	100	6	3-M16
K11380A	380	325	350	130	171.5	100	6	3-M16
K11380C	380	325	350	130	164.5	100	6	3-M16
K11400	400	340	368	130	155.5	100	6	3-M16
K11400A	400	340	368	130	171.5	100	6	3-M16
K11400C	400	340	368	130	164.5	100	6	3-M16
K11500	500	440	465	200	181	115	6	6-M16
K11500A	500	440	465	200	203	115	6	6-M16
K11630	630	560	595	260	194	130	7	6-M16
K11630A	630	560	595	260	218	130	7	6-M16
K11800A	800	710	760	385	242	149	8	6-M20

## STC602, K12 SERIES FOUR-JAWS SELF CENTER CHUCKS

K12 series Four-jaw Self Center Chuck is suitable for lot production of square, eight-square type accessories, and is self centering. Type K12 provides two sets of clutches in different directions which can be used respectively. Type K12A provides ISO3442 standard clutches. and Type K12C provides traditional separate clutches.

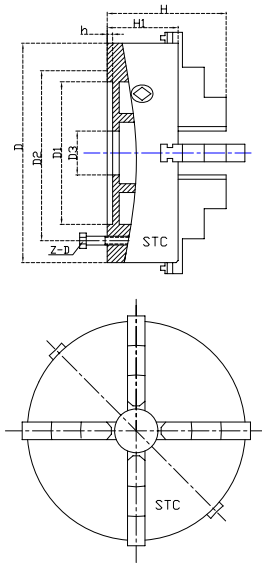

Model	D mm	D1 mm	D2 mm	D3 mm	H mm	H1 mm	h mm	Z-D
K12125	125	95	108	30	84	58	4	3-M8
K12130	130	100	115	30	86	60	3.5	3-M8
K12160	160	130	142	40	95	65	5	3-M8
K12160A	160	130	142	40	109	65	5	3-M8
K12165	165	130	145	40	96.5	66.5	4.5	3-M8
K12165A	165	130	145	40	110.5	66.5	4.5	3-M8
K12200	200	165	180	65	109	75	5	3-M10
K12200A	200	165	180	65	122	75	5	3-M10
K12200C	200	165	180	65	122	75	5	3-M10
K12250	250	206	226	80	120	80	5	3-M12
K12250A	250	206	226	80	136	80	5	3-M12
K12250C	250	206	226	80	130	80	5	3-M12
K12315	315	260	285	100	142.5	90	6	3-M16
K12315A	315	260	285	100	155.5	90	6	3-M16
K12315C	315	260	285	100	155.5	90	6	3-M16
K12320	320	270	290	100	142.5	90	6	3-M16
K12320A	320	270	290	100	155.5	90	6	3-M16
K12320C	320	270	290	100	155.5	90	6	3-M16
K12325	325	272	296	100	142.5	90	6	3-M16
K12325A	325	272	296	100	155.5	90	6	3-M16
K12325C	325	272	296	100	155.5	90	6	3-M16
K12380	380	325	350	130	155.5	100	6	3-M16
K12380A	380	325	350	130	171.5	100	6	3-M16
K12380C	380	325	350	130	164.5	100	6	3-M16
K12400	400	340	368	130	155.5	100	6	3-M16
K12400A	400	340	368	130	171.5	100	6	3-M16
K12400C	400	340	368	130	164.5	100	6	3-M16
K12500	500	440	465	200	181	115	6	6-M16
K12500A	500	440	465	200	203	115	6	6-M16
K12630	630	560	595	260	194	130	7	6-M16
K12630A	630	560	595	260	218	130	7	6-M16

## STC603, K72 SERIES FOUR-JAWS INDEPENDENT CHUCKS

K72 series Four-jaw Independent Chuck adopts short cylinder and short circular cone shape. Short circular cone shape can be subdivided into two types according to the way of joining with the rod of machine tool.

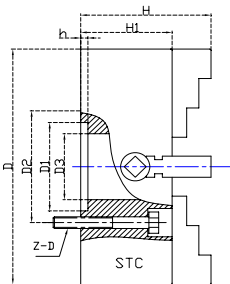

Model	D mm	D1 mm	D2 mm	D3 mm	H mm	H1 mm	h mm	Z-D
K72160	160	65	95	45	93	65	5	4-M10
K72200	200	75	95	65	107	75	6	4-M10
K72250	250	110	130	75	120	80	6	4-M12
K72315	315	140	165	95	138	90	6	4-M16
K72320	320	140	165	95	138	90	6	4-M16
K72350	350	130	168	95	138	90	6	4-M16
	350	140	168	95	138	90	6	4-M16
K72400	400	160	185	125	143	95	8	4-M16
K72500	500	200	236	160	160	105	8	4-M20
K72520	520	260	300	205	160	105	10	4-M16
K72630	630	220	258	180	180	118	10	4-M20
K72800	800	250	300	210	202	132	12	8-M20